

# MODEL RANGE

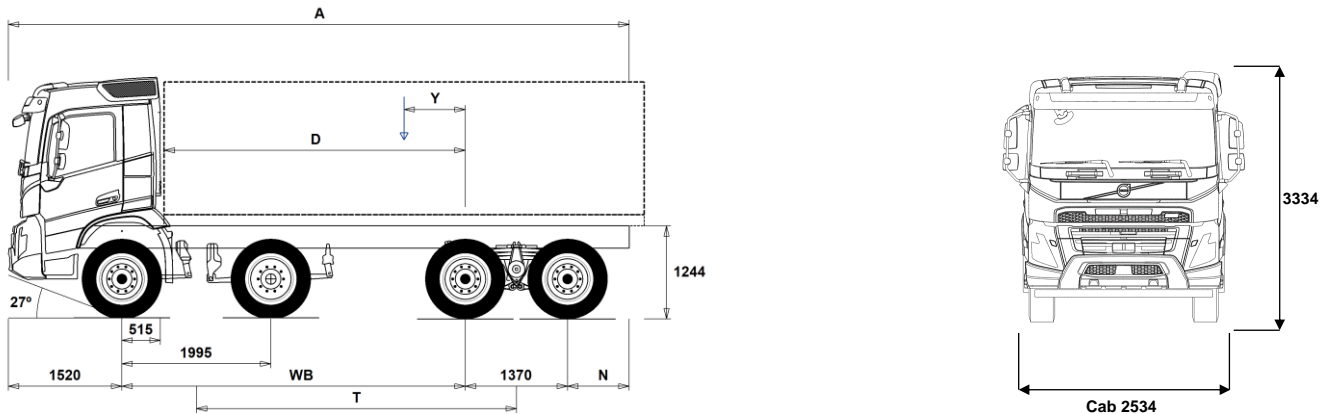

Volvo Trucks. Driving Progress

NEW FMX13 8x6 Rigid - B/T Ride - N3 or N3G FMX 86RF 3L



## Chassis Dimensions [mm]

WB Wheelbase	4600	4900	5100	5600
A Overall Chassis Length	8315	8615	8815	9315
D Center of rear axle to front of body	4035	4335	4535	5035
N Rear Overhang (Min.)	1225	1225	1225	1225
N Rear Overhang (Max.)	825	825	825	825
T Theoretical Wheelbase	4288	4588	4788	5288
Y Center of Gravity for Payload (Min.)	57	117	155	254
Y Center of Gravity for Payload (Max.)	1192	1333	1427	1662

## Chassis Weights [kg]

Front Axles	7480	7455	7445	7410
Rear Bogie	2915	2975	3015	3090
Kerb Weight	10395	10430	10460	10500
Payload (including body, driver, fuel, etc.)	19455	19420	19390	19350

## Turning Diameter [mm]

Turning Circle Diameter Kerb to Kerb	18200	19200	19800	21300
Turning Circle Diameter Wall to Wall	19700	20600	21300	22800

## Plated Weights [kg]

	Plated	Design
Gross Vehicle Weight	29850	37000
Gross Combination Weight	44000	60000
Front Axles	16000	16000
Rear Bogie	19000	21000

## Important Notes

### Chassis Dimensions

Cab Height: +328 mm for CAB-HSLP, -262 mm for CAB-LDAY, -262 mm for CAB-LSLP, +16 mm for CAB-SLP.

Front Axle to Back of Cab: +431 mm for CAB-HSLP and CAB-SLP, -69 mm for CAB-LDAY, +425 mm for CAB-LSLP.

D-measure includes a front clearance of 50 mm and for rigid trucks also a subframe of 100 mm.

Height can vary  $\pm 20$  mm for leaf and  $\pm 10$  mm for air suspension.

All dimensions are for unladen chassis and any tag axles down.

Rear overhang used for vehicle weight calculation is the maximum rear overhang (N Max.) for selected wheelbase.

Weight and dimensions are based upon the following tyres:

Front Axle Tyres: 315/80R22.5  
Drive Axle Tyres: 315/80R22.5

**Chassis weight includes oil, water, AdBlue, 0 litres fuel and without driver. Kerb weight can vary  $\pm 3\%$ .**

Turning diameters are theoretically calculated.

Legal weights can differ from country to country.

For more detailed weight information, including optional equipment weights, ask your Volvo sales contact to enter your specification into the Volvo Weight Information system (WIS).

Do NOT use this drawing for bodybuilding. Refer to Volvo Bodybuilder Instructions and chassis assembly drawing FMX86RF3L.

# MODEL RANGE

## NEW FMX13 8x6 Rigid - B/T Ride - N3 or N3G FMX 86RF 3L

### TRUCK USE

- **RC-ROUGH** Road conditions - On / off-road
- **RC-VROUG** Road conditions - Very rough
- **TIPP-PRE** Transport Adaption - Tipper vehicle preparation
- **UNIFORM** Transport Adaption - Basic platform vehicle

### CORE COMPONENTS

- **RADD-BR** Rear suspension - B-ride rear three spring bogie
- **RADD-TR1** T-ride 1 rear two spring bogie suspension, 75mm wide springs
- **RADD-TR2** T-ride 3 rear two spring bogie suspension, reinforced
- **RADD-TR3** RADD-TR3 - T ride 3
- **FMX-DAY5** Cab - Day - with steel safety cage design  
Designed and built to Swedish impact and ECE R29 regulations
- **FMX-HSL5** Cab - Globetrotter - with steel safety cage design  
Designed and built to Swedish impact and ECE R29 regulations
- **FMX-LDA5** Cab - Low Day - with steel safety cage design  
Designed and built to Swedish impact and ECE R29 regulations
- **FMX-LSL5** Cab - Low Sleeper - all-steel safety cage design.  
Built to Swedish impact and ECE R29 regulations
- **FMX-SLP5** Cab - Sleeper - with steel safety cage design  
Designed and built to Swedish impact and ECE R29 regulations
- **EU6SCR** Emission level - Euro VI step E
- **D13 420S** Engine - D13K420 12.8 litre developing 420hp at 14-1800rpm.  
Peak torque 2100Nm at 860 -1400rpm.
- **D13 460S** Engine - D13K460 12.8 litre developing 460hp at 14-1800rpm.  
Peak torque 2300Nm at 900-1400rpm.
- **D13 500S** Engine - D13K500 12.8 litre developing 500hp at 14-1800rpm.  
Peak torque 2500Nm at 1000-1400rpm.
- **D13 540S** Engine - D13K540 12.8 litre developing 540hp at 14-1800rpm.  
Peak torque 2600Nm at 1000-1450rpm.
- **D13K420** D13K420 - 420hp engine
- **D13K460** D13K460 - 460hp engine
- **D13K500** D13K500 - 500hp engine
- **D13K540** D13K540 - 540hp engine
- **EBR-EPG** Engine Brake Type - Exhaust brake controlled by steering column switch
- **EBR-EPGC** Engine Brake Type - Exhaust pressure governor for I shift gearbox
- **EBR-VEB+** Engine Brake Type - Volvo engine brake + and exhaust pressure governor, enhanced performance from additional exhaust rocker control. Retardation 375kW
- **AT2612F** Gearbox - AT2612F 12-speed "I-shift" automated mechanical suitable for gross train weights up to 60tonne only.  
Refer to sales engineering when used in conjunction with a PTO
- **ATO2612F** Gearbox - ATO2612F 12-speed "I-shift" overdrive automated mechanical, suitable for gross train weights up to 60tonne.  
Refer to sales engineering when used in conjunction with a PTO
- **PT2606** Gearbox - Powertronic automatic 6-speed, max. engine torque 2600 Nm, max. permitted GCW 130000 kg
- **ASO-C** Crawler gear -  
Ratio direct top gearbox 19:1  
Ratio Overdrive gearbox 17:1
- **ASO-ULC** Ultra low crawler and crawler gear -  
Ratios direct top gearbox 32:1 and 19:1  
Ratios Overdrive box 32:1 and 17:1
- **RTH2610B** Drive Axles - RTH2610B 26-tonne hub reduction tandem with differential and cross locks\* - design GCW 100tonne, 4 planetary gears  
\* Cross locks replaced by a dog clutch if tandem axle lift is specified.
- **RTH2610F** Drive Axles - RTH2610F 26-tonne hub reduction tandem with differential and cross locks\* - design GCW 100tonne  
\* Cross locks replaced by a dog clutch if tandem axle lift is specified.

- **RTH3210F** Drive Axles - RTH3210F 32-tonne hub reduction tandem with differential and cross locks\* - design GCW 100 tonne  
\* Cross locks replaced by a dog clutch if tandem axle lift is specified.
- **RTH3312** Drive Axles - RTH3312 33-tonne hub reduction tandem with differential and cross locks\* - design GCW 120tonne  
\* Cross locks replaced by a dog clutch if tandem axle lift is specified.
- **RTH3815** Drive Axles - RTH3815 38-tonne hub reduction tandem with differential and cross locks - design GCW 150 tonne

### PACKAGES

- **DRIVE5** Drive Package
- **DRIVE5+** Drive+ Package
- **DRIVE5++** Drive++ Package
- **1LIVINFM** Sleep & Resting Package - Living one-bed
- **2LIVINFM** Sleep & Resting Package - Living two-bed
- **INFOBAS** Basic media package without secondary display
- **INFODF** Media Information Platform with Dynafleet Support
- **INFOMED** Media Information Platform - Medium level
- **INFONAV** Media Information Platform with Navigation
- **INFONDF** Media Information Platform with Navigation & Dynafleet Support

### CHASSIS

- **FST-PAR3** Front suspension type - 3 leaf parabolic springs
- **FAL16.0** Front axle design capacity - 16 tonnes - 2 x 8 tonne front axles
- **FAL18.0** Front axle design capacity - 18 tonnes - 2 x 9 tonne front axles - check tyre load index
- **FAL20.0** Front axle design capacity - 20 tonnes - 2 x 10 tonne front axles - check tyre load index
- **FSM-LUB** Front suspension maintenance - Lubricated rear shackles on pins and bushings
- **FSTAB** Front anti-roll bar - Normal stiffness
- **RAL21** Rear bogie design capacity - 21 tonne
- **RAL26** Rear bogie design capacity - 26 tonne
- **RAL32** Rear bogie design capacity - 32 tonne
- **RAL38** Rear Bogie Design Capacity - 38 tonne
- **RSTAB1** Rear anti-roll bar - Normal stiffness
- **RSAP2** Rear suspension application - Heavy duty with reinforcements
- **PSS-DUAL** Power steering system - Dual
- **PSP-VAR** Power steering pump - Variable displacement
- **EBS-MED** Brake package - EBS medium including "hill" hold function
- **AUXPARK** Auxiliary parking brake - Additional spring brakes
- **RST-MUL** Rear suspension type - Multi-leaf spring
- **RST-PAR1** Rear suspension type - Parabolic springs
- **RST-PAR5** Rear suspension type - Progressive parabolic springs
- **FST8080** Chassis frame thickness - 8 mm web and flange
- **FIL-EEEB** Chassis frame inner liner - From the end of the engine to the end of the bogie
- **FIL-EEEF** Chassis frame inner liner - From the end of the engine to end of the frame
- **FIL-FBEB** Chassis frame inner liner - Over the rear bogie
- **FIL-FBEF** Chassis frame inner liner - From the front of bogie to the end of the frame
- **FIL-TXEB** Chassis frame inner liner - From gearbox member to the end of the bogie
- **FIL-TXEF** Chassis frame inner liner - From gearbox member to the end of the frame
- **BBOX-L** Battery box position - Left hand side
- **2BAT210B** Battery Capacity - 2 x 210 Ah - Gel type
- **2BAT210C** Battery Capacity - 2 x 210 Ah - AGM Absorbent Glass-fibre Material type
- **BATTAMP** Battery management - Voltage and current gauge
- **BATTIND** Battery management - Charge indicator

- Standard Equipment
- Optional Equipment

For more detailed information about cab and powertrain equipment, please refer to separate specification sheets.

For all possible options and combinations of options please consult your Volvo sales contact who can create a specification to match your requirements using the Volvo Sales Support system (VSS).

The factory reserves the right to modify design and change equipment without previous notification. The specification can vary from country to country.

# MODEL RANGE

NEW FMX13 8x6 Rigid - B/T Ride - N3 or N3G FMX 86RF 3L

- **MSWI-C** Battery master switch - Chassis mounted toggle by the battery box
  - **MSWI-R** Battery master switch - Key fob operated remote controlled
  - **UR-FUEL** Without right-hand fuel tank  
Min volume 255l  
Max volume 630l
  - **UL-FUEL** Without left fuel tank
  - **ADTP-L** AdBlue tank position - Chassis mounted on the left-hand side
  - **ADTP-LF** AdBlue tank position - Chassis mounted on the left-hand side between axle 1 and 2
  - **ADTP-R** AdBlue tank position - Chassis mounted on the right-hand side
  - **ADB032** Plastic AdBlue tank - 32 litres
  - **FCAP-L** Diesel and AdBlue filler cap - Locking
  - **FUFF-AS** Fuel filler - Anti-spill device
  - **FUFF-ATS** Fuel filler - Anti-spill & anti-syphon device
  - **ESH-REAR** Exhaust - Horizontal silencer - rear outlet
  - **ESH-VERT** Exhaust - Horizontal silencer - vertical outlet
  - **EXST-SSP** Stainless steel exhaust stack - NOT polished
  - **EXST-ST** Steel exhaust stack
  - **WHC-FIX2** Wheel chocks - Two fixed design
  - **WHC-FOL2** Two foldable wheel chocks
  - **WHCP-F** Wheel chock carrier position - In the front part of the vehicle
  - **WHCP-R** Wheel chock carrier position - In the rear part of the vehicle
  - **WHCP-T** Wheel chock carrier position - Outer luggage locker
  - **TB-L80** Toolbox 800 mm, left side
  - **TB-R80** Toolbox 800 mm, right side
  - **CHAIN-S** Snow chains
  - **HOOK-SC** Snow chain hooks
  - **TOWMBRH** Towing member, high mounted in centre of frame, D = 190
  - **TOWMBRL1** Towing member, low mounted under the frame
  - **TOWMBRM** Towing member, medium mounted in line with frame lower flange
  - **RFEC-S** Rear frame profile - Straight cut
  - **RFEC-U** Rear frame profile - Slight uppercut for tipplers
  - **C-RI4040** Towing coupling, Ringfeder 4040 G-150
  - **C-RI5055** Towing coupling, Ringfeder 5055 G-150
  - **C-RO400G** Towing coupling, Rockinger 400 G-150 for 40mm eyes
  - **C-RO50** Rockinger RO 50 50mm for centre axle trailer
  - **TOWR-ONE** Towing hitch attached to rear crossmember
  - **TREL-PK** Trailer electrical preparation kit - chassis/cab wiring
  - **TREL14** Single 14 pole electrical trailer connector
  - **TREL15** Trailer electrical connection - Single 15 pin - ADR certified
  - **TREL7** 7 pole - 24N trailer electrical suzie
  - **TREL7-7** Trailer electrical connection - 2 x 7 pin - 24N and 24S
  - **TBC-DUO** Duomatic type air line connectors
  - **TBC-EC** Trailer brakes with EC palm coupling connectors
  - **TRBR-HCF** Full pressure hand controlled trailer brake
  - **TRBR-STA** Stationary trailer brake control
  - **TRB-STRE** Stretch Brake - Automatic low speed trailer brake activation to avoid jack-knifing and improve steerability
  - **FFEND-T** Transport mounted mud wings on second front axle
  - **RFEND-B** Three piece EC approved rear mud wings and spray flaps
  - **RFEND-T** Rear mud wings - Temporary on drive axle for transport delivery only
  - **RFH-BAS** Basic rear wing height
  - **RFH-HIG** High rear wing height - higher wing tops
  - **RFH-LOW** Lower rear wing height - shallower wing tops
  - **ATANK-ST** Air tanks - Steel
  - **TL-LED** Rear lights - LED
  - **BLIGHT-E** Emergency brake light
- ## WHEELS & TYRES
- **RT-SPOKE** Spoke rims on all axles
  - **RT-STEEL** Wheels - Steel rims
  - **SPWT-D** Spare wheel & tyre with rear tyre pattern
  - **SPWT-F** Spare wheel & tyre with front tyre pattern
  - **SWCP-T** Spare wheel supplied temporarily strapped to chassis
  - **SWCP-TP** Temporary spare wheel carrier on top of chassis frame
  - **JACK-20T** 20 tonne bottle jack
  - **TOOL-BAS** Basic Toolkit
  - **TOOLKIT** Complete tool kit
  - **INFLAHOS** Tyre inflation hose
  - **GAUGE-TP** Tyre pressure gauge
- ## DRIVELINE EQUIPMENT
- **TRAP-HD** Reinforced gearbox application
  - **DRM-BE** Balanced & Economy Drive Mode
  - **DRM-E** Economy Drive Mode
  - **PVT-MAP** I-See Predictive Cruise Control - using map based topography information
  - **CRUIS-E** Eco cruise control (with eco-roll and I-cruise, controls in steering wheel)
  - **CRUIS-E5** Eco torque software - Improved economy mode. Fuel economy optimized cruise control for I-Save
  - **CRUISEC** Cruise control, standard
  - **AMSO-AUT** Enhanced I-shift software with manual shift available in auto mode and kickdown facility on accelerator pedal
  - **AVO-ENH** I-Shift application software - for construction and off road applications
  - **APF-ENH** I-shift enhanced PTO functions
  - **RET-TPT** Hydraulic Retarder for Powertronic gearbox
  - **TC-HWO** Transmission oil cooler - water to oil
  - **TC-MAOH2** Extra high performance transmission oil cooler - air to oil with front mounted radiator
  - **TC-MWO** Basic transmission oil cooler - water to oil
  - **1COMP530** Air compressor - One-cylinder 530 litres per minute
  - **2COM1100** Air compressor - Two-cylinder 1100 litres per minute
  - **2COMP900** Air compressor - Two-cylinder 900 litres per minute
  - **CLU-AIRC** Clutchable air compressor
  - **AIRIN-HI** Air intake - Roof-mounted behind cab on the left-hand side
  - **AIRIN-LO** Low level air intake behind cab on left hand side
  - **ACL1ST-S** Air filter - two-stage element
  - **24AL110B** Alternator capacity - 110 amp
  - **24AL120B** Alternator capacity - 120 amp alternator
  - **24AL150B** Alternator capacity - 150 amp
  - **CCV-C** Closed crankcase engine ventilation
  - **CCV-OX** Closed crankcase ventilation for cold markets
  - **PRIM-EL** Electrical priming pump
  - **PRIM-MAN** Manual priming pump
  - **FUEQ-EH** Fuel line electric heater
  - **AF-R** Hot fuel recirculation heated fuel filter
  - **FUEFE2LW** Large engine mounted dual fuel filter with water separator
  - **FUEFE2SW** Small engine mounted dual fuel filter with water separator
  - **EST-AID** Engine starting aid -Preheating element in the air inlet manifold
  - **220EBH15** 220V/1.5Kw electric engine block heater
  - **PTER-100** Engine power-take-off - Rear-mounted with DIN100/ISO7646 flange

■ Standard Equipment

□ Optional Equipment

For more detailed information about cab and powertrain equipment, please refer to separate specification sheets.

For all possible options and combinations of options please consult your Volvo sales contact who can create a specification to match your requirements using the Volvo Sales Support system (VSS).

The factory reserves the right to modify design and change equipment without previous notification. The specification can vary from country to country.

# MODEL RANGE

## NEW FMX13 8x6 Rigid - B/T Ride - N3 or N3G FMX 86RF 3L

- PTER-DIN** Engine power-take-off - Rear-mounted with DIN5462 (female) splined shaft for a close-coupled pump  
Models with 3 steering axles will use this to drive the steering pump (AUXPSP)
- PTER1400** Engine power-take-off - Rear-mounted with SAE 1410 flange
- HPE-F101** Parker F1-101, engine mounted, fixed displacement, single flow, engine mounted hydraulic pump
- HPE-F41** Parker F1-41, engine mounted, fixed displacement, single flow, engine mounted hydraulic pump
- HPE-F51** Parker F1-51, engine mounted, fixed displacement, single flow, engine mounted hydraulic pump
- HPE-F61** Parker F1-61, engine mounted, fixed displacement, single flow, engine mounted hydraulic pump
- HPE-F81** Parker F1-81, engine mounted, fixed displacement, single flow, engine mounted hydraulic pump
- HPE-T53** Parker F2-53/53, engine mounted, Fixed displacement, Twin flow engine mounted hydraulic pump
- HPE-T70** Parker F2-70/35, engine mounted, Fixed displacement, Twin flow engine mounted hydraulic pump
- HPE-V45** Parker VP1-45, variable displacement, single flow, engine mounted hydraulic pump
- HPE-V75** Parker VP1-75, variable displacement, single flow, engine mounted hydraulic pump
- PTPT-D** Powertronic PTO, 1 front/upper DIN connection for plug-in pump (max. 850 Nm)
- PTPT-F** Powertronic PTO, 1 front/upper rear facing SAE flange conn. for prop shaft (max.850 Nm)
- PTR-D** Gearbox PTO for plug-in pump, 0.71xeng speed
- PTR-DH** Gearbox driven high speed PTO for one plug-in hydraulic pump
- PTR-DM** Gearbox driven medium speed PTO for one plug-in hydraulic pump
- PTR-F** Gearbox driven PTO with rear flange connection
- PTRD-D** Gearbox driven HIGH SPEED PTO for two plug-in hydraulic pumps
- PTRD-F** PTO with 1 DIN + 1 flange connection rear, manual gearbox
- HPG-F101** Parker F1-101 gearbox mounted, fixed displacement, single flow, hydraulic pump
- HPG-F41** Parker F1-41 gearbox mounted, fixed displacement, single flow, hydraulic pump
- HPG-F51** Parker F1-51 gearbox mounted, fixed displacement, single flow, hydraulic pump
- HPG-F61** Parker F1-61 gearbox mounted, fixed displacement, single flow, hydraulic pump
- HPG-F81** Parker F1-81 gearbox mounted, fixed displacement, single flow, hydraulic pump
- STWPOS-R** Steering wheel position - RIGHT-HAND DRIVE
- STWM-LE** Leather steering wheel
- STGW-AD2** Adjustable steering wheel with neck tilt
- STGW-ADJ** Adjustable steering wheel
- AIRBAG** SRS Driver's air bag
- INST-BAS** Basic level instruments
- DRC-AMI** DPF Regeneration control switch - for manual and switching off regeneration
- 1DAYDIG2** Tachograph - Continental VDO 4.0
- ARSL** Additional road speed limit - switch in dashboard
- ESP-BAS1** Electronic Stability Control
- LSS-DW** Lane departure-warning system
- DAS-W** Driver Alert Support system
- RSENS-W** Rain sensing windscreen wipers
- CU-ECC** Cab Climate Unit - Electrically controlled air conditioning with sun sensor
- CU-ECC2** Cab Climate Unit - Electrically controlled air conditioning with a carbon filter, sun, mist, and air quality sensor
- CU-MCC** Cab Climate Unit - Manual air conditioning
- IMMOBIL** Thatcham H2 approved immobiliser
- ALARM-E** Enhanced vehicle alarm - Thatcham H1 approved - Cab plus external sensor for body/trailer
- ALCOLOCK** Alcolock
- BUPMON** Back up monitor - Digital reverse camera, parameter & lead supplied loose in cab.
- PHONE-PK** Telephone preparation kit (antenna, antenna attachm. cable incl.)
- ISUNS-BS** Side sun visor - Driver & passenger side
- ISUNS-DS** Side sun visor - Driver-side
- ISUNF-B** Interior front sun visor without mirror
- ISUNF-MD** Interior front sun visor with mirror on driver side
- ISUNF-RE** Electrically operated textile interior sun blind
- ISUNF-RM** Manually operated textile interior sun blind
- ADFS** Two extra DIN slots in front shelf - can be fitted with card or drawer available as an accessory
- BUPALARM** Reverse alarm
- RTOLL-PK** Road toll PREPARATION kit for trucks operating with "Toll Collect" in Germany
- REMC-MF** Multi-functio wireless remote control
- FIREXT3S** Fire extinguisher - 3kg mounted on the seat base
- WARNVEST** High visibility warning vest - no sleeves
- AIDKIT** First aid kit - Legal demand for EU markets including delivery to EU bodybuilder
- AIDKIT1B** First aid kit - Legal demand for trucks transiting Germany
- WARNLAMP** Portable warning lamp
- LAMP-IN** Inspection lamp
- BULBKIT** Bulb and fuse kit
- WRITEPAD** Writing pad
- DST-CF4** Driver seat - Suspended, adjustable shock absorber, travel, backrest & lumbar controls - seatbelt mounted to the seat
- DST-CF5** Driver seat - Suspended with adjustable shock absorber, travel, backrest, lumbar & heat controls - seatbelt mounted to the seat
- DST-CF6** Driver seat - Suspended with adjustable shock absorber, travel, backrest, lumbar, heat and ventilation controls - seatbelt mounted to the seat
- SBD-RED** Seat belt colour - Red
- SBPRE-DS** Driver seat belt pretensioner
- PST-BAS1** Passenger seat - Fixed non suspended fold up with seatbelt mounted in cab
- PST-CF4** Passenger seat - Suspended, adjustable shock absorber, travel, backrest & lumbar controls - seatbelt mounted to the seat
- PST-CF5** Passenger seat - Suspended with adjustable shock absorber, travel, backrest, lumbar & heat controls - seatbelt mounted to the seat
- PST-STD2** Passenger seat - Fixed with backrest adjustment, non suspended with seatbelt mounted in cab
- PST-STD4** Passenger seat - Standard suspended with seatbelt mounted in cab
- SBPRE-PS** Passenger seat belt pretensioner
- ARMRE-BB** Armrests - Two on both driver & passenger seats
- ARMRE-DB** Armrests - Two on the driver seat
- ARMRE-PB** Armrests - Two on the passenger seat
- ARU-BAS** Armrest upholstery - Vinyl
- ARU-LEA** Armrest upholstery - Leather
- FMAT-RUB** Footwell floor mats - Rubber
- FMAT-TX2** Footwell floor mats - Two sets, Rubber and textile with an embossed pile supplied in the cab
- LBK70** Lower bunk 700 x2000 mm, fixed

Standard Equipment

Optional Equipment

For more detailed information about cab and powertrain equipment, please refer to separate specification sheets.

For all possible options and combinations of options please consult your Volvo sales contact who can create a specification to match your requirements using the Volvo Sales Support system (VSS).

The factory reserves the right to modify design and change equipment without previous notification. The specification can vary from country to country.

# MODEL RANGE

## NEW FMX13 8x6 Rigid - B/T Ride - N3 or N3G FMX 86RF 3L

- MATL-FI** Firm lower bunk pocket sprung mattress
  - MATL-SF** Lower flexizone mattress - semi-firm, pocket springs up to 100kg - 16 stone
  - OLMAT-BA** 35mm mattress overlay protector
  - OLMAT-PR** 50mm premium mattress overlay protector
  - TBK60F** Fixed foldable top bunk 600 x 1900mm
  - TBK70F** Fixed foldable top bunk 700 x 1900mm
  - PH-CAB2** 1.8kW Air to air night heater
  - PH-ENGCA** Engine and cab night heater
  - PH-SS** Short stop heater
  - SLCP-BAS** Sleeper control panel - Basic with switches for interior light, night heater, roof hatch and door lock
  - ETSB-F** Storage on engine tunnel - Central document box with two rear cup holders
  - ETSB-FR** Storage on engine tunnel - Central document box with two rear cup holders & open storage pocket on cab rear wall
  - ETSB-R** Storage on engine tunnel - Open storage pocket on cab rear wall
  - RUS-BAS** Rear cab upper storage - 300 mm high
  - RUS-HIG** Rear cab upper storage - 440 mm high - volume 245 litres
  - REF-ICPK** Fridge: engine tunnel mounted preparation kit
  - MICRO-PK** Wiring preparation kit for microwave oven
  - BOTH-D** One bottle holder under dashboard centre section
  - COFMA-PK** Coffee maker, preparation kit.
  - INLI-BAS** Interior white LED lights - basic
  - INLI-NL** Interior white and red night LED light with no dimmer
  - INLI-NLD** Interior white and red night LED light with dimmer
  - ARL-FLEX** Two flexible reading lamps (snake lamps)
  - RH-EE** Fixed tinted glass sky window with emergency exit
  - RH-ER** Steel roof hatch - Electrically operated, rear opening with emergency exit
  - RH-ETR** Tinted glass roof hatch - Electrically operated, rear opening with emergency exit
  - RH-MTR** Tinted glass roof hatch - Manually operated, rear opening with emergency exit
  - GLAS-TIN** Tinted windows.
  - SWIND-BS** Extra side window on both sides behind "B" pillar
  - SWIND-PS** Cab side window - Left side rear behind 'B' post
  - AWIND-RF** Rear window
  - VANMIR** Vanity mirror in front shelf
  - AS-FUS** Extra shelf in front upper storage compartments
  - INFOT-PK** Preparation kit for the mounting of a flat screen TV in cab above the driver's door, includes bracket, electrical and speaker connections
- ### CAB EXTERIOR
- EXTL-BAS** Basic exterior finish - Satin Volvo badges, grey grille, instep, bumper, bumper spoiler, grille, door handles mirror housing and sunvisor if specified.
  - DGLAS-H** Tempered door glass
  - DGLAS-L** Laminated door glass
  - LOCK-CTL** Door locks - Central locking with key
  - LOCK-REM** Door locks - Remote central locking
  - BUMP-HD** Heavy duty front bumper
  - AUXFS** Lower swinging cab step
  - GUARD-EH** Engine guard to protect sump and engine hoses
  - BUGNET** Insect screen in front of radiator
  - CTILT-P-E** Electrically operated hydraulic cab tilt
  - CTILT-P-M** Manually operated hydraulic cab tilt
- FCABS-A** Front cab suspension - Air
  - FCABS-M** Front cab suspension - Mechanical spring
  - RCABS-A** Rear cab suspension - Air
  - RCABS-M** Rear cab suspension - Mechanical spring
  - MIRCFCPX** Mirrors - Electrically heated and operated - FMX- main and wide-angle with manually adjusted kerb view mirror on the passenger side and position camera in nearside mirror arm. To increase direct vision to the side the main mirrors have no cowlings
  - MIRCOMFX** Electrically heated and operated -FMX- main and wide-angle mirrors with manually adjusted passenger kerb mirror, to increase direct vision to the side the main mirrors have no cowlings
  - MIRSTDX2** Electrically heated -FMX- main and wide-angle mirrors with manually adjusted passenger kerb mirror, to increase direct vision to the side the main mirrors have no cowlings
  - AMIR-F20** Auxiliary front view mirror with a 200mm radius
  - SUNV-H** External smoke grey sunvisor
  - AD-ROOF** Roof air deflector
  - AD-SIDES** Short cab side air deflector for rigid bodywork
  - HL-BASIC** Halogen H7 head lamps
  - HL-CLEAN** Head lamp cleaner - washer jets
  - HLP-ST** Headlamp protection
  - HL-ADJ** Headlight adjustment - Switch in cab
  - ASL-RF2** Two Hella H11 70W spotlamps in sign box - only available with the basic headlight and no lower driving lights.
  - BEACOA2F** Roof beacons - Two front roof mounted amber LED
  - BEACOA2R** Roof beacons - Two rear roof mounted amber LED
  - BEACON-P** Roof beacons - wiring preparation only
  - BEACONA4** Roof beacons - Four amber LED - two front/ two rear
  - CABPT-R1** Single outlet for roof mounted accessories
  - CABPT-R2** Twin outlets for roof mounted accessories.
  - SPOTP-F** Spotlamp preparation in front, max 280W
  - SPOTP-R** Spotlamp preparation on roof, max 280W
  - SPOTP-RF** Spotlamp preparation on cab roof and in cab front, max 2x280W
  - ROS-IL2** Preparation kit for illuminated roof sign with switch loose in cab, fit after registration
  - CSGN-FMX** "Volvo FMX" headboard logo
  - HORN-F1S** Horn - Air single tone - chassis mounted
  - HORN-R2S** Horn - Air - Two roof-mounted
  - ANT-CBR** Roof mounted antenna for CB radio, single aerial. Only Globetrotter cabs brings in extra DIN slots.
  - ACCBR-AP** Front, middle & rear roof mounted accessory brackets
  - ACCBR-F** Front roof mounted accessory bracket
  - ACCBR-FM** Front & middle roof mounted accessory brackets
  - ACCBR-FR** Front & rear roof mounted accessory brackets
  - ACCBR-M** Middle roof mounted accessory bracket
  - ACCBR-R** Rear roof mounted accessory bracket
  - ACCBR-RM** Rear & middle roof mounted accessory brackets
  - REFS-TW** White cab conspicuity markings by packed in cab
  - REFS-TY** Yellow cab conspicuity markings by packed in cab
- ### SUPERSTRUCTURE PREPARATIONS
- SRWL-PK** Chassis-mounted working lamps - Side work and reverse lamp preparation and 3 position switch - Max load 280W
  - SWL-2FW** Chassis-mounted working lamps - Two white front-mounted LED lamps
  - SWL-2RW** Chassis-mounted working lamps - Two white rear-mounted LED lamps
  - SWL-4W** Chassis-mounted working lamps - Four white front and rear-mounted LED lamps
  - SWL-PK** Chassis-mounted working lamps - Side work lamp preparation and 2 position switch - Max load 280W

■ Standard Equipment

□ Optional Equipment

For more detailed information about cab and powertrain equipment, please refer to separate specification sheets.

For all possible options and combinations of options please consult your Volvo sales contact who can create a specification to match your requirements using the Volvo Sales Support system (VSS).

The factory reserves the right to modify design and change equipment without previous notification. The specification can vary from country to country.

# MODEL RANGE

## NEW FMX13 8x6 Rigid - B/T Ride - N3 or N3G FMX 86RF 3L

---

- **WLC-H2A** Two H3/70W working lamps with amber coloured lens high mounted back of cab
- **WLC-H2W** Two H3/70W white working lamps high mounted on the back of cab
- **WLC-PKCH** Working lamp back of cab - Preparation kit - cables and switch
- **WLC-PKH** Preparation kit, cables and switch for high mounted working lamps back of cab
- **WLC-PKL** Preparation kit, cables and switch for low mounted working lamps back of cab
- **WLC-PKLH** Preparation kit - cables and switch for low and high mounted working lamps back of cab.
  
- **ECBB-HIG** Body builder electrical centre with body builder module
  
- **BBCHAS1** One 7-pole connector for Body builder interface
- **BBCHAS3** Three 7-pole connectors for Body builder interface
  
- **BEPR-T2** Body builder electrical software preparation for tipper with remote control
  
- **TD-BAS** Trailer detection WITHOUT LED sensing
- **TD-LED** Trailer detection with LED sensing
  
- **FBA-BTF** Lower front body attachments for torsionally flexible - platform body
- **FBA-BTSF** Lower front body attachments for torsionally semi-flexible body - box or curtainsider
  
- **HBA-FSFB** Holes for body attachments - flexible/semi-flexible body
- **HBA-SB** Holes for body attachments - stiff body
  
- **RBA-T2** Lower rear body attachments for helper frame
  
- **AUXL-SPK** Electrical preparation kit - wiring and switch for snow plough lights
  
- **TAILPRE2** Tail lift preparation kit, wireless remote operation
- **TAILPREP** Taillift preparation kit - cab switch and warning in driver display
  
- **AESW2** Two Body builder bistable electrical switches (marked AUX1 / AUX2)
- **AESW2PK** 2 Body builder bistable el.switches (marked AUX1/AUX2) and prep. for 4 more switches
  
- **AUXSW-4** Wiring for 4 extra switches (from Body builder electrical centre to switch positions)

### DELIVERY SERVICES

- **TGW-4GWL** Telematics gateway - GSM/GPRS/4G modem, LTE & WLAN
- **FMS-PK** Fleet Management System gateway
- **DRUT2** Driver utility app - "My Truck" - two-year subscription  
For mobile phone, tablet, with android and IOS systems.  
Only available with Volvo Connect subscription



Volvo Truck Corporation  
volvotrucks.com