

MODEL RANGE

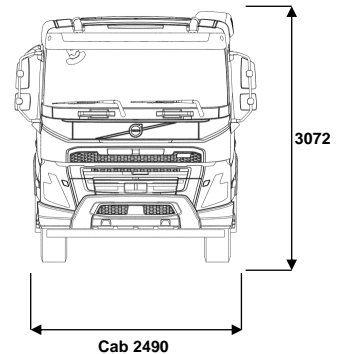

Volvo Trucks. Driving Progress

New FMx13 8x4 Rigid Air Suspension FMX 84RF 3A

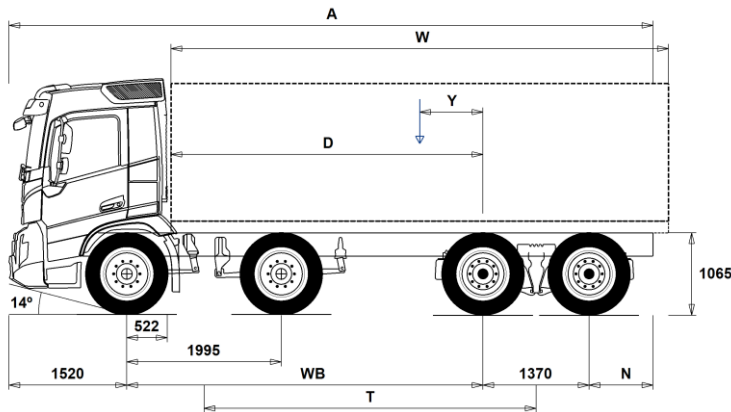

Chassis Dimensions [mm]

WB Wheelbase	4600	5100	5600
A Overall Chassis Length	8315	8815	9315
D Center of rear axle to front of body	4028	4528	5028
N Rear Overhang (Min.)	1225	1225	1225
N Rear Overhang (Max.)	825	825	825
T Theoretical Wheelbase	4288	4788	5288
Y Center of Gravity for Payload (Min.)	373	508	642
Y Center of Gravity for Payload (Max.)	373	508	642
W Body Length (Min.)	7310	8041	8772
W Body Length (Max.)	7310	8041	8772

Chassis Weights [kg]

Front Axles	6440	6410	6385
Rear Bogie	2575	2665	2730
Kerb Weight	9015	9075	9115
Payload (including body, driver, fuel, etc.)	18485	18425	18385

Turning Diameter [mm]

Turning Circle Diameter Kerb to Kerb	19000	20600	22200
Turning Circle Diameter Wall to Wall	20500	22100	23700

Plated Weights [kg]

	Plated	Design
Gross Vehicle Weight	27500	34000
Gross Combination Weight	42500	44000
Front Axles	11000	13000
Rear Bogie	16500	21000

Important Notes

Chassis Dimensions

Cab Height: +374 mm for CAB-HSLP, -204 mm for CAB-LDAY, -204 mm for CAB-LSLP, +4 mm for CAB-SLP.

Front Axle to Back of Cab: +424 mm for CAB-HSLP and CAB-SLP, -69 mm for CAB-LDAY, +418 mm for CAB-LSLP.

D-measure includes a front clearance of 50 mm and for rigid trucks also a subframe of 100 mm.

Height can vary ± 20 mm for leaf and ± 10 mm for air suspension.

All dimensions are for unladen chassis and any tag axles down. Chassis height used: CHH-HIGH.

Rear overhang used for vehicle weight calculation is the maximum rear overhang (N Max.) for selected wheelbase.

Height change when chassis height CHH-MED,FRAME300: 0 mm.

Weight and dimensions are based upon the following tyres:

Front Axle Tyres: 315/80R22.5
Drive Axle Tyres: 315/80R22.5

Chassis weight includes oil, water, AdBlue, 0 litres fuel and without driver. Kerb weight can vary $\pm 3\%$.

Turning diameters are theoretically calculated.

Legal weights can differ from country to country.

For more detailed weight information, including optional equipment weights, ask your Volvo sales contact to enter your specification into the Volvo Weight Information system (WIS).

Do NOT use this drawing for bodybuilding. Refer to Volvo Bodybuilder Instructions and chassis assembly drawing FMX84RF3A.

MODEL RANGE

New FMx13 8x4 Rigid Air Suspension FMX 84RF 3A

Core components

- **CHH-HIGH** Chassis height (high) approx 1025-1050mm (depending on tyre selection)
- **CHH-XHIGH** Chassis height (extra high) approx 1100-1162mm (depending on tyre selection)
- **RADD-G2** Rear air suspension-high clearance
- **RADD-GR** Rear air suspension
- **FMX-DAY5** Day cab
- **FMX-HSL5** Globetrotter cab
- **FMX-SLP5** Sleeper cab
- **EU5SCR-M** Eu5 SCR Selective Catalytic Reduction (mandatory)
- **D13C460** Engine, 13C litre, 460hp, 2300nm
- **D13C500** Engine, 13C litre, 500hp, 2500nm
- **D13C540** Engine, 13C litre, 540hp, 2600nm
- **EBR-VEB+** Volvo Engine Brake + (VEB+)
- **AT2612F** Volvo I-shift-12 speed automatic transmission (2600nm)
- **PT2606** Powertronic 6 speed transmission (2600nm)
- **ASO-C** Crawler gears
- **ASO-ULC** Ultra low crawler gears
- **RTH2610B** Volvo RTH2610B hub reduction rear axles
4 planet gears per hub
Axle rating: 26,000 kg
115 tonne train weight
(Application approved)
- **RTS2310A** Single reduction tandem 23t GCW100t
- **RTS2370B** Single reduction tandem 23t GCW70t

Packages

- **INFODF** Information Platform with Dynafleet Support
- **INFOMED** Information Platform-Medium
- **INFONDF** Information Platform with Navigation & Dynafleet Support

Chassis

- **FST-PAR** Parabolic leaf spring front suspension
- **FST-PAR3** 3 leaf parabolic front springs (stiffer than normal)
- **FAL13.0** Front axle rating: 13,000 kg
- **FAL16.0** Front axle load 16 tonnes
- **FAL20.0** Front axle load 20 tonnes (Non Load Share Susp.)
- **LDFA** Load sharing front suspension
- **FSTAB** Front stabilizer, normal stiffness
- **FSTAB2** Front stabiliser bar increased stiffness
- **FSTAB3** Heavy duty front stabiliser bar
- **RAL21** Rear suspension load rating: 21,000 kg
- **RAL26** Rear suspension load rating: 26,000 kg
- **RSTAB1** Rear stabiliser bar
- **RSTAB3** Heavy duty rear stabiliser bar
- **EBS-MED** Electronic Brake System (EBS) contains
ABS, Traction control, Hill start aid
Diff lock control, Brake assist
Wheel brake monitoring, EBS status
- **AUXPARK** Auxiliary parking brake
- **TRCO-12V** 24v to 12v trailer lighting voltage converter
- **TABS-12** 24v to 12v trailer ABS voltage converter
- **FST8080** Frame section thickness 8mm
- **FIL-EEEE** Liner (inner) from end of engine to end of frame
- **FIL-FBEB** Liner (inner) - front of bogie to end of bogie
- **FIL-FBEF** Liner (inner)- front of bogie to end of frame
- **FIL-TXEB** Liner (inner) - trans x-mem to end of bogie
- **FIL-TXEF** Liner (inner) - trans x-mem to end of frame
- **BBOX-L** Battery box mounted on LHS chassis rail
- **2BATT225** 2x225 Ah batteries
- **BATTAMP** Battery amperage indicator (in the DID)

■ Standard Equipment

□ Optional Equipment

For more detailed information about cab and powertrain equipment, please refer to separate specification sheets.

For all possible options and combinations of options please consult your Volvo sales contact who can create a specification to match your requirements using the Volvo Sales Support system (VSS).

The factory reserves the right to modify design and change equipment without previous notification. The specification can vary from country to country.

- **MSWI-C** Isolation toggle switch LHS of chassis
- **MSWI-R** Isolation switch on key fob (press door lock twice to isolate)
- **R415A66** RHS 415 litre alloy fuel tank w/o step
Min volume 415l
Max volume 415l
- **ADB032** AdBlue tank 32 litres
- **FCAP-L** Fuel tank cap with lock
- **ESH-RIGH** Muffler horizontal, right exhaust outlet
- **ESH-VERT** Muffler horizontal, vertical exhaust outlet on right hand side
- **EXST-SSP** Stainless steel exhaust stack
- **TRBR-HCR** Hand controlled trailer brake, reduced pressure
- **TRBR-STA** Stationary trailer brake control
- **TRB-STRE** Automatic trailer brake activation (stretch brake)
- **ATANK-AL** Aluminium airtanks
- **TL-LED** LED tail lights

Rims and Tyres

- **RT-AL** 10 stud alloy disc rims (with long wheel studs)
- **RT-ALDP** 10 stud dura-bright alloy disc rims (with long wheel studs)
- **RT-ALDPD** 10 stud dura-bright alloy disc rims (with short wheel studs)
- **RT-ALDU** 10 stud alloy disc rims (with short wheel studs)
- **RT-ALP** 10 stud polished alloy disc rims (with long wheel studs)
- **RT-ALPDU** 10 stud polished alloy disc rims (with short wheel studs)
- **RT-STEEL** 10 stud steel disc rims
- **SPWT-D** Spare rim & tyre equal to drive
- **SPWT-F** Spare rim & tyre equal to steer
- **SWCP-T2** Transport mounted spare wheel
- **JACK-12T** 12 tonne capacity jack with brace
- **JACK-15T** 15 tonne capacity jack and brace
- **TOOL-BAS** Basic tools
- **TOOLKIT** Tool kit complete
- **INFLAHOS** Tyre inflation hose (20 metres)

Powertrain equipment

- **TRAP-HD** Heavy Duty Transmission Internals
- **DRM-BE** Drive Mode - Balanced Economy
- **DRM-E** Drive Mode - Economy
- **PVT-EXT** Topography Information... by GPS positioning & central storage data
- **CRUIS-E** Extended cruise control (additional fuel saving functions)
- **CRUISEC** Cruise control
- **AMSO-AUT** Manual gear shift in automatic mode.
- **AVO-ENH** AMT Vocational option - enhanced
- **APF-ENH** Enhanced I-shift PTO functions
- **CS43B-O** Volvo 430mm single plate clutch
- **TC-HWO** Transmission Oil Cooler
- **TC-MAOH2** High performance transmission cooler
- **2COM1080** High volume air compressor
- **AIRIN-HI** High air intake, roofline position
- **AIRIN-LO** Low air intake, rear of cab position
- **ACL1ST-S** Air cleaner with two stage filter element
- **24AL120B** High capacity alternator, 120 Ampere.
- **24AL150B** Alternator - 150 Amp
- **PTER-100** PTO engine rear mounted with flange DIN100/ISO7646
- **PTER-DIN** Power Take Off / splined shaft groove (female) DIN5462.
- **PTER1400** Rear engine mounted power-take-off with flange SAE 1410
- **HPE-F101** F1-101 Hydraulic pump rear engine mounted
- **HPE-F41** F1-41 Hydraulic pump rear engine mounted

MODEL RANGE

New FMx13 8x4 Rigid Air Suspension FMX 84RF 3A

- HPE-F51** F1-51 Hydraulic pump rear engine mounted
- HPE-F61** F1-61 Hydraulic pump rear engine mounted
- HPE-F81** F1-81 Hydraulic pump rear engine mounted
- HPE-T53** F2-53/53 twin flow hyd pump rear engine mounted
- HPE-T70** F2-70/53 twin flow hyd pump rear engine mounted
- HPE-V45** V1-45 variable pump rear engine mounted
- HPE-V75** V1-75 variable pump rear engine mounted

- PTPT-D** PTO DIN / Powertronic
- PTPT-F** PTO flange conn / Powertronic
- PTR-D** Low speed PTO with DIN connection
- PTR-DH** High speed PTO with DIN connection
- PTR-DM** Medium speed PTO with DIN connection
- PTR-F** Rear PTO trans.flange 100% speed
- PTRD-D** PTO with 2 DIN connections rear + 1 DIN connection front
- PTRD-F** PTO with 1 DIN + 1 flange connection rear

- HPG-F101** F1-101 hydraulic pump gearbox mounted
- HPG-F41** F1-41 hydraulic pump gearbox mounted
- HPG-F61** F1-61 hydraulic pump gearbox mounted
- HPG-F81** F1-81 hydraulic pump gearbox mounted

- ACCLF-D** Acceleration Limiting Feature - disabled
- ACCLF-E** Acceleration Limiting Feature - enabled always
- ACCLF-S** Acceleration Limiting Feature - selectable
- ESP-BAS1** ESP package (tractor/trailer combinations with ABS. Rigid with standard COG)
- HWSS-ACB** ACC & forward collision warning & emergency braking.
- LSS-DW** With lane departure system
- LCS** Lane change support
- DAS-W** Driver alert support warning
- RSSENS-W** Rain sensor to activate wipers
- CU-ECC** Climate controlled air conditioning
- CU-MCC** Manual controlled air conditioning
- IMMOBIL** Engine immobiliser
- ALARM-B** Anti-theft alarm (cab)
- BUPMON** Back-up camera
- WLIFT-AD** Electric windows
- WLIFT-EB** Electric windows
- ISUNS-DS** Interior side sunvisor - driver's door
- ISUNF-B** Interior front sunvisor - standard
- ISUNF-MD** Interior front sunvisor - with mirror (driver's side)
- ISUNF-RE** Interior sunvisor - front (electric)
- ISUNF-RM** Interior sunvisor - front (manual)
- ADFS** 2 din slots in front shelf
- BUPALARM** Reverse alarm
- LOADIND** Load indicator, electronic controlled suspension (SUSPL-EC)
- REMC-MF** Multifunction wireless remote control
- FIREX25A** Fire extinguisher 2.5 kg
- WRITEPAD** Storable steering wheel fit clip board
- DST-CF5** Fully adjustable driver's comfort seat
Air suspension, heated, integrated safety belt
- SBD-RED** Red safety belts, pass. & driver seats
- SBPRE-DS** Drivers seat belt pretensioner
- PST-BAS1** Basic passenger's seat
- PST-BENC** Passenger bench seat
- PST-CF5** Fully adjustable passenger comfort seat
Air suspension, heated, safety belt
- SBPRE-PS** Passenger seatbelt pretensioner
- ARM-DBPS** Armrests driver's both sides - passenger side single
- ARMRE-BB** Armrests both sides - driver's & passenger's seat
- ARMRE-DB** Armrests both sides - driver's seat

- ARU-BAS** Seat armrest upholstery - basic
- GRABHI-B** Instep grab handle - standard
- FMAT-RUB** Floor mats - rubber
- FMAT-TX2** Floor mats - textile & rubber
- LBK70** Lower bunk 700mm wide
- MATL-FI** Mattress lower bunk - firm
- MATL-SF** Mattress lower bunk - semi firm
- OLMAT-BA** Mattress overlay - basic
- SAFE** Safe box at bed-end
- ETSB-F** Engine tunnel storage box
- ETSB-FR** Engine tunnel storage box & rear cab wall
- ETSB-R** Rear cab wall storage
- RUS-HIG** Rear upper cab storage - 245 litres, 440mm
- REF-ICPK** Refrigerator prep kit (on engine tunnel)
- MICRO-PK** Preparation kit for microwave
- BOTH-D** Bottle holder in driving area
- INLI-BAS** Interior night lights
- INLI-NL** Interior white and red (night) light
- INLI-NLD** Interior light including night light and dimmer function
- ARL-FLEX** Flexible reading lamp (snake light)
- RH-ER** Roof hatch-electric (metal emergency exit)
- RH-MTR** Roof hatch-manual (tinted glass & rear opening)
- SWIND-PS** Cab passenger side aux. window
- AWIND-RF** Cab rear window- fitted
- VANMIR** Vanity mirror
- AS-FUS** Auxiliary shelf, front upper storage
- INFOT-PK** LCD screen mount - 6kgs max

Cab exterior

- EXTL-BAS** Standard exterior trim level
- DGLAS-H** Hardened door glass
- DGLAS-L** Laminated door glass
- LOCK-CTL** Central door locking-Key
- LOCK-REM** Central door locking with remote control
- AUXFS** Auxiliary folding side step
- GUARD-EH** Guard plate for cooling pipes and oil sump
- BUGNET** Insect net in front of radiator
- CTILTPE** Electrical cab tilt pump
- FCABS-A** Front cab suspension-air bellows
- FCABS-M** Front cab suspension-mechanical spring
- RCABS-A** Rear cab suspension-air bellows
- RCABS-M** Rear cab suspension-mechanical spring
- MIRCOMFX** Electrically heated & operated convex glass mirrors
- MIRFLACP** Electrically heated & operated flat glass mirrors with front monitoring camera on passenger side.
- AMIR-F20** Close view mirror
- SUNV-H** Exterior sunvisor
- AD-ROOF** Aero-dynamic roof mounted deflector
- AD-SIDES** Aero-dynamic cab side deflectors
- GUARD-W** Windscreen stoneguard
- HL-BASIC** Standard head lamps
- HL-CLEAN** Head lamp cleaning system
- HLP-ST** Headlamp protection-steel

Standard Equipment

Optional Equipment

For more detailed information about cab and powertrain equipment, please refer to separate specification sheets.

For all possible options and combinations of options please consult your Volvo sales contact who can create a specification to match your requirements using the Volvo Sales Support system (VSS).

The factory reserves the right to modify design and change equipment without previous notification. The specification can vary from country to country.

MODEL RANGE

New FMx13 8x4 Rigid Air Suspension FMX 84RF 3A

- **HLP-ST2** Headlamp protection-steel/wire mesh (non ADR compliant)
- **HL-ADJ** Headlight adjustment - manual
- **DRL-LED** V-shaped LED daytime running light
- **IDLAMP-A** Identification lamps-amber
- **BEACON-P** Beacon light wire preparation
- **SPOTP-F** Aux spotlight preparation, 280W maximum
- **ANT-CBR** Antenna for CB radio, single antenna

Superstructure

- **SRWL-2RW** 2 white rear chassis mounted working lamps
- **SRWL-PK** Wiring prep for chassis mounted reverse/working lamps-3 position switch
- **SWL-2FW** 2 white side working lamps (forward facing)
- **SWL-2RW** 2 white side working lamps (rearward facing)
- **SWL-4W** 4 white side working lamps
- **SWL-PK** Wiring prep for chassis-mounted working lamps-2 position switch

- **WL-CHPK** Chassis mounted working lamp prep kit
- **WLC-H2W** 2 x H3/70W high mounted work lamps with white lens.
- **WLC-PKH** Prep kit for high mounted work lamps.

- **ECBB-HIG** Body builder module - cab module
- **BBCHAS3** Body builder chassis electrical interface, 3 x 7 pin connectors
- **BEPR-T2** Body Builder electrical prep. for tipper with remote control
- **AESW2** 2 flexible switches (AUX1 and AUX2).
- **AESW2PK** 2 flexible switches (AUX1 & AUX2) + additional 4 flexible switches

- **AUXSW-4** 4 extra bi-stable switches wired to BBM

Delivery services

- **TGW-4GWL** Telematics Gateway with 4G/LTE & WLAN
- **FMS-PK** Fleet management system gateway
- **DRUT2** "My Truck" smartphone app. 2 year prepaid



Volvo Truck Corporation
volvotrucks.com