

# MODEL RANGE

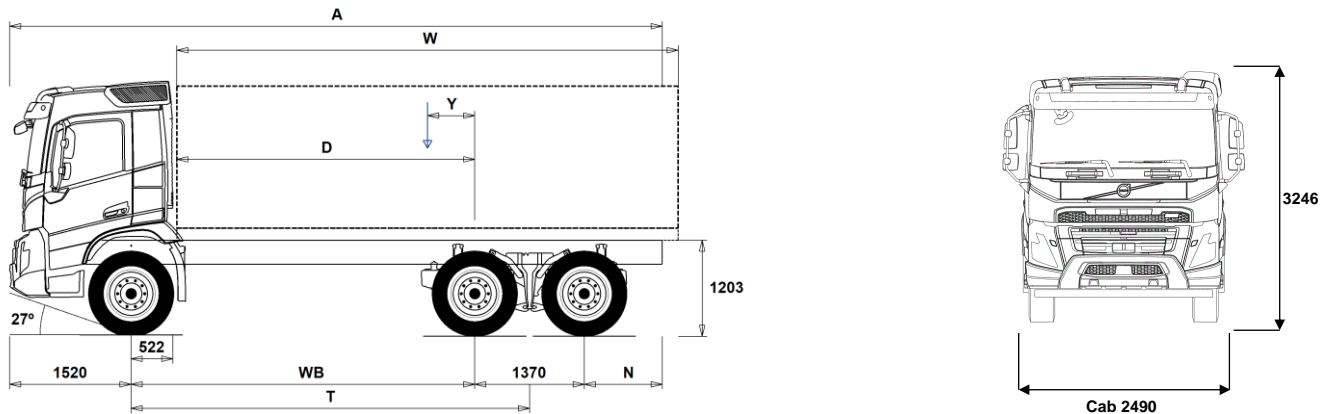

Volvo Trucks. Driving Progress

New FMx11 6x6 Rigid Air Suspension FMX 66R 1A



## Chassis Dimensions [mm]

WB Wheelbase	3700	3900	4300	4600
A Overall Chassis Length	7565	7765	8165	8465
D Center of rear axle to front of body	3128	3328	3728	4028
N Rear Overhang (Min.)	1225	1225	1225	1225
N Rear Overhang (Max.)	975	975	975	975
T Theoretical Wheelbase	4385	4585	4985	5285
Y Center of Gravity for Payload (Min.)	-244	-229	-204	-185
Y Center of Gravity for Payload (Max.)	-244	-229	-204	-185
W Body Length (Min.)	6444	6764	7404	7884
W Body Length (Max.)	6444	6764	7404	7884

## Chassis Weights [kg]

Front Axle	5105	5125	5175	5200
Rear Bogie	4035	4050	4070	4080
Kerb Weight	9140	9175	9245	9280
Payload (including body, driver, fuel, etc.)	13860	13825	13755	13720

## Turning Diameter [mm]

Turning Circle Diameter Kerb to Kerb	15500	16100	17300	18200
Turning Circle Diameter Wall to Wall	17000	17600	18800	19700

## Plated Weights [kg]

	Plated	Design
Gross Vehicle Weight	23000	35000
Gross Combination Weight	42500	60000
Front Axle	6500	9000
Rear Bogie	16500	26000

## Important Notes

### Chassis Dimensions

Cab Height: +374 mm for CAB-HSLP, -204 mm for CAB-LDAY, -204 mm for CAB-LSLP, +4 mm for CAB-SLP.  
 Front Axle to Back of Cab: +424 mm for CAB-HSLP and CAB-SLP, -69 mm for CAB-LDAY, +418 mm for CAB-LSLP.  
 D-measure includes a front clearance of 50 mm and for rigid trucks also a subframe of 100 mm.  
 Height can vary  $\pm 20$  mm for leaf and  $\pm 10$  mm for air suspension.  
 All dimensions are for unladen chassis and any tag axles down.  
 Rear overhang used for vehicle weight calculation is the maximum rear overhang (N Max.) for selected wheelbase.

Weight and dimensions are based upon the following tyres:  
 Front Axle Tyres: 315/80R22.5  
 Drive Axle Tyres: 315/80R22.5

**Chassis weight includes oil, water, AdBlue, 0 litres fuel and without driver. Kerb weight can vary  $\pm 3\%$ .**

Turning diameters are theoretically calculated.

Legal weights can differ from country to country.

For more detailed weight information, including optional equipment weights, ask your Volvo sales contact to enter your specification into the Volvo Weight Information system (WIS).

Do NOT use this drawing for bodybuilding. Refer to Volvo Bodybuilder Instructions and chassis assembly drawing FMX66R1A.

# MODEL RANGE

## New FMx11 6x6 Rigid Air Suspension FMX 66R 1A

### Truck use

- TIPP-PRE** Tipper preparation
- UNIFORM** Basic uniform vehicle

### Core components

- CHH-XXHI** Chassis height (extra extra high) approx 1158-1189mm (depending on tyre selection)
- RADD-G2** Rear air suspension-high clearance
- FMX-DAY5** Day cab
- FMX-SLP5** Sleeper cab
- EU5SCR-M** Eu5 SCR Selective Catalytic Reduction ( mandatory )
- D11C410** Eu5 11 litre engine 410hp/1950 Nm/302kW
- D11C450** Eu5 11 litre engine 450hp/2150 Nm/332kW
- EBR-VEB** Volvo Engine Brake (VEB)
- AT2612F** Volvo I-shift-12 speed automatic transmission (2600nm)
- PT2106** Powertronic 6 speed transmission (2100nm)
- RTH2610B** Volvo RTH2610B hub reduction rear axles  
4 planet gears per hub  
Axle rating: 26,000 kg  
115 tonne train weight  
(Application approved)

### Packages

- INFODF** Information Platform with Dynafleet Support
- INFOMED** Information Platform-Medium
- INFONDF** Information Platform with Navigation & Dynafleet Support

### Chassis

- FST-PAR3** 3 leaf parabolic front springs (stiffer than normal)
- FAL10.0** Front axle load 10 tonnes
- FAL9.0** Front axle load 9.0 tonnes
- FSTAB** Front stabilizer, normal stiffness
- RAL26** Rear suspension load rating: 26,000 kg
- RSTAB3** Heavy duty rear stabiliser bar
- PSP-FIX** Power steering pump with fixed displacement
- EBS-MED** Electronic Brake System (EBS) contains  
ABS, Traction control, Hill start aid  
Diff lock control, Brake assist  
Wheel brake monitoring, EBS status
- AUXPARK** Auxiliary parking brake
- FST8080** Frame section thickness 8mm
- FIL-EEEF** Liner (inner) from end of engine to end of frame
- FIL-TXEB** Liner (inner) - trans x-mem to end of bogie
- BBOX-L** Battery box mounted on LHS chassis rail
- 2BATT225** 2x225 Ah batteries
- BATTAMP** Battery amperage indicator (in the DID)
- MSWI-C** Isolation toggle switch LHS of chassis
- MSWI-R** Isolation switch on key fob (press door lock twice to isolate)
- R415A66** RHS 415 litre alloy fuel tank w/o step  
Min volume 415l  
Max volume 415l
- ADB064** AdBlue tank 64 litres
- FCAP-L** Fuel tank cap with lock
- ESH-REAR** Horizontal muffler with low rear facing outlet
- ESH-VERT** Muffler horizontal, vertical exhaust outlet on right hand side
- EXST-SSP** Stainless steel exhaust stack
- TL-LED** LED tail lights

### Rims and Tyres

- Standard Equipment
- Optional Equipment

For more detailed information about cab and powertrain equipment, please refer to separate specification sheets.

For all possible options and combinations of options please consult your Volvo sales contact who can create a specification to match your requirements using the Volvo Sales Support system (VSS).

The factory reserves the right to modify design and change equipment without previous notification. The specification can vary from country to country.

- RT-STEEL** 10 stud steel disc rims
- SPWT-D** Spare rim & tyre equal to drive
- SPWT-F** Spare rim & tyre equal to steer
- SWCP-T2** Transport mounted spare wheel
- JACK-20T** Jack, 20 tonnes
- TOOL-BAS** Basic tools
- TOOLKIT** Tool kit complete
- INFLAHOS** Tyre inflation hose (20 metres)

### Powertrain equipment

- TRAP-HD** Heavy Duty Transmission Internals
- DRM-BE** Drive Mode - Balanced Economy
- DRM-E** Drive Mode - Economy
- PVT-EXT** Topography Information... by GPS positioning & central storage data
- CRUIS-E** Extended cruise control (additional fuel saving functions)
- CRUISEC** Cruise control
- AMSO-AUT** Manual gear shift in automatic mode.
- AVO-ENH** AMT Vocational option - enhanced
- APF-ENH** Enhanced I-shift PTO functions
- CS43B-O** Volvo 430mm single plate clutch
- TC-HWO** Transmission Oil Cooler
- TC-MAOH2** High performance transmission cooler
- 2COM1080** High volume air compressor
- AIRIN-HI** High air intake, roofline position
- AIRIN-LO** Low air intake, rear of cab position
- ACL1ST-S** Air cleaner with two stage filter element
- 24AL120B** High capacity alternator, 120 Ampere.
- 24AL150B** Alternator - 150 Amp
- PTER-100** PTO engine rear mounted with flange DIN100/ISO7646
- PTER-DIN** Power Take Off / splined shaft groove (female) DIN5462.
- PTER1400** Rear engine mounted power-take-off with flange SAE 1410
- HPE-F101** F1-101 Hydraulic pump rear engine mounted
- HPE-F41** F1-41 Hydraulic pump rear engine mounted
- HPE-F51** F1-51 Hydraulic pump rear engine mounted
- HPE-F61** F1-61 Hydraulic pump rear engine mounted
- HPE-F81** F1-81 Hydraulic pump rear engine mounted
- HPE-T53** F2-53/53 twin flow hyd pump rear engine mounted
- HPE-T70** F2-70/53 twin flow hyd pump rear engine mounted
- HPE-V45** V1-45 variable pump rear engine mounted
- HPE-V75** V1-75 variable pump rear engine mounted
- PTPT-D** PTO DIN / Powertronic
- PTPT-F** PTO flange conn / Powertronic
- PTR-D** Low speed PTO with DIN connection
- PTR-DH** High speed PTO with DIN connection
- PTR-DM** Medium speed PTO with DIN connection
- PTR-F** Rear PTO trans.flange 100% speed
- PTRD-D** PTO with 2 DIN connections rear + 1 DIN connection front
- PTRD-D1** PTO with 1 DIN + 1 flange connection rear + 1 DIN connection front
- PTRD-D2** PTO with 2 flange connection rears + 1 DIN connection front
- HPG-F101** F1-101 hydraulic pump gearbox mounted
- HPG-F41** F1-41 hydraulic pump gearbox mounted
- HPG-F61** F1-61 hydraulic pump gearbox mounted
- HPG-F81** F1-81 hydraulic pump gearbox mounted
- RSENS-W** Rain sensor to activate wipers
- CU-ECC** Climate controlled air conditioning
- CU-MCC** Manual controlled air conditioning
- IMMOBIL** Engine immobiliser
- ALARM-B** Anti-theft alarm (cab)

# MODEL RANGE

## New FMx11 6x6 Rigid Air Suspension FMX 66R 1A

- BUPMON** Back-up camera
  - WLIFT-AD** Electric windows
  - WLIFT-EB** Electric windows
  - WLIFT-ME** Manual windows
  - ISUNS-DS** Interior side sunvisor - driver's door
  - ISUNF-B** Interior front sunvisor - standard
  - ISUNF-MD** Interior front sunvisor - with mirror (driver's side)
  - ISUNF-RE** Interior sunvisor - front (electric)
  - ISUNF-RM** Interior sunvisor - front (manual)
  - ADFS** 2 din slots in front shelf
  - BUPALARM** Reverse alarm
  - LOADIND** Load indicator, electronic controlled suspension (SUSPL-EC)
  - REMC-MF** Multifunction wireless remote control
  - FIREX25A** Fire extinguisher 2.5 kg
  - WRITEPAD** Storable steering wheel fit clip board
  - DST-CF5** Fully adjustable driver's comfort seat  
Air suspension, heated, integrated safety belt
  - SBD-RED** Red safety belts, pass. & driver seats
  - SBPRE-DS** Drivers seat belt pretensioner
  - PST-BAS1** Basic passenger's seat
  - PST-BENC** Passenger bench seat
  - PST-CF5** Fully adjustable passenger comfort seat  
Air suspension, heated, safety belt
  - SBPRE-PS** Passenger seatbelt pretensioner
  - ARM-DBPS** Armrests driver's both sides - passenger side single
  - ARMRE-BB** Armrests both sides - driver's & passenger's seat
  - ARMRE-DB** Armrests both sides - driver's seat
  - ARU-BAS** Seat armrest upholstery - basic
  - GRABHI-B** Instep grab handle - standard
  - FMAT-RUB** Floor mats - rubber
  - LBK70** Lower bunk 700mm wide
  - MATL-FI** Mattress lower bunk - firm
  - MATL-SF** Mattress lower bunk - semi firm
  - OLMAT-BA** Mattress overlay - basic
  - SAFE** Safe box at bed-end
  - ETSB-F** Engine tunnel storage box
  - ETSB-FR** Engine tunnel storage box & rear cab wall
  - ETSB-R** Rear cab wall storage
  - REF-ICPK** Refrigerator prep kit (on engine tunnel)
  - BOTH-D** Bottle holder in driving area
  - INLI-BAS** Interior night lights
  - RH-ER** Roof hatch-electric (metal emergency exit)
  - RH-MTR** Roof hatch-manual (tinted glass & rear opening)
  - SWIND-PS** Cab passenger side aux. window
  - AWIND-RF** Cab rear window- fitted
  - VANMIR** Vanity mirror
- ### Cab exterior
- EXTL-BAS** Standard exterior trim level
  - DGLAS-H** Hardened door glass
  - DGLAS-L** Laminated door glass
  - LOCK-CTL** Central door locking-Key
  - LOCK-REM** Central door locking with remote control
  - BUMP-HD** Bumper - heavy duty
  - AUXFS** Auxiliary folding side step
- GUARD-EH** Guard plate for cooling pipes and oil sump
  - BUGNET** Insect net in front of radiator
  - CTILT-P-E** Electrical cab tilt pump
  - FCABS-A** Front cab suspension-air bellows
  - FCABS-M** Front cab suspension-mechanical spring
  - RCABS-A** Rear cab suspension-air bellows
  - RCABS-M** Rear cab suspension-mechanical spring
  - MIRCFCPX** Electrically heated & operated convex glass mirrors with front monitoring camera on passenger side.
  - MIRCOMFX** Electrically heated & operated convex glass mirrors
  - AMIR-F20** Close view mirror
  - SUNV-H** Exterior sunvisor
  - GUARD-W** Windscreen stoneguard
  - HL-BASIC** Standard head lamps
  - HL-CLEAN** Head lamp cleaning system
  - HLP-ST** Headlamp protection-steel
  - HLP-ST2** Headlamp protection-steel/wire mesh (non ADR compliant)
  - DRL-LED** V-shaped LED daytime running light
  - IDLAMP-A** Identification lamps-amber
  - BEACON-P** Beacon light wire preparation
  - SPOTP-F** Aux spotlamp preparation, 280W maximum
  - ANT-CBR** Antenna for CB radio, single antenna
- ### Superstructure
- SRWL-2RW** 2 white rear chassis mounted working lamps
  - SRWL-PK** Wiring prep for chassis mounted reverse/working lamps-3 position switch
  - SWL-2FW** 2 white side working lamps (forward facing)
  - SWL-2RW** 2 white side working lamps (rearward facing)
  - SWL-4W** 4 white side working lamps
  - SWL-PK** Wiring prep for chassis-mounted working lamps-2 position switch
  - WL-CHPK** Chassis mounted working lamp prep kit
  - WLC-H2W** 2 x H3/70W high mounted work lamps with white lens.
  - WLC-PKH** Prep kit for high mounted work lamps.
  - WLC-PKLH** Prep kit for low and high mounted work lamps.
  - ECBB-HIG** Body builder module - cab module
  - BBCHAS3** Body builder chassis electrical interface, 3 x 7 pin connectors
  - BEPR-T2** Body Builder electrical prep. for tipper with remote control
  - HBA-SB** Holes for body attachments
  - AESW2** 2 flexible switches (AUX1 and AUX2).
  - AESW2PK** 2 flexible switches (AUX1 & AUX2) + additional 4 flexible switches
  - AUXSW-4** 4 extra bi-stable switches wired to BBM
- ### Delivery services
- TGW-4GWL** Telematics Gateway with 4G/LTE & WLAN
  - FMS-PK** Fleet management system gateway
  - DRUT2** "My Truck" smartphone app. 2 year prepaid

# VOLVO

Volvo Truck Corporation  
volvotrucks.com