

MODEL RANGE

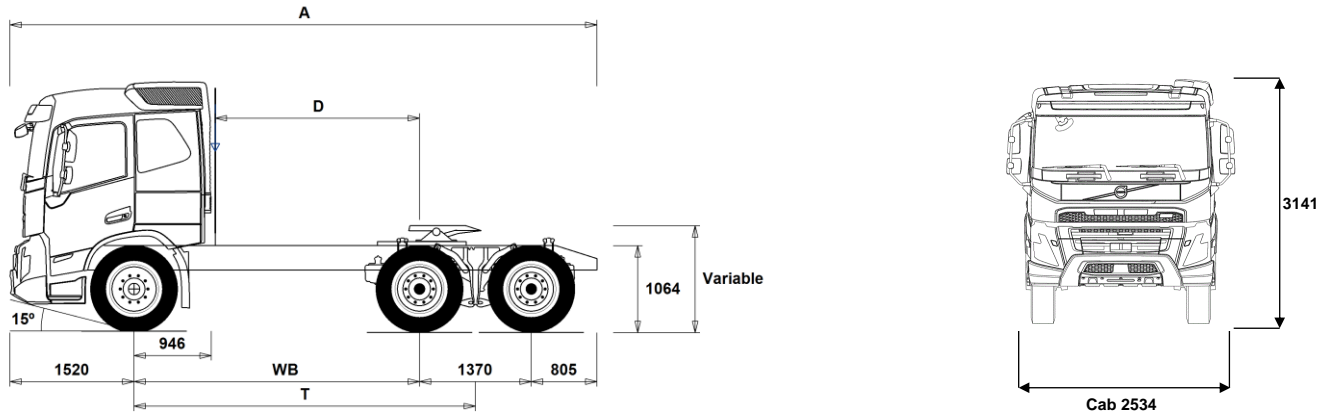

Volvo Trucks. Driving Progress

NEW FMX11 6x4 Tractor - Rear Air Suspension - N3 or N3G FMX 64T 1A



Chassis Dimensions [mm]

WB Wheelbase	3000	3200	3400	3600	3900
A Overall Chassis Length	6695	6895	7095	7295	7595
D Center of rear axle to back of cab	2004	2204	2404	2604	2904
T Theoretical Wheelbase	3685	3885	4085	4285	4585

Chassis Weights [kg]

Front Axle	4710	4720	4740	4755	4770
Rear Bogie	3610	3615	3620	3625	3630
Kerb Weight	8320	8335	8360	8380	8400

Turning Diameter [mm]

Turning Circle Diameter Kerb to Kerb	13300	13900	14500	15100	16100
Turning Circle Diameter Wall to Wall	14800	15400	16000	16600	17600

Plated Weights [kg]

	Plated	Design
Gross Vehicle Weight	26000	28500
Gross Combination Weight	44000	44000
Front Axle	7500	7500
Rear Bogie	19000	21000

Important Notes

Chassis Dimensions

Cab Height: -16 mm for CAB-DAY, +312 mm for CAB-HSLP, -278 mm for CAB-LDAY, -278 mm for CAB-LSLP.

Front Axle to Back of Cab: -431 mm for CAB-DAY, -500 mm for CAB-LDAY, -6 mm for CAB-LSLP.

D-measure includes a front clearance of 50 mm and for rigid trucks also a subframe of 100 mm.

Height can vary ± 20 mm for leaf and ± 10 mm for air suspension.

All dimensions are for unladen chassis and any tag axles down. Chassis height used: CHH-XHIG.

Weight and dimensions are based upon the following tyres:

Front Axle Tyres: 315/80R22.5
Drive Axle Tyres: 315/80R22.5

Chassis weight includes oil, water, AdBlue, 0 litres fuel and without driver. Kerb weight can vary $\pm 3\%$.

Turning diameters are theoretically calculated.

Legal weights can differ from country to country.

For more detailed weight information, including optional equipment weights, ask your Volvo sales contact to enter your specification into the Volvo Weight Information system (WIS).

Do NOT use this drawing for bodybuilding. Refer to Volvo Bodybuilder Instructions and chassis assembly drawing FMX64T1A.

MODEL RANGE

NEW FMX11 6x4 Tractor - Rear Air Suspension - N3 or N3G FMX 64T 1A

TRUCK USE

- RC-ROUGH** Road conditions - On / off-road
- RC-SMOOTH** Road Conditions - Smooth

CORE COMPONENTS

- **CHH-XHIG** Chassis Height - X-High - for loading heights check the unique BEP chassis drawing
- **RADD-G2** Rear air suspension, 2 axles - 2 driven, high ground clearance
- FMX-DAY5** Cab - Day - with steel safety cage design
Designed and built to Swedish impact and ECE R29 regulations
- FMX-HSL5** Cab - Globetrotter - with steel safety cage design
Designed and built to Swedish impact and ECE R29 regulations
- FMX-LDA5** Cab - Low Day - with steel safety cage design
Designed and built to Swedish impact and ECE R29 regulations
- FMX-LSL5** Cab - Low Sleeper - all-steel safety cage design.
Built to Swedish impact and ECE R29 regulations
- **FMX-SLP5** Cab - Sleeper - with steel safety cage design
Designed and built to Swedish impact and ECE R29 regulations
- **EU6SCR** Emission level - Euro VI step E
- **D11K330** Engine - D11K330 10.8 litre engine developing 330hp at 16-1900rpm.
Peak torque 1600Nm at 950-1400rpm.
- D11K380** Engine - D11K380 10.8 litre engine developing 380hp at 17-1900rpm.
Peak torque 1800Nm at 950-1400rpm.
- D11K430** D11K430 10.8 litre engine developing 430hp at 17-1800rpm.
Peak torque 2050Nm at 1058-1400rpm.
- D11K460** D11K460 10.8 litre engine developing 460hp at 16-1800rpm.
Peak torque 2200Nm at 1050-1400rpm.
- EBR-EPG** Engine Brake Type - Exhaust brake controlled by steering column switch
- EBR-EPGC** Engine Brake Type - Exhaust pressure governor for I shift gearbox
- EBR-VEB** Engine Brake Type - Volvo engine brake and exhaust pressure governor retardation 300kW
- **AT2612F** Gearbox - AT2612F 12-speed "I-shift" automated mechanical suitable for gross train weights up to 60tonne only.
Refer to sales engineering when used in conjunction with a PTO
- ATO2612F** Gearbox - ATO2612F 12-speed "I-shift" overdrive automated mechanical, suitable for gross train weights up to 60tonne.
Refer to sales engineering when used in conjunction with a PTO
- PT2106** Gearbox - Powertronic automatic 6-speed, max. engine torque 2100 Nm, max. permitted GCW 100000 kg
- TAAXLIFT** Rear axle lift for double drive bogie
CONTACT VOLVO SALES ENGINEERING to check lift capability
- RTH2610B** Drive Axles - RTH2610B 26-tonne hub reduction tandem with differential and cross locks* - design GCW 100tonne, 4 planetary gears
* Cross locks replaced by a dog clutch if tandem axle lift is specified.
- RTH2610F** Drive Axles - RTH2610F 26-tonne hub reduction tandem with differential and cross locks* - design GCW 100tonne
* Cross locks replaced by a dog clutch if tandem axle lift is specified.
- RTS2310A** Drive Axles - RTS2310A 23-tonne single reduction tandem with differential and cross locks*- design GCW 100tonne
* Cross locks replaced by a dog clutch if tandem axle lift is specified
- **RTS2370A** Drive Axles - RTS2370A 23-tonne single reduction tandem with differential and cross locks*- design GCW 70tonne
* Cross locks replaced by a dog clutch if tandem axle lift is specified

PACKAGES

- Standard Equipment
- Optional Equipment

For more detailed information about cab and powertrain equipment, please refer to separate specification sheets.

For all possible options and combinations of options please consult your Volvo sales contact who can create a specification to match your requirements using the Volvo Sales Support system (VSS).

The factory reserves the right to modify design and change equipment without previous notification. The specification can vary from country to country.

- FUELPACK** Long Haul Fuel Economy driving package
 - AIRFLOW** Air flow package including roof and side air deflectors plus chassis skirts
 - DRIVE5** Drive Package
 - DRIVE5+** Drive+ Package
 - DRIVE5++** Drive++ Package
 - 1LIVINFM** Sleep & Resting Package - Living one-bed
 - 2LIVINFM** Sleep & Resting Package - Living two-bed
 - INFOBAS** Basic media package without secondary display
 - INFODF** Media Information Platform with Dynafleet Support
 - INFOMED** Media Information Platform - Medium level
 - INFONAV** Media Information Platform with Navigation
 - INFONDF** Media Information Platform with Navigation & Dynafleet Support
 - VISIX5** Visibility Package
 - SAFE-VE** Active Safety Package
 - SAFE-VE+** Active Safety+ Package
- ### CHASSIS
- FST-AIR** Front suspension type - Air
 - **FST-PAR** Front suspension type - 2 leaf parabolic springs
 - FST-PAR3** Front suspension type - 3 leaf parabolic springs
 - FSL5-BAS** Front suspension levelling - basic stroke
 - FSL5-HI** Front suspension levelling - high stroke for demount operations - check with bodybuilder
 - FAL10.0** Front axle design capacity - 10 tonne - check tyre capacity
 - **FAL7.5** Front axle design capacity - 7.5 tonne
 - FAL8.0** Front axle design capacity - 8.0 tonne - check tyre capacity
 - FAL8.5** Front axle design capacity - 8.5 tonnes
 - FAL9.0** Front axle design capacity - 9.0 tonne - check tyre capacity
 - FSM-LUB** Front suspension maintenance - Lubricated rear shackles on pins and bushings
 - **FSTAB** Front anti-roll bar - Normal stiffness
 - FSTAB2** Front anti-roll bar - Medium stiffness
 - FSTAB3** Front anti-roll bar - High stiffness
 - **RAL21** Rear bogie design capacity - 21 tonne
 - RAL23** Rear bogie design capacity - 23 tonne
 - RAL26** Rear bogie design capacity - 26 tonne
 - **RSTAB1** Rear anti-roll bar - Normal stiffness
 - RSTAB3** Rear anti-roll bar - Stiff
 - RALIM105** Rear-axle load limiter - 10.5 tonne - speed controlled
 - **RALIM115** Rear-axle load limiter - 11.5 tonne - speed controlled
 - RALIM13** Rear-axle load limiter - 13 tonne
 - RALIM95** Rear-axle load limiter - 9.5 tonne
 - **ASF-DL1** Air suspension with 1 driving level
 - ASF-DL3** Air suspension with 3 driving levels
 - ACTST-TO** Active Steering- Volvo Dynamic Steering - VDS - with extra electronic pump and torque overlay
 - ASFE-BAS** Active steering feature - Basic - Volvo Dynamic Steering - VDS - only
 - ASFE-OG** Active steering feature - Volvo Dynamic Steering - VDS - with stability assist - oversteer
 - ASFE-PO** Active steering feature - Volvo Dynamic Steering - VDS - with personal settings and stability assist
 - ASFE-PS** Active steering feature - Volvo Dynamic Steering - VDS - with personal settings
 - **PSS-SING** Power steering system - Single
 - **PSP-FIX** Power steering pump - Fixed displacement
 - PSP-VAR** Power steering pump - Variable displacement
 - **EBS-MED** Brake package - EBS medium including "hill" hold function
 - AUXPARK** Auxiliary parking brake - Additional spring brakes
 - **FRAME300** Chassis frame section external height - 300 mm

MODEL RANGE

NEW FMX11 6x4 Tractor - Rear Air Suspension - N3 or N3G FMX 64T 1A

- FST7070** Chassis frame thickness - 7 mm web and flange
- FST8080** Chassis frame thickness - 8 mm web and flange
- FIL-EEEB** Chassis frame inner liner - From the end of the engine to the end of the bogie
- FIL-TXEB** Chassis frame inner liner - From gearbox member to the end of the bogie
- BBOX-EF** Battery box position - End of the frame in rear overhang
- BBOX-L** Battery box position - Left hand side
- 2BAT210B** Battery Capacity - 2 x 210 Ah - Gel type
- 2BAT210C** Battery Capacity - 2 x 210 Ah - AGM Absorbent Glass-fibre Material type
- BATTAMP** Battery management - Voltage and current gauge
- BATTIND** Battery management - Charge indicator
- ADR2** ADR Adaptation - For transportation of dangerous goods on the road - Note does NOT include safe loading pass package if required this is quoted separately
- MSWI-A** Battery master switch - ADR switch circuit shut down
- MSWI-C** Battery master switch - Chassis mounted toggle by the battery box
- MSWI-R** Battery master switch - Key fob operated remote controlled
- R330A71** Right fuel tank - 330litre aluminium diameter 710mm
Min volume 150l
Max volume 810l
- UL-FUEL** Without left fuel tank
Min volume 160l
Max volume 620l
- ADTP-BC** AdBlue tank position - Behind and under the cab on the right-hand side
- ADTP-L** AdBlue tank position - Chassis mounted on the left-hand side
- ADTP-R** AdBlue tank position - Chassis mounted on the right-hand side
- ADB048** Plastic AdBlue tank - 48 litre
- ADB050** Plastic AdBlue tank - 50 litre under/behind the cab
- ADB064** Plastic AdBlue tank - 64 litre
- ADB068** Plastic AdBlue tank - 68 litre
- ADB090** Plastic AdBlue tank - 90 litre
- ADB100** Plastic AdBlue tank - 100 litre
- ADTC-BF** AdBlue tank cover with satin alloy look decorative cover
- FCAP-L** Diesel and AdBlue filler cap - Locking
- FUFF-AS** Fuel filler - Anti-spill device
- FUFF-ATS** Fuel filler - Anti-spill & anti-syphon device
- ESH-LEFT** Exhaust - Horizontal silencer - left outlet
- ESH-REAR** Exhaust - Horizontal silencer - rear outlet
- ESH-RIGH** Exhaust - Horizontal silencer - right outlet
- ESH-VERT** Exhaust - Horizontal silencer - vertical outlet
- EXST-SSP** Stainless steel exhaust stack - NOT polished
- EXST-ST** Steel exhaust stack
- WHC-FIX2** Wheel chocks - Two fixed design
- WHC-FOL2** Two foldable wheel chocks
- WHCP-F** Wheel chock carrier position - In the front part of the vehicle
- WHCP-M** Wheel chock carrier position - Middle part of the vehicle
- WHCP-T** Wheel chock carrier position - Outer luggage locker
- TB-L80** Toolbox 800 mm, left side
- TB-R80** Toolbox 800 mm, right side
- SUP-BAS** EC approved chassis side guards
- SUP-LOW** EC approved low chassis side guards
- CHAIN-S** Snow chains
- HOOK-SC** Snow chain hooks
- TOWF-HD1** Front towing device - One heavy-duty front towing device
- RFEC-B** Rear frame profile - Tapered
- TOWR-ONE** Towing hitch attached to rear crossmember
- TREL15** Trailer electrical connection - Single 15 pin - ADR certified
- TREL7** 7 pole - 24N trailer electrical suzie
- TREL7-7** Trailer electrical connection - 2 x 7 pin - 24N and 24S
- TBC-DUO** Duomatic type air line connectors
- TBC-EC** Trailer brakes with EC palm coupling connectors
- TBC-GBR** 'C' and 'CA' type air line connectors
- TRBR-HCF** Full pressure hand controlled trailer brake
- TRBR-STA** Stationary trailer brake control
- TRB-STRE** Stretch Brake - Automatic low speed trailer brake activation to avoid jack-knifing and improve steerability
- RFEND-B** Three piece EC approved rear mud wings and spray flaps
- RFH-BAS** Basic rear wing height
- RFH-HIG** High rear wing height - higher wing tops
- RFH-LOW** Lower rear wing height - shallower wing tops
- ATANK-AL** Air tanks - Aluminium
- ATANK-ST** Air tanks - Steel
- TL-LED** Rear lights - LED
- BLIGHT-E** Emergency brake light

WHEELS & TYRES

- RT-AL** Wheels - Alcoa brushed aluminium rims - standard holes for long stud fixing
- RT-ALDP** Wheels - Alcoa Dura-Bright aluminium rims - standard holes for long stud fixing
- RT-ALDPD** Wheels - Alcoa Dura-Bright EVO aluminium rims - countersunk holes for short stud fixing
- RT-ALDU** Wheels - Alcoa brushed aluminium rims - countersunk holes for short stud fixing
- RT-SPOKE** Spoke rims on all axles
- RT-STEEL** Wheels - Steel rims
- WCAP** Aerodynamic hub caps
- SPWT-D** Spare wheel & tyre with rear tyre pattern
- SPWT-F** Spare wheel & tyre with front tyre pattern
- SWCP-LF** Spare wheel carrier on left side of chassis ahead of rear axle
- SWCP-T** Spare wheel supplied temporarily strapped to chassis
- SWCP-TP** Temporary spare wheel carrier on top of chassis frame
- JACK-12T** 12 tonne bottle jack
- JACK-15T** 15 tonne bottle jack
- JACK-20T** 20 tonne bottle jack
- TOOL-BAS** Basic Toolkit
- TOOLKIT** Complete tool kit
- INFLAHOS** Tyre inflation hose
- GAUGE-TP** Tyre pressure gauge

DRIVELINE EQUIPMENT

- TRAP-HD** Reinforced gearbox application
- DRM-BE** Balanced & Economy Drive Mode
- DRM-E** Economy Drive Mode
- PVT-MAP** I-See Predictive Cruise Control - using map based topography information
- CRUIS-E** Eco cruise control (with eco-roll and I-cruise, controls in steering wheel)
- CRUIS-E4** Eco fleet software - with cruise speed 85, I-See and push button I-shift.
- CRUIS-E5** Eco torque software - Improved economy mode. Fuel economy optimized cruise control for I-Save
- CRUISEC** Cruise control, standard
- AMSO-AUT** Enhanced I-shift software with manual shift available in auto mode and kickdown facility on accelerator pedal
- AVO-ENH** I-Shift application software - for construction and off road applications
- APF-ENH** I-shift enhanced PTO functions

Standard Equipment

Optional Equipment

For more detailed information about cab and powertrain equipment, please refer to separate specification sheets.

For all possible options and combinations of options please consult your Volvo sales contact who can create a specification to match your requirements using the Volvo Sales Support system (VSS).

The factory reserves the right to modify design and change equipment without previous notification. The specification can vary from country to country.

MODEL RANGE

NEW FMX11 6x4 Tractor - Rear Air Suspension - N3 or N3G FMX 64T 1A

<input type="checkbox"/> RET-TH	Gearbox mounted retarder	<input type="checkbox"/> PTRD-D2	Gearbox driven HIGH SPEED PTO (2 SAE flanges & 1 plug-in hyd pump)
<input type="checkbox"/> RET-TPT	Hydraulic Retarder for Powertronic gearbox	<input type="checkbox"/> PTRD-F	PTO with 1 DIN + 1 flange connection rear, manual gearbox
<input type="checkbox"/> TC-HWO	Transmission oil cooler - water to oil	<input type="checkbox"/> HPG-F101	Parker F1-101 gearbox mounted, fixed displacement, single flow, hydraulic pump
<input type="checkbox"/> TC-MAOH2	Extra high performance transmission oil cooler - air to oil with front mounted radiator	<input type="checkbox"/> HPG-F41	Parker F1-41 gearbox mounted, fixed displacement, single flow, hydraulic pump
<input type="checkbox"/> TC-MWO	Basic transmission oil cooler - water to oil	<input type="checkbox"/> HPG-F51	Parker F1-51 gearbox mounted, fixed displacement, single flow, hydraulic pump
<input type="checkbox"/> 2COM1100	Air compressor - Two-cylinder 1100 litres per minute	<input type="checkbox"/> HPG-F61	Parker F1-61 gearbox mounted, fixed displacement, single flow, hydraulic pump
<input checked="" type="checkbox"/> 2COMP900	Air compressor - Two-cylinder 900 litres per minute	<input type="checkbox"/> HPG-F81	Parker F1-81 gearbox mounted, fixed displacement, single flow, hydraulic pump
<input type="checkbox"/> CLU-AIRC	Clutchable air compressor	<input checked="" type="checkbox"/> STWPOS-R	Steering wheel position - RIGHT-HAND DRIVE
<input checked="" type="checkbox"/> AIRIN-HI	Air intake - Roof-mounted behind cab on the left-hand side	<input type="checkbox"/> STWM-LE	Leather steering wheel
<input type="checkbox"/> AIRIN-LO	Low level air intake behind cab on left hand side	<input type="checkbox"/> STGW-AD2	Adjustable steering wheel with neck tilt
<input type="checkbox"/> ACL1ST-S	Air filter - two-stage element	<input checked="" type="checkbox"/> STGW-ADJ	Adjustable steering wheel
<input checked="" type="checkbox"/> 24AL110B	Alternator capacity - 110 amp	<input checked="" type="checkbox"/> AIRBAG	SRS Driver's air bag
<input type="checkbox"/> 24AL120B	Alternator capacity - 120 amp alternator	<input type="checkbox"/> INST-BAS	Basic level instruments
<input type="checkbox"/> 24AL150B	Alternator capacity - 150 amp	<input checked="" type="checkbox"/> DRC-AMII	DPF Regeneration control switch - for manual and switching off regeneration
<input type="checkbox"/> CCV-C	Closed crankcase engine ventilation	<input checked="" type="checkbox"/> 1DAYDIG2	Tachograph - Continental VDO 4.0
<input checked="" type="checkbox"/> CCV-OX	Closed crankcase ventilation for cold markets	<input type="checkbox"/> ARSL	Additional road speed limit - switch in dashboard
<input checked="" type="checkbox"/> PRIM-EL	Electrical priming pump	<input checked="" type="checkbox"/> ESP-BAS1	Electronic Stability Control
<input type="checkbox"/> PRIM-MAN	Manual priming pump	<input type="checkbox"/> ESPC-RO	ESP (Electronic Stability Program) functionality control - Reduced / Off
<input type="checkbox"/> FUEQ-EH	Fuel line electric heater	<input type="checkbox"/> HWSS-ACB	Adaptive cruise control ACC with forward collision warning and AEBS advanced emergency brake system
<input type="checkbox"/> AF-R	Hot fuel recirculation heated fuel filter	<input type="checkbox"/> HWSS-FCB	Forward collision warning with AEBS advanced emergency brake system
<input checked="" type="checkbox"/> FUEFE2SW	Small engine mounted dual fuel filter with water separator	<input type="checkbox"/> LSS-DW	Lane departure-warning system
<input type="checkbox"/> EST-AID	Engine starting aid -Preheating element in the air inlet manifold	<input type="checkbox"/> LCS	Lane change support
<input type="checkbox"/> 220EBH15	220V/1.5Kw electric engine block heater	<input type="checkbox"/> DAS-W	Driver Alert Support system
<input type="checkbox"/> PTER-100	Engine power-take-off - Rear-mounted with DIN100/ISO7646 flange	<input type="checkbox"/> RSENS-W	Rain sensing windscreen wipers
<input type="checkbox"/> PTER-DIN	Engine power-take-off - Rear-mounted with DIN5462 (female) splined shaft for a close-coupled pump Models with 3 steering axles will use this to drive the steering pump (AUXPSP)	<input type="checkbox"/> CU-ECC	Cab Climate Unit - Electrically controlled air conditioning with sun sensor
<input type="checkbox"/> PTER1400	Engine power-take-off - Rear-mounted with SAE 1410 flange	<input type="checkbox"/> CU-ECC2	Cab Climate Unit - Electrically controlled air conditioning with a carbon filter, sun, mist, and air quality sensor
<input type="checkbox"/> HPE-F101	Parker F1-101, engine mounted, fixed displacement, single flow, engine mounted hydraulic pump	<input checked="" type="checkbox"/> CU-MCC	Cab Climate Unit - Manual air conditioning
<input type="checkbox"/> HPE-F41	Parker F1-41, engine mounted, fixed displacement, single flow, engine mounted hydraulic pump	<input checked="" type="checkbox"/> IMMOBIL	Thatcham H2 approved immobiliser
<input type="checkbox"/> HPE-F51	Parker F1-51, engine mounted, fixed displacement, single flow, engine mounted hydraulic pump	<input type="checkbox"/> ALARM-E	Enhanced vehicle alarm - Thatcham H1 approved - Cab plus external sensor for body/trailer
<input type="checkbox"/> HPE-F61	Parker F1-61, engine mounted, fixed displacement, single flow, engine mounted hydraulic pump	<input type="checkbox"/> ALCOLOCK	Alcolock
<input type="checkbox"/> HPE-F81	Parker F1-81, engine mounted, fixed displacement, single flow, engine mounted hydraulic pump	<input type="checkbox"/> BUPMON	Back up monitor - Digital reverse camera, parameter & lead supplied loose in cab.
<input type="checkbox"/> HPE-T53	Parker F2-53/53, engine mounted, Fixed displacement, Twin flow engine mounted hydraulic pump	<input type="checkbox"/> PHONE-PK	Telephone preparation kit (antenna, antenna attachm. cable incl.)
<input type="checkbox"/> HPE-T70	Parker F2-70/35, engine mounted, Fixed displacement, Twin flow engine mounted hydraulic pump	<input checked="" type="checkbox"/> ISUNS-BS	Side sun visor - Driver & passenger side
<input type="checkbox"/> HPE-V45	Parker VP1-45, variable displacement, single flow, engine mounted hydraulic pump	<input checked="" type="checkbox"/> ISUNS-DS	Side sun visor - Driver-side
<input type="checkbox"/> HPE-V75	Parker VP1-75, variable displacement, single flow, engine mounted hydraulic pump	<input type="checkbox"/> ISUNF-B	Interior front sun visor without mirror
<input type="checkbox"/> PTPT-D	Powertronic PTO, 1 front/upper DIN connection for plug-in pump (max. 850 Nm)	<input type="checkbox"/> ISUNF-MD	Interior front sun visor with mirror on driver side
<input type="checkbox"/> PTPT-F	Powertronic PTO, 1 front/upper rear facing SAE flange conn. for prop shaft (max.850 Nm)	<input type="checkbox"/> ISUNF-RE	Electrically operated textile interior sun blind
<input type="checkbox"/> PTR-D	Gearbox PTO for plug-in pump, 0.71xeng speed	<input checked="" type="checkbox"/> ISUNF-RM	Manually operated textile interior sun blind
<input type="checkbox"/> PTR-DH	Gearbox driven high speed PTO for one plug-in hydraulic pump	<input type="checkbox"/> ADFS	Two extra DIN slots in front shelf - can be fitted with card or drawer available as an accessory
<input type="checkbox"/> PTR-DM	Gearbox driven medium speed PTO for one plug-in hydraulic pump	<input checked="" type="checkbox"/> BUPALARM	Reverse alarm
<input type="checkbox"/> PTR-F	Gearbox driven PTO with rear flange connection	<input type="checkbox"/> RTOLL-PK	Road toll PREPARATION kit for trucks operating with "Toll Collect" in Germany
<input type="checkbox"/> PTR-FH	Gearbox driven high speed PTO with SAE drive flange	<input type="checkbox"/> LOADIND	Load indicator with central dashboard display
<input type="checkbox"/> PTR-FL	Gearbox driven low speed PTO with SAE drive flange		
<input type="checkbox"/> PTRD-D	Gearbox driven HIGH SPEED PTO for two plug-in hydraulic pumps		
<input type="checkbox"/> PTRD-D1	PTRD-D1 Gearbox driven HIGH SPEED PTO (1 SAE flange & 1 plug-in hydraulic pump)		

■ Standard Equipment

□ Optional Equipment

For more detailed information about cab and powertrain equipment, please refer to separate specification sheets.

For all possible options and combinations of options please consult your Volvo sales contact who can create a specification to match your requirements using the Volvo Sales Support system (VSS).

The factory reserves the right to modify design and change equipment without previous notification. The specification can vary from country to country.

MODEL RANGE

NEW FMX11 6x4 Tractor - Rear Air Suspension - N3 or N3G FMX 64T 1A

- | | |
|---|---|
| <ul style="list-style-type: none"> <input type="checkbox"/> REMC-MF Multi-functio wireless remote control <input type="checkbox"/> FIREXT3S Fire extinguisher - 3kg mounted on the seat base <input type="checkbox"/> WARNVEST High visibility warning vest - no sleeves <input type="checkbox"/> AIDKIT First aid kit - Legal demand for EU markets including delivery to EU bodybuilder <input type="checkbox"/> AIDKIT1B First aid kit - Legal demand for trucks transiting Germany <input type="checkbox"/> WARNLAMP Portable warning lamp <input type="checkbox"/> LAMP-IN Inspection lamp <input type="checkbox"/> BULBKIT Bulb and fuse kit <input type="checkbox"/> WRITEPAD Writing pad ■ DST-CF4 Driver seat - Suspended, adjustable shock absorber, travel, backrest & lumbar controls - seatbelt mounted to the seat <input type="checkbox"/> DST-CF5 Driver seat - Suspended with adjustable shock absorber, travel, backrest, lumbar & heat controls - seatbelt mounted to the seat <input type="checkbox"/> DST-CF6 Driver seat - Suspended with adjustable shock absorber, travel, backrest, lumbar, heat and ventilation controls - seatbelt mounted to the seat <input type="checkbox"/> SBD-RED Seat belt colour - Red <input type="checkbox"/> SBPRE-DS Driver seat belt pretensioner ■ PST-BAS1 Passenger seat - Fixed non suspended fold up with seatbelt mounted in cab <input type="checkbox"/> PST-CF4 Passenger seat - Suspended, adjustable shock absorber, travel, backrest & lumbar controls - seatbelt mounted to the seat <input type="checkbox"/> PST-CF5 Passenger seat - Suspended with adjustable shock absorber, travel, backrest, lumbar & heat controls - seatbelt mounted to the seat <input type="checkbox"/> PST-STD2 Passenger seat - Fixed with backrest adjustment, non suspended with seatbelt mounted in cab <input type="checkbox"/> PST-STD4 Passenger seat - Standard suspended with seatbelt mounted in cab <input type="checkbox"/> SBPRE-PS Passenger seat belt pretensioner <input type="checkbox"/> ARMRE-BB Armrests - Two on both driver & passenger seats <input type="checkbox"/> ARMRE-DB Armrests - Two on the driver seat <input type="checkbox"/> ARMRE-PB Armrests - Two on the passenger seat <input type="checkbox"/> ARU-BAS Armrest upholstery - Vinyl <input type="checkbox"/> ARU-LEA Armrest upholstery - Leather ■ FMAT-RUB Footwell floor mats - Rubber <input type="checkbox"/> FMAT-TX2 Footwell floor mats - Two sets, Rubber and textile with an embossed pile supplied in the cab ■ LBK70 Lower bunk 700 x2000 mm, fixed <input type="checkbox"/> MATL-FI Firm lower bunk pocket sprung mattress ■ MATL-SF Lower flexizone mattress - semi-firm, pocket springs up to 100kg - 16 stone <input type="checkbox"/> OLMAT-BA 35mm premium overlay protector <input type="checkbox"/> OLMAT-PR 50mm premium mattress overlay protector <input type="checkbox"/> TBK60F Fixed foldable top bunk 600 x 1900mm <input type="checkbox"/> TBK70F Fixed foldable top bunk 700 x 1900mm <input type="checkbox"/> PH-CAB2 1.8kW Air to air night heater <input type="checkbox"/> PH-ENGCA Engine and cab night heater <input type="checkbox"/> PH-SS Short stop heater <input type="checkbox"/> SLCP-BAS Sleeper control panel - Basic with switches for interior light, night heater, roof hatch and door lock <input type="checkbox"/> ETSB-F Storage on engine tunnel - Central document box with two rear cup holders <input type="checkbox"/> ETSB-FR Storage on engine tunnel - Central document box with two rear cup holders & open storage pocket on cab rear wall <input type="checkbox"/> ETSB-R Storage on engine tunnel - Open storage pocket on cab rear wall <input type="checkbox"/> RUS-BAS Rear cab upper storage - 300 mm high | <ul style="list-style-type: none"> <input type="checkbox"/> RUS-HIG Rear cab upper storage - 440 mm high - volume 245 litres <input type="checkbox"/> REF-ICPK Fridge: engine tunnel mounted preparation kit <input type="checkbox"/> REFR-RUS Fridge - 28 litre rear upper wall mounted with dividers <input type="checkbox"/> MICRO-PK Wiring preparation kit for microwave oven <input type="checkbox"/> BOTH-D One bottle holder under dashboard centre section <input type="checkbox"/> COFMA-PK Coffee maker, preparation kit. ■ INLI-BAS Interior white LED lights - basic <input type="checkbox"/> INLI-NL Interior white and red night LED light with no dimmer <input type="checkbox"/> INLI-NLD Interior white and red night LED light with dimmer <input type="checkbox"/> ARL-FLEX Two flexible reading lamps (snake lamps) ■ RH-EE Fixed tinted glass sky window with emergency exit <input type="checkbox"/> RH-ER Steel roof hatch - Electrically operated, rear opening with emergency exit <input type="checkbox"/> RH-ETR Tinted glass roof hatch - Electrically operated, rear opening with emergency exit <input type="checkbox"/> RH-MTR Tinted glass roof hatch - Manually operated, rear opening with emergency exit ■ GLAS-TIN Tinted windows. <input type="checkbox"/> SWIND-BS Extra side window on both sides behind "B" pillar <input type="checkbox"/> SWIND-PS Cab side window - Left side rear behind 'B' post <input type="checkbox"/> AWIND-RF Rear window <input type="checkbox"/> VANMIR Vanity mirror in front shelf <input type="checkbox"/> AS-FUS Extra shelf in front upper storage compartments <input type="checkbox"/> INFOT-PK Preparation kit for the mounting of a flat screen TV in cab above the driver's door, includes bracket, electrical and speaker connections |
|---|---|
-
- Standard Equipment
 - Optional Equipment

■ **EXTL-BAS** Basic exterior finish - Satin Volvo badges, grey grille, instep, bumper, bumper spoiler, grille, door handles mirror housing and sunvisor if specified.

■ **DGLAS-H** Tempered door glass

DGLAS-L Laminated door glass

■ **LOCK-CTL** Door locks - Central locking with key

LOCK-REM Door locks - Remote central locking

■ **BUMP-HD** Heavy duty front bumper

AUXFS Lower swinging cab step

GUARD-EH Engine guard to protect sump and engine hoses

■ **BUGNET** Insect screen in front of radiator

CTILT-P-E Electrically operated hydraulic cab tilt

■ **CTILT-P-M** Manually operated hydraulic cab tilt

FCABS-A Front cab suspension - Air

■ **FCABS-M** Front cab suspension - Mechanical spring

RCABS-A Rear cab suspension - Air

■ **RCABS-M** Rear cab suspension - Mechanical spring

MIRFCPX Mirrors - Electrically heated and operated - FMX- main and wide-angle with manually adjusted kerb view mirror on the passenger side and position camera in nearside mirror arm. To increase direct vision to the side the main mirrors have no cowlings

MIRCOMFX Electrically heated and operated -FMX- main and wide-angle mirrors with manually adjusted passenger kerb mirror, to increase direct vision to the side the main mirrors have no cowlings

■ **MIRSTDX2** Electrically heated -FMX- main and wide-angle mirrors with manually adjusted passenger kerb mirror, to increase direct vision to the side the main mirrors have no cowlings

■ **AMIR-F20** Auxiliary front view mirror with a 200mm radius

SUNV-H External smoke grey sunvisor

AD-ROOF Roof air deflector

For more detailed information about cab and powertrain equipment, please refer to separate specification sheets.

For all possible options and combinations of options please consult your Volvo sales contact who can create a specification to match your requirements using the Volvo Sales Support system (VSS).

The factory reserves the right to modify design and change equipment without previous notification. The specification can vary from country to country.

MODEL RANGE

NEW FMX11 6x4 Tractor - Rear Air Suspension - N3 or N3G FMX 64T 1A

- AD-SIDEL** Side air deflector extension panels
 - AD-SIDES** Short cab side air deflector for rigid bodywork
 - AD-CHASX** Chassis side skirts
 - ADCF-F** Additional black edging on chassis side skirt
 - HL-BASIC** Halogen H7 head lamps
 - HL-CLEAN** Head lamp cleaner - washer jets
 - HLP-ST** Headlamp protection
 - HL-ADJ** Headlight adjustment - Switch in cab
 - UDRIVL** Without auxiliary driving lights
 - ASL-RF2** Two Hella H11 70W spotlamps in sign box - only available with the basic headlight and no lower driving lights.
 - BEACOA2F** Roof beacons - Two front roof mounted amber LED
 - BEACOA2R** Roof beacons - Two rear roof mounted amber LED
 - BEACON-P** Roof beacons - wiring preparation only
 - BEACONA4** Roof beacons - Four amber LED - two front/ two rear
 - CABPT-R1** Single outlet for roof mounted accessories
 - CABPT-R2** Twin outlets for roof mounted accessories.
 - SPOTP-F** Spotlamp preparation in front, max 280W
 - SPOTP-R** Spotlamp preparation on roof, max 280W
 - SPOTP-RF** Spotlamp preparation on cab roof and in cab front, max 2x280W
 - ROS-IL2** Preparation kit for illuminated roof sign with switch loose in cab, fit after registration
 - CSGN-FMX** "Volvo FMX" headboard logo
 - HORN-F1S** Horn - Air single tone - chassis mounted
 - HORN-R2S** Horn - Air - Two roof-mounted
 - ANT-CBR** Roof mounted antenna for CB radio, single aerial. Only Globetrotter cabs brings in extra DIN slots.
 - ACCB-R-AP** Front, middle & rear roof mounted accessory brackets
 - ACCB-R-F** Front roof mounted accessory bracket
 - ACCB-R-FM** Front & middle roof mounted accessory brackets
 - ACCB-R-FR** Front & rear roof mounted accessory brackets
 - ACCB-R-M** Middle roof mounted accessory bracket
 - ACCB-R-R** Rear roof mounted accessory bracket
 - ACCB-R-RM** Rear & middle roof mounted accessory brackets
 - LADDER** Ladder back of cab
 - REFS-TW** White cab conspicuity markings by packed in cab
 - REFS-TY** Yellow cab conspicuity markings by packed in cab
- ### SUPERSTRUCTURE PREPARATIONS
- 5WM-ISHD** Mount - Heavy-duty 80mm Z profiles with 16mm ISO plate - 96mm high above chassis frame
 - 5WM-ISOM** Mount - 50mm L profiles with 10mm ISO plate - 60mm high above chassis frame
 - 5WM-MASM** Mount - Manual slider with 50mm L profiles
 - 5WH150** Leg-height - 150 mm
 - 5WH185** Leg-height - 185 mm
 - 5WH190** Leg-height - 190 mm
 - 5WH290** Leg-height - 290 mm
 - 5WT-JO11** Fifth wheel - Jost JSK 38G cast heavy-duty
 - 5WT-JO8** Fifth wheel - Jost JSK 37 cast
 - 5WT-JO9** Fifth wheel - Jost JSK 42 cast
 - 5WT-JOHD** Fifth wheel - Jost JSK 38C heavy-duty cast
 - 5WT-SH** Fifth wheel - SAF-Holland/+GF+ SK-S 36.20 cast
 - 5WT-SH2** Fifth wheel - SAF-Holland/+GF+ SK-HD 38.36 cast heavy-duty
 - 5WL-S1** Fifthwheel lubrication - locking mechanism and top plate
 - TCIND** Trailer connection indicator - Sensors for height, kingpin and coupling lock
 - RDECK** Catwalk - Single plate and step
 - RDECK-M** Catwalk - Extended with two plates and step

■ Standard Equipment

□ Optional Equipment

For more detailed information about cab and powertrain equipment, please refer to separate specification sheets.

For all possible options and combinations of options please consult your Volvo sales contact who can create a specification to match your requirements using the Volvo Sales Support system (VSS).

The factory reserves the right to modify design and change equipment without previous notification. The specification can vary from country to country.

MODEL RANGE

NEW FMX11 6x4 Tractor - Rear Air Suspension - N3 or N3G FMX 64T 1A

VOLVO

Volvo Truck Corporation
volvotrucks.com