

# MODEL RANGE

FMX LNG 64 Rigid Rear Air FMX 64R LA2

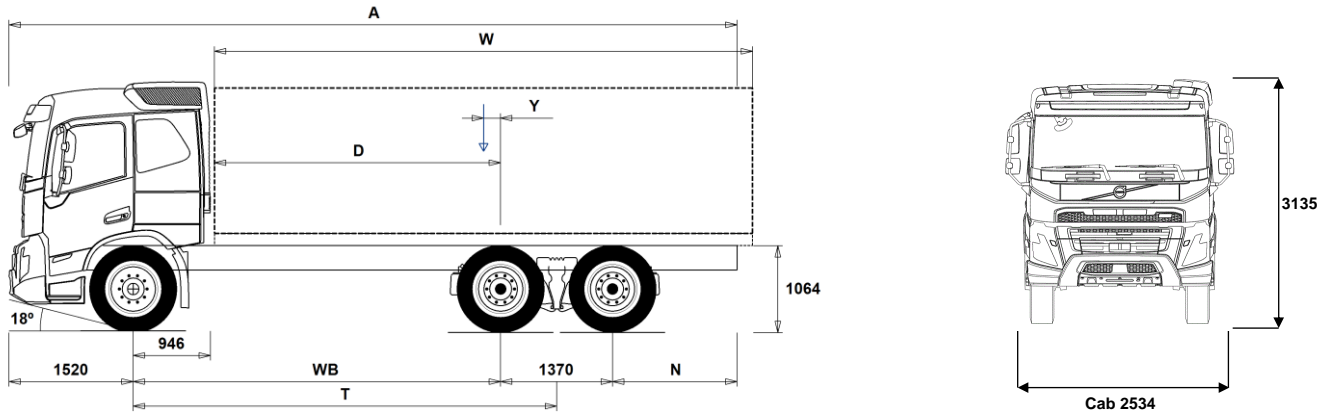

## Chassis Dimensions [mm]

WB Wheelbase	4300	4600	4900	5200
A Overall Chassis Length	9565	10715	10465	10965
D Center of rear axle to front of body	3304	3604	3904	4204
N Rear Overhang (Min.)	825	825	825	1225
N Rear Overhang (Max.)	2375	3225	2675	2875
T Theoretical Wheelbase	4985	5285	5585	5885
Y Center of Gravity for Payload (Min.)	21	69	93	131
Y Center of Gravity for Payload (Max.)	21	69	93	131
W Body Length (Min.)	6566	7069	7620	8144
W Body Length (Max.)	6566	7069	7620	8144

## Chassis Weights [kg]

Front Axle	5145	5135	5200	5215
Rear Bogie	3685	3800	3715	3735
Kerb Weight	8830	8935	8915	8950
Payload (including body, driver, fuel, etc.)	20170	20065	20085	20050

## Turning Diameter [mm]

Turning Circle Diameter Kerb to Kerb	18100	19000	20000	21000
Turning Circle Diameter Wall to Wall	19500	20500	21400	22400

## Plated Weights [kg]

	Design
Gross Vehicle Weight	29000
Gross Combination Weight	44000
Front Axle	8000
Rear Bogie	21000

## Important Notes

### Chassis Dimensions

Cab Height: +312 mm for CAB-HSLP.  
 D-measure includes a front clearance of 50 mm and for rigid trucks also a subframe of 100 mm.  
 Height can vary ± 20 mm for leaf and ± 10 mm for air suspension.  
 All dimensions are for unladen chassis and any tag axles down. Chassis height used: CHH-HIGH.  
 Rear overhang used for vehicle weight calculation is the maximum rear overhang (N Max.) for selected wheelbase.  
 Height change when chassis height CHH-MED,FRAME300: 0 mm.

Weight and dimensions are based upon the following tyres:  
 Front Axle Tyres: 315/80R22.5  
 Drive Axle Tyres: 315/80R22.5

**Chassis weight includes oil, water, AdBlue, 0 litres fuel and without driver. Kerb weight can vary ± 3%.**

Turning diameters are theoretically calculated.

Legal weights can differ from country to country.

For more detailed weight information, including optional equipment weights, ask your Volvo sales contact to enter your specification into the Volvo Weight Information system (WIS).

Do NOT use this drawing for bodybuilding. Refer to Volvo Bodybuilder Instructions and chassis assembly drawing FMX64RLA2.

# MODEL RANGE

## FMX LNG 64 Rigid Rear Air FMX 64R LA2

### Core components

- CHH-HIGH** Chassis height high - approx. 1000 mm above ground level
- CHH-MED** Chassis height medium - approx. 900 mm above ground level
- **RADD-GR** Rear air suspension, 2 axles - 2 driven
- FMX-HSL5** FMX Globetrotter sleeper cab
- FMX-LSL5** FMX Low sleeper cab
- **FMX-SLP5** FMX Sleeper cab
- **G13C420** Gas engine, 13 litre, 420 hp
- G13C460** Gas engine, 13 litre, 460 hp
- EBR-EPGC** Exhaust pressure governor with Volvo compression brake
- EBR-VEB+** Volvo Engine Brake, VEB+ (high efficiency compression brake with exhaust pressure governor, EPG)
- AT2412** I-Shift automated mechanical 12-speed gearbox without clutch pedal, max. engine torque 2400 Nm, max permitted GCW 44000 kg.
- **AT2412F** I-Shift automated mechanical 12-speed gearbox without clutch pedal, max. engine torque 2400 Nm, max. permitted GCW 44000 kg.
- AT2612F** I-Shift automated mechanical 12-speed gearbox without clutch pedal, max. engine torque 2600 Nm, max. permitted GCW 100000 kg.
- ATO2612F** I-Shift automated mechanical 12-speed overdrive gearbox without clutch, max. engine torque 2600 Nm, max. permitted GCW 100000 kg. Suitable for hub reduction rear axles.
- TAAXLIFT** Tandem axle lift for driven bogie axle
- RTH2610B** Rear hub reduction tandem axles - bogie load 26 tonnes, GCW 100 tonnes, 4 planet gears
- RTH2610F** Rear hub reduction tandem axles - bogie load 26 tonnes, GCW 100 tonnes, version F
- RTS2310A** Rear single reduction tandem axle - bogie load 23 tonnes, GCW 100 tonnes
- **RTS2370A** Rear single reduction tandem axles - bogie load 23 tonnes, GCW 70 tonnes

### Packages

- DRIVE5** Driving package
- DRIVE5+** Driving plus package
- DRIVE5++** Driving plus/plus package
- 1LIVINFM** Living package 1 person
- 2LIVINFM** Living package 2 persons
- **INFOBAS** Information package, basic
- INFODF** Information package prepared for Dynafleet vehicle onboard support
- INFOMED** Information package, medium
- INFONAV** Information package with Navigation support
- INFONDF** Information package with Navigation support and prepared for Dynafleet vehicle onboard support
- VISIX5** Visibility package FMX
- VISIXCAM**
- GSR2024** General safety regulations 2024
- GSR2024+** General safety regulations 2024 plus
- SAFE22** Safety package (VTE)
- SAFE22+** Safety Plus package (VTE)

### Chassis

- FST-AIR** Front air suspension
- **FST-PAR** 2 leaf front parabolic suspension (normal stiffness)
- FSL5-BAS** Front air suspension basic levelling stroke
- FSL5-HI** Front air suspension high levelling stroke
- FAL10.0** Front axle load 10.0 tonnes
- FAL7.1** Front axle load 7.1 tonnes
- FAL7.5** Front axle load 7.5 tonnes
- **FAL8.0** Front axle load 8.0 tonnes
- FAL8.5** Front axle load 8.5 tonnes
- FAL9.0** Front axle load 9.0 tonnes
- **FSTAB** Front stabilizer with normal stiffness

- FSTAB2** Front stabilizer with medium high stiffness
- FSTAB3** Front stiff stabilizer
- **RAL21** Rear axles load 21 tonnes
- RAL23** Rear axles load 23 tonnes
- RAL26** Rear axles load 26 tonnes
- **RSTAB1** Rear stabilizer with normal stiffness
- RSTAB3** Rear stiff stabilizer
- **RALIM105** First rear drive axle load limiter, 10.5 tonnes (speed controlled)
- RALIM115** First rear drive axle load limiter, 11.5 tonnes (speed controlled)
- RALIM13** First rear drive axle load limiter, 13 tonnes
- RALIM95** First rear drive axle load limiter, 9.5 tonnes
- **ASF-DL1** Air suspension with 1 driving level
- ACTST-TO** Volvo Dynamic Steering (VDS) with extra pump and torque overlay
- ASFE-BAS** Volvo Dynamic Steering feature basic
- ASFE-OG** Volvo Dynamic Steering stability assist
- ASFE-PO** Volvo Dynamic Steering personal settings, stability assist
- ASFE-PS** Volvo Dynamic Steering personal settings
- **PSS-SING** Single power steering system
- **PSP-VAR** Power steering pump with variable displacement
- **EBS-MED** EBS (Electronic Brake System) medium package:
  - ABS (Anti-lock Braking System)
  - Lining Wear Sensing (20 % left)
  - Lining Wear Control (incl. wear on the axle)
  - Brake Blending
  - Drag Torque Control
  - Diff Lock Synchronization
  - Diff lock Control
  - Brake Temperature Warning
  - External Brake Demand
  - Diagnosis Via Truck Electronic System
  - Traction Control System
  - Emergency Brake Assistance
  - Constant Wheel Brake Monitoring
  - Coupling Force Control
  - Automatic Parking Brake Activation
  - Lining Wear Analyses (calc of remaining mileage)
  - Auto hold
  - EBS status monitoring via Truck Electronic System
- AUXPARK** Two extra parking brake chambers
- **RST-AIR** Rear air suspension
- **SUSPL-EC** Air suspension levelling with electronic control
- FRAME266** Frame rail section external height 266 mm
- **FRAME300** Frame rail section external height 300 mm
- FST7070** Frame section thickness - web 7.0 mm / flange 7.0 mm
- **FST8080** Frame section thickness - web 8.0 mm / flange 8.0 mm
- FIL-EEEB** Frame inner liner from end of engine end to end of bogie
- FIL-EEEF** Frame inner liner from end of engine end to end of frame
- FIL-FBEB** Frame inner liner from front of bogie to end of bogie
- FIL-FBEF** Frame inner liner from front of bogie to end of frame
- FIL-TXEB** Frame inner liner from transmission cross member to end of bogie
- FIL-TXEF** Frame inner liner from transmission cross member to end of frame
- **BBOX-L** Battery box on left hand side
- **BATS-S** Single energy battery storage system (2 batteries)
- **2BAT210C** AGM batteries 2x210 Ah
- 2BATT170** Batteries 2x170 Ah
- 2BATT225** Batteries 2x225 Ah
- **BATTAMP** Battery voltage and ampere gauge
- BATTIND** Battery voltage, ampere and battery status gauge with visual alerts

■ Standard Equipment      □ Optional Equipment

For more detailed information about cab and powertrain equipment, please refer to separate specification sheets.

For all possible options and combinations of options please consult your Volvo sales contact who can create a specification to match your requirements using the Volvo Sales Support system (VSS).

The factory reserves the right to modify design and change equipment without previous notification. The specification can vary from country to country.

# MODEL RANGE

## FMX LNG 64 Rigid Rear Air FMX 64R LA2

<ul style="list-style-type: none"> <li>□ <b>ADR2</b> ADR adaptation - transportation of dangerous goods, 2 switches (1 inside cab in dashboard, 1 outside on cab back passenger side).</li> <li>□ <b>MSWI-A</b> ADR main switch - ADR switch circuit shut down</li> <li>■ <b>MSWI-C</b> Chassis main switch - battery box placed toggle switch circuit shut down</li> <li>□ <b>MSWI-R</b> Remote controlled main switch - key fob operated circuit shut down</li> <li>■ <b>R170A71</b> Right 170 litre aluminium 710 mm high D-shaped diesel tank Min volume 170l Max volume 170l</li> <li>■ <b>ADTP-R</b> AdBlue tank on right hand side</li> <li>■ <b>ADB064</b> AdBlue tank usable volume 64 litres, 710 mm high mounted on chassi side.</li> <li>■ <b>FCAP-L</b> The variant includes two or three lockable caps, one or two for the fuel tank(s) and one for the AdBlue tank, and two keys that fit all tank locks (not cab door locks). The number of fuel tank caps are depending of how many fuel tanks that are specified.</li> <li>■ <b>FUFF-AS</b> Fuel filling anti-spillage device</li> <li>□ <b>FUFF-ATS</b> Fuel filling anti-theft and anti-spillage devices</li> <li>□ <b>LGAS155</b> Left 155 kilogram gas tank</li> <li>□ <b>LGAS205</b> Left 205 kilogram gas tank</li> <li>□ <b>ESH-LEFT</b> Horizontal muffler, left exhaust outlet</li> <li>■ <b>ESH-REAR</b> Horizontal muffler, rear exhaust outlet</li> <li>□ <b>HS-NAR</b> Narrow Euro 6 muffler heat shield. Partly (due to heat release) reduced distance (moved inwards) to silencer. Makes better space for e.g. support legs.</li> <li>□ <b>WHC-FIX2</b> Two fixed wheel chocks</li> <li>■ <b>WHC-FOL2</b> 2 foldable wheel chocks</li> <li>□ <b>WHCP-F</b> Wheel chock(s) in the front part of the vehicle. - TRACTOR, BBOX-L, Fold, 1/2 w chocks = Top of left side battery box - TRACTOR, BBOX-EF, Fold, 1/2 w chocks = Top of lefts side fuel tank - TRACTOR, BBOX-EF, Fix, 2 w chocks = Left frame front of fuel tank - RIGID, 1 front axle, Fold, 1/2 w chocks = Top of left side battery box - RIGID, 2 front axles, Fold, Frame free space, 2 wc = Top of left side battery box - RIGID, 2 front axles, Fix, W/o frame free space, 2 wc = Left frame behind 1st front wheel</li> <li>□ <b>WHCP-R</b> Wheel chock(s) in the rear part of the vehicle - RIGID, 1 front axle, Fix, 1/2 w chocks = Left frame rear (or front) of rear wheels</li> <li>□ <b>WHCP-T</b> Transport mounted wheel chock(s) in cab outer luggage compartment</li> <li>□ <b>TB-R80</b> Right toolbox 800 mm length (mounting length 800 mm, real length 730 mm)</li> <li>□ <b>CHAIN-S</b> The non-skid chains are on economical safety accessory that provides good grip owing to its square profile and S-shaped pattern. They are made of micro-alloy manganese steel and have a weight of 21 kg each. Using the chains does not cause any imbalance. They are supplied individually in sacks and spares are supplied with each chain. The variant includes one pair of chains except for all wheel drive 6*6, where two pairs are enclosed</li> <li>□ <b>HOOK-SC</b> The galvanised steel hooks are a practical solution developed to store the snow chains. For Rigid's there are two hooks attached in pre-punched holes on each side of the frame rail side of the rear frame overhang. On Tractors, two hooks are mounted in an existing hole pattern on the end of the rear frame overhang and a protection shield prevents the air tank from being damaged by</li> </ul>	<ul style="list-style-type: none"> <li>the snow chains. The hooks will protrude approximately 200 mm behind the chassis frame end. The weight increase for the four hooks on Rigid's is approximately 3.5 kg and for Tractors with protection shield it is approximately 3 kg</li> <li>■ <b>TOWF-HD1</b> One heavy duty front towing device</li> <li>□ <b>TOWMBRH</b> High mounted towing member, in centre of frame</li> <li>□ <b>TOWMBRL1</b> Towing member, low mounted under the frame (position 1)</li> <li>□ <b>TOWMBRL2</b> Towing member, low and forward mounted under the frame (position 2)</li> <li>□ <b>TOWMBRL3</b> Towing member, low and far forward mounted under the frame, (position 3)</li> <li>□ <b>TOWMBRM</b> Towing member, medium mounted in line with frame lower flange</li> <li>□ <b>RFEC-L</b> Rear frame end, lower cut (for centre axle drawbar)</li> <li>■ <b>RFEC-S</b> Rear frame end, straight cut (for regular platform applications)</li> <li>□ <b>RFEC-U</b> Rear frame end, upper cut (for e.g. tipper, refuse and hooklift applications)</li> <li>□ <b>C-RI4040</b> Towing coupling Ringfeder RF4040A G-150</li> <li>□ <b>C-RI4045</b> Towing coupling Ringfeder RF4045A G-150</li> <li>□ <b>C-RI5050</b> Towing coupling Ringfeder RF5050A G-150</li> <li>□ <b>C-RO400G</b> Towing coupling Rockinger 400 G-150</li> <li>□ <b>C-RO50</b> Towing coupling Rockinger 50 mm</li> <li>□ <b>C-VBG520</b> Towing coupling VBG 5200D</li> <li>□ <b>C-VBG795</b> Towing coupling VBG 795V</li> <li>□ <b>TOWR-ONE</b> One rear towing device in frame end cross member</li> <li>■ <b>TREL-PK</b> Trailer electrical preparation kit (chassis/cab wiring)</li> <li>□ <b>TREL15</b> 15 pol electrical trailer connector (ADR certified)</li> <li>□ <b>TREL7-7</b> 2x7 pol (24N+24S) electrical trailer connectors (UADR)</li> <li>□ <b>TBC-DUO</b> Trailer brake connection, Duomatic</li> <li>□ <b>TBC-EC</b> Trailer brake connection, European Community</li> <li>□ <b>TRBR-STA</b> Stationary trailer brake control</li> <li>□ <b>TRB-STRE</b> Automatic low speed trailer brake activation (stretch brake) to avoid jack-knifing and to improve steerability</li> <li>□ <b>RUP-FOLD</b> Foldable aluminium rear underrun protection, EC approved</li> <li>□ <b>RFEND-B</b> The fenders have a robust three-piece design with a top part that can easily be removed (no tools required) facilitating access for body building and service. The fenders are manufactured from black plastic and received in different performance to suit chassis height and tyre dimension. The fender design fulfils the technical requirements of current EU directive.</li> <li>□ <b>RFEND-T</b> The rear fenders are temporary fixed on the frame of Rigid trucks for transport on own wheels from factory to body builder. This is done in order to fulfill legal safety requirements. There are two different sizes of fenders, one for single tyres and one for twin tyres.</li> <li>□ <b>RFH-BAS</b> Optimal fender installation (rear and 2nd front axle) with regard to legal demands, wheel/tyre sizes, chassis height and fifth wheel height.</li> <li>□ <b>RFH-HIG</b> Highest fender installation (rear and 2nd front axle). Suitable for rough and very rough road conditions.</li> <li>□ <b>RFH-LOW</b> Lower fender installation (rear and 2nd front axle). Suitable only for smooth road conditions. Increased risk of fender top wear.</li> <li>□ <b>AUXATNK</b> With an auxiliary air tank the truck will have extra capacity for the air suspension system. This is especially useful when the driver frequently uses the levelling system with the engine turned off (i.e. when the compressor is not operating). The levelling system's reaction time also improves with this extra tank. The position of the tank varies depending on the position of the spare wheel carrier: - Above the spare wheel when the spare wheel carrier is fitted ahead of the</li> </ul>
---	---

■ Standard Equipment      □ Optional Equipment

For more detailed information about cab and powertrain equipment, please refer to separate specification sheets.

For all possible options and combinations of options please consult your Volvo sales contact who can create a specification to match your requirements using the Volvo Sales Support system (VSS).

The factory reserves the right to modify design and change equipment without previous notification. The specification can vary from country to country.

# MODEL RANGE

## FMX LNG 64 Rigid Rear Air FMX 64R LA2

<ul style="list-style-type: none"> <li>□ <b>ATANK-AL</b> Aluminium air tanks</li> <li>■ <b>ATANK-ST</b> Steel air tanks</li> <li>□ <b>REST-RUP</b> Reflecting red stripes mounted on rear underrun protection</li> <li>□ <b>TL-LED</b> The LED tail lamp has all functions integrated in the lamp housing: Tail light, exterior marker light, brake light, hazard warning, reverse light, rear fog light and reflector. All light functions have LED (Light Emitting Diode) lights, which means very low energy consumption. LED lamps are insensitive to vibration and have a very long operating life. They shine with the same high intensity throughout their lifetime.</li> <li>■ <b>BLIGHT-E</b> Flashing brake lights will automatically activate in emergency braking. The flashing frequency is 4 Hz and emergency braking is detected if speed exceeds 50km/h and retardation is 4 m/s<sup>2</sup> or more. The function deactivates when retardation is less than 2.5 m/s<sup>2</sup> <ul style="list-style-type: none"> <li>- Easier for road users to detect emergency braking.</li> <li>- Contributes to safety in congested traffic</li> </ul> </li> <li>□ <b>FRACLOS</b> Frame end closing</li> </ul>	<p>axle on the left side (SWCP-LF).                      – Under the frame on the left side for all other positions of the spare wheel carrier.                      The auxiliary air tank is available for 6x2/6x4/8x4 with rear air suspension</p>	<ul style="list-style-type: none"> <li>■ <b>JACK-20T</b> height of 435 mm. Weight: 10.8 kg                      The hydraulic jack has a capacity of 20 tonnes and its low manual pumping force facilitates use in uncomfortable positions. It has a release valve, which permits safe, easy and precise control over rate of lowering and a filter in the oil reservoir gives protection from contamination. The jack has a minimum height of 190 mm and a maximum height of 325 mm. Weight: 11.5 kg</li> <li>■ <b>TOOL-BAS</b> This kit consists of a tool bag (case) including the following tools:                     <ul style="list-style-type: none"> <li>• Combination screwdriver.</li> <li>– 1 screwdriver handle</li> <li>– 1 blade, Philips/flat blade</li> <li>– 1 blade, Torx T10/Torx T20</li> <li>– 1 blade, Torx T25/Torx T27</li> <li>– 1 blade, Torx T30/Torx T40</li> <li>• Socket wrench.</li> </ul> </li> <li>□ <b>TOOLKIT</b> This kit consists of a tool bag (case) including the following tools:                     <ul style="list-style-type: none"> <li>• Combination screwdriver.</li> <li>– 1 screwdriver handle</li> <li>– 1 blade, Philips/flat blade</li> <li>– 1 blade, Torx T10/Torx T20</li> <li>– 1 blade, Torx T25/Torx T27</li> <li>– 1 blade, Torx T30/Torx T40</li> <li>• Socket wrench.</li> <li>• Adjustable pliers.</li> <li>• Allen key.</li> <li>• Adjustable spanner.</li> <li>• Hammer.</li> </ul> </li> <li>■ <b>INFLAHOS</b> The tyre inflation hose is a 18 meter long air hose made of high quality rubber and equipped with nozzles on both ends. It can be used for filling air into a tyre by connecting the hose to an air tank valve on the truck. The tyre inflation hose is stored in the cab compartment for clean and easy access, either in the external luggage compartment (sleeper cab) or behind the seat (day cab).</li> <li>□ <b>GAUGE-TP</b> Tyre pressure gauge</li> </ul>
<h3>Rims and Tyres</h3>		
<ul style="list-style-type: none"> <li>□ <b>RT-AL</b> Brushed aluminium rims with std holes (long stud fixing) on all axles</li> <li>□ <b>RT-ALDP</b> Dura-Bright polished aluminium rims with std holes (long stud fixing) on all axles</li> <li>□ <b>RT-ALDPD</b> Dura-Bright polished aluminium rims with countersunk holes (short stud fixing) on all axles</li> <li>□ <b>RT-ALDU</b> Brushed aluminium rims with countersunk holes (short stud fixing) on all axles</li> <li>■ <b>RT-STEEL</b> Steel rims on all axles</li> <li>□ <b>WCAP</b> Wheel caps</li> <li>□ <b>SPWT-D</b> Spare wheel with tyre equal to drive</li> <li>□ <b>SPWT-F</b> Spare wheel with tyre equal to front wheel</li> <li>□ <b>SWCP-R</b> Rear mounted spare wheel carrier behind axle on the right hand side of the chassis. It is preferred for longer wheelbases, WB4300 and longer. Due to the spare wheel carrier's location on the rear overhang, all chassis space between front and rear axles can be used for fuel tanks, toolboxes etc.</li> <li>□ <b>SWCP-T</b> Plastic strips strapped to the chassis are used as a temporary spare wheel carrier. Note that the mounting only is temporary and used during transportation.</li> <li>□ <b>SWCP-TP</b> Plastic strips strapped to the chassis are used as a temporary spare wheel carrier. Note that the mounting only is temporary and used during transportation. An ordinary spare wheel carrier is also included. This carrier is transport mounted on top of the temporarily chassis frame strapped spare wheel.</li> <li>□ <b>JACK-12T</b> The hydraulic jack has a capacity of 12 tonnes and its low manual pumping force facilitates use in uncomfortable positions. It has a release valve, which permits safe, easy and precise control over rate of lowering and a filter in the oil reservoir gives protection from contamination. The jack has a minimum height of 180 mm and a maximum height of 315 mm. Weight: 7.3 kg</li> <li>□ <b>JACK-15T</b> The hydraulic jack has a capacity of 15 tonnes and its low manual pumping force facilitates use in uncomfortable positions. It has a release valve, which permits safe, easy and precise control over rate of lowering and a filter in the oil reservoir gives protection from contamination. The jack has a minimum height of 225 mm and a maximum</li> </ul>	<ul style="list-style-type: none"> <li>■ <b>Standard Equipment</b></li> <li>□ <b>Optional Equipment</b></li> </ul>	

For more detailed information about cab and powertrain equipment, please refer to separate specification sheets.

For all possible options and combinations of options please consult your Volvo sales contact who can create a specification to match your requirements using the Volvo Sales Support system (VSS).

The factory reserves the right to modify design and change equipment without previous notification. The specification can vary from country to country.

# MODEL RANGE

## FMX LNG 64 Rigid Rear Air FMX 64R LA2

<input type="checkbox"/> <b>2COM1100</b>	Dual cylinder air compressor 760 cc / 1100 l/min	<input type="checkbox"/> <b>DRC-AMII</b>	Regeneration control of diesel filter particulates - auto initiation / manual on demand / manual inhibition
<input checked="" type="checkbox"/> <b>2COMP900</b>	Dual cylinder air compressor - 636 cc	<input checked="" type="checkbox"/> <b>DRC-AUTO</b>	Regeneration control of diesel filter particulates - fully automatic (in motion)
<input type="checkbox"/> <b>CLU-AIRC</b>	Air compressor clutch automatically declutched when not needed in order to save fuel	<input type="checkbox"/> <b>1DAYDIG2</b>	Gen 2 one day digital tachograph, EC approved
<input checked="" type="checkbox"/> <b>AIRIN-HI</b>	High air intake	<input checked="" type="checkbox"/> <b>1DAYDIG4</b>	Gen 4 one day digital tachograph, EC approved
<input type="checkbox"/> <b>AIRIN-LO</b>	Low air intake	<input type="checkbox"/> <b>ARSL</b>	Additional road speed limiter (switch in dashboard) The additional road speed limiter allows the driver to define a temporary speed limit for the truck. This is a useful feature when entering a low-speed area. The driver activates the additional speed limiter by pressing a switch on the instrument panel and the current speed becomes the limit. The speed limiter is deactivated by pressing the switch and releasing the accelerator, lifting off to below 20% engagement.
<input type="checkbox"/> <b>ACL1ST-S</b>	Air cleaner with additional filter element (primary + secondary)	<input type="checkbox"/> <b>SPEED-DU</b>	SPEED-DU is an electrical preparation kit for rear loaded refuse collection vehicles. The SPEED-DU variant supports the fulfillment of the demands in regulation EN1501-1 for "foot step" at the back of the truck. Trucks ordered with this variant are equipped with a BBM electronic control unit connector with prepared wires often used by RCVs. The Speed limit function limits the vehicle speed to default 30 km/h when there is an input from the chassis on the "foot step" input. It will also apply the brakes and force the engine to low idle if the gear lever is put into reverse gear position while the "foot step" input is active. It will, at the same time, inhibit the reverse gear from being engaged in trucks equipped with the Powertronic or I-Shift-gearbox, provided that the I-Shift is equipped with the gearbox variant APF-ENH. A special icon is shown in the instrument cluster display when the function is active (footstep occupied).
<input checked="" type="checkbox"/> <b>24AL110B</b>	Alternator 110 Ampere	<input checked="" type="checkbox"/> <b>ESP-BAS1</b>	Electronic Stability Program package intended for RIGID single vehicles or vehicle combinations with standard centre of gravity height when laden and for TRACTOR vehicle combinations with a single trailer or multiple trailers with ABS/EBS.
<input type="checkbox"/> <b>24AL150B</b>	Alternator 150 Ampere	<input type="checkbox"/> <b>ESPC-RO</b>	ESP (Electronic Stability Program) functionality control - Reduced / Off
<input checked="" type="checkbox"/> <b>EST-AID</b>	Engine start pre-heating element	<input type="checkbox"/> <b>HWSS-AC</b>	Adaptive cruise control with forward collision warning
<input type="checkbox"/> <b>220EBH15</b>	Engine block heater, 220 volt, 1.5 kW	<input type="checkbox"/> <b>HWSS-ACB</b>	Adaptive cruise control with forward collision warning (stationary and moving objects) and emergency braking. Using both radar and camera to collect info.
<input type="checkbox"/> <b>PTER-DIN</b>	Rear engine mounted clutch independent PTO with splined shaft groove (female) for a close coupled pump (DIN 5462 / ISO 7653)	<input checked="" type="checkbox"/> <b>HWSS-FCB</b>	Forward collision warning (stationary and moving objects) with emergency braking
<input type="checkbox"/> <b>PTR-D</b>	Mechanical gearbox driven low speed power take-off, 1 rear connection (DIN 5462 / ISO 7653) for plug-in pump (max. 1000 Nm).	<input type="checkbox"/> <b>LSS-DW</b>	Lane keeping support - lane departure warning system
<input type="checkbox"/> <b>PTR-DH</b>	Mechanical gearbox driven high speed power take-off, 1 rear connection (DIN 5462 / ISO 7653) for plug-in pump (max. 600 Nm).	<input type="checkbox"/> <b>LCS</b>	Lane Change Support
<input type="checkbox"/> <b>PTR-DM</b>	Mechanical gearbox driven medium speed power take-off, 1 rear connection (DIN 5462 / ISO 7653) for plug-in pump (max. 600 Nm).	<input type="checkbox"/> <b>LCS4</b>	Side Collision Avoidance Support, passenger and driver side
<input type="checkbox"/> <b>PTR-F</b>	Mechanical gearbox driven low speed power take-off, 1 rear flange connection (SAE 1410 / ISO 7647) for propeller shaft (max. 1000 Nm).	<input type="checkbox"/> <b>DAS-W</b>	Driver Alert Support (drowsy driver warning)
<input type="checkbox"/> <b>PTR-FH</b>	Mechanical gearbox driven high speed power take-off, 1 rear flange connection (SAE 1310 / ISO 7647) for propeller shaft (max. 600 Nm).	<input type="checkbox"/> <b>RSENS-W</b>	Wiper rain sensor
<input type="checkbox"/> <b>PTR-FL</b>	Mechanical gearbox driven low speed power take-off, 1 rear flange connection (SAE 1310 / ISO 7647) for propeller shaft (max. 600 Nm).	<input type="checkbox"/> <b>CU-ECC</b>	Fully electrically controlled air conditioning with sun sensor
<input type="checkbox"/> <b>PTRD-D</b>	Mechanical gearbox driven high speed power take-off, 1 rear and 1 front connections (DIN 5462 / ISO 7653) for plug-in pumps (max. 870 Nm).	<input type="checkbox"/> <b>CU-ECC2</b>	Fully electrically controlled air conditioning with sun sensor, mist sensor, air quality sensor and carbon filter
<input type="checkbox"/> <b>PTRD-D1</b>	Mechanical gearbox driven high speed power take-off, 1 rear flange connection (SAE 1410 / ISO 7647) for propeller shaft / 1 front connection (DIN 5462 / ISO 7653) for plug-in pump (max. 870 Nm).	<input checked="" type="checkbox"/> <b>CU-MCC</b>	Electrical manually controlled air conditioning
<input type="checkbox"/> <b>PTRD-D2</b>	Mechanical gearbox driven power take-off, 2 rear flange (high-speed) connections (SAE 1310/1410 / ISO 7647) for propeller shafts / 1 front (high speed) connection (DIN 5462 / ISO 7653) for plug-in pump (max. 870/1000 Nm).	<input checked="" type="checkbox"/> <b>IMMOBIL</b>	Immobiliser
<input type="checkbox"/> <b>PTRD-F</b>	Mechanical gearbox driven high speed power take-off, 1 rear flange connection (SAE 1410 / ISO 7647) for propeller shaft (max. 870 Nm).	<input type="checkbox"/> <b>ALARM-B</b>	Burglar alarm - cab
<input type="checkbox"/> <b>HPG-F101</b>	Gearbox mounted hydraulic pump F1-101, fixed displacement, single flow	<input type="checkbox"/> <b>ALARM-E</b>	Burglar alarm - cab/body/trailer
<input type="checkbox"/> <b>HPG-F41</b>	Gearbox mounted hydraulic pump F1-41, fixed displacement, single flow		
<input type="checkbox"/> <b>HPG-F51</b>	Gearbox mounted hydraulic pump F1-51, fixed displacement, single flow		
<input type="checkbox"/> <b>HPG-F61</b>	Gearbox mounted hydraulic pump F1-61, fixed displacement, single flow		
<input type="checkbox"/> <b>HPG-F81</b>	Gearbox mounted hydraulic pump F1-81, fixed displacement, single flow		

### Cab Interior, Driving

<input checked="" type="checkbox"/> <b>STWPOS-L</b>	Left hand drive
<input type="checkbox"/> <b>STWM-LE</b>	Leather steering wheel
<input type="checkbox"/> <b>STGW-AD2</b>	Mechanically adjustable steering wheel with neck tilt
<input checked="" type="checkbox"/> <b>STGW-ADJ</b>	Mechanically adjustable steering wheel
<input type="checkbox"/> <b>AIRBAG</b>	Airbag on driver side
<input type="checkbox"/> <b>INST-BAS</b>	24-HDV - Instrumentation, high performance 12" fully dynamic instrument cluster. CLASS-HDV - Basic level instrument cluster - 4 inch monochrome display 240x320 pix

Standard Equipment

Optional Equipment

For more detailed information about cab and powertrain equipment, please refer to separate specification sheets.

For all possible options and combinations of options please consult your Volvo sales contact who can create a specification to match your requirements using the Volvo Sales Support system (VSS).

The factory reserves the right to modify design and change equipment without previous notification. The specification can vary from country to country.

# MODEL RANGE

## FMX LNG 64 Rigid Rear Air FMX 64R LA2

<ul style="list-style-type: none"> <li>□ <b>PHONE-PK</b> Telephone preparation kit (antenna, antenna attachment, cable from antenna to radio shelf).</li> <li>□ <b>ISUNS-BS</b> Manually manoeuvred side interior sun visor (roller blind type) on both sides</li> <li>■ <b>ISUNS-DS</b> Manually manoeuvred side interior sun visor (roller blind type) on driver side</li> <li>□ <b>ISUNF-B</b> Interior front plastic sun visors (driver and passenger side) without mirror on driver side</li> <li>□ <b>ISUNF-MD</b> Interior front plastic sun visors (driver and passenger side) with mirror on driver side</li> <li>□ <b>ISUNF-RE</b> Electrical textile interior sun visor (roller blind) integrated in front shelf</li> <li>■ <b>ISUNF-RM</b> Manual interior textile sun visor (roller-blind) integrated in front shelf</li> <li>□ <b>ADFS</b> Two extra DIN slots in front shelf (push/pull storage), 165x40x180 mm (WxHxD)</li> <li>□ <b>BUPALARM</b> Reversing warning unit (back-up alarm)</li> <li>□ <b>RTOLL-PK</b> Preparation kit for road toll collect (GPS/GSM antenna and cables)</li> <li>□ <b>LOADIND</b> Load indicator with dashboard display. Measures axle pressures, load weight and total weight of truck and one trailer.</li> <li>□ <b>REMC-MF</b> Wireless remote control - multi functional</li> <li>□ <b>FIREXT2G</b> The fire extinguisher is an important part of the safety equipment. It is extremely reliable, has a high capacity and withstands temperatures down to -30°C. The fire extinguisher manages to extinguish fires in electrical systems and brakes. It is located on the driver side*, beside the seat, which makes it easy to reach in case of an accident. The placement of the fire extinguisher may vary depending on the specification, but it is always easily reachable by the driver.</li> <li>□ <b>FIREXT3S</b> The fire extinguisher is an important part of the safety equipment. It is extremely reliable, has a high capacity and withstands temperatures down to -30°C. The fire extinguisher manages to extinguish fires in electrical systems and brakes. It is located on the driver side*, beside the seat, which makes it easy to reach in case of an accident. The placement of the fire extinguisher may vary depending on the specification, but it is always easily reachable by the driver.</li> <li>□ <b>WARNVEST</b> The reflective vest makes a person clearly visible during work near a vehicle when it is dark or during other occasions when it is difficult to observe a person. It is made of yellow fluorescent textile, 100 % polyester, and it features two 50 mm wide reflective strips at the front and back. The reflective material is resistant to fuel and oil and works well in both wet and dry weather. The vest is stored in a plastic bag and it is washable at 40°C. Fulfills European standard according to EN 471 class 2.</li> <li>■ <b>WARNTRI2</b> Warning triangles are an important safety detail. They offer extra security in the event of an unplanned stop at the roadside, when they alert other road users to be careful and slow down in the area. Two triangles give the opportunity to observe vehicles in both direction, one to be positioned ahead of the truck and the second one behind. The two triangles are delivered in the tool box behind left seat, stripes for tool bag or on the left shelf luggage compartment</li> <li>■ <b>AIDKIT</b> The first-aid kit features a well thought-out assortment of emergency treatment products for both minor and severe injuries: <ul style="list-style-type: none"> <li>• 1 first-aid instruction</li> <li>• 1 pair of scissors</li> <li>• 2 triangular bandage, unbleached cotton cloth</li> <li>• 2 pairs of protective gloves (large)</li> </ul> </li> </ul>	<ul style="list-style-type: none"> <li>• 3 gauze bandages 80x4000 mm</li> <li>• 2 gauze bandages 60x4000 mm</li> <li>• 1 bandaging cloth 600x800 mm</li> <li>• 2 bandaging cloths 400x600 mm</li> <li>• 6 gauze dressings 100x100 mm (3x2)</li> <li>• 1 adhesive bandage 60x100 mm</li> <li>• 1 adhesive tape 25x5000 mm</li> <li>• 1 first-aid packet 100x120 mm</li> <li>• 3 first-aid packets 80x100 mm</li> <li>• 1 rescue sheet 1600x2100 mm (gold/silver)</li> </ul> <p>□ <b>AIDKIT1B</b> First aid kit containing sticking plaster, compresses, elastic bandages, gloves, scissors, triangular bandage, bandaging cloths, adhesive tape and rescue sheet (German requirements)</p> <p>□ <b>WARNLAMP</b> Portable warning lamp with batteries</p> <p>□ <b>LAMP-IN</b> The inspection lamp is a device that is used to illuminate repairing areas during night or when the day light is not enough. It has a plug for connection into the lighter socket. The length of the electrical cable is 10 meters. The lamp is stored in a storage compartment on driver</p> <p>□ <b>BULBKIT</b> Bulb and fuse kit</p> <p>□ <b>WRITEPAD</b> Writing pad with spring-loaded paper clip</p>
<p><b>Cab Interior, Living</b></p> <ul style="list-style-type: none"> <li>■ <b>DST-CF1</b> Driver seat, comfort, suspended</li> <li>□ <b>DST-CF4</b> Driver seat, comfort, suspended, belt in seat</li> <li>□ <b>DST-CF5</b> Driver seat, comfort, suspended, belt in seat, electrically heated</li> <li>□ <b>DST-CF6</b> Driver seat, comfort, suspended, belt in seat, electrically heated, ventilated</li> <li>□ <b>SBD-RED</b> A three-point safety belt is the most effective system to reduce the risk of injuries in a traffic accident. The belts keep the driver and the passenger in position and catch the body in the best possible way in case of a collision. The red coloured safety belt improves and increases the safety image for transport companies, when it thanks to the clear colour is noticed and thereby distributes good reputation.</li> <li>□ <b>SBPRE-DS</b> Driver seat belt pretensioner</li> <li>□ <b>PST-BAS1</b> Passenger seat, basic, non suspended</li> <li>□ <b>PST-CF4</b> Passenger seat, comfort, suspended, belt in seat</li> <li>□ <b>PST-CF5</b> Passenger seat, comfort, suspended, belt in seat, electrically heated</li> <li>■ <b>PST-STD2</b> Passenger seat, regular, non suspended</li> <li>□ <b>PST-STD4</b> Passenger seat, regular, suspended</li> <li>□ <b>SBPRE-PS</b> Passenger seat belt pretensioner</li> <li>□ <b>ARMRE-BB</b> Two armrests on both driver and passenger seats</li> <li>□ <b>ARMRE-DB</b> Two armrests on driver seat</li> <li>□ <b>ARMRE-PB</b> Two armrests on passenger seat</li> <li>□ <b>ARU-BAS</b> Vinyl armrest upholstery</li> <li>□ <b>ARU-LEA</b> Leather armrest upholstery</li> <li>■ <b>FMAT-RUB</b> Two black rubber floor mats</li> <li>□ <b>FMAT-T2E</b> Two dark grey textile floor mats and two black rubber floor mats with an extended side (FMX)</li> <li>□ <b>FMAT-TX2</b> Two textile (dark grey on FH/FM, black on FH16) and two black rubber floor mats</li> <li>■ <b>LBK70</b> Lower fixed bunk, not foldable - 2000x700 mm. Safety net included.</li> <li>□ <b>MATL-FI</b> Mattress lower bunk - firm for over approx. 100 kg, pocket springs.</li> <li>■ <b>MATL-SF</b> Mattress lower bunk - semi-firm up to approx 100 kg, pocket springs.</li> <li>□ <b>OLMAT-BA</b> Overlay mattress protector, 28 mm thick black textile</li> <li>□ <b>OLMAT-PR</b> Overlay mattress protector, 35 mm thick black textile</li> <li>□ <b>TBK60F</b> Fixed top bunk 600x1900 mm, foldable up to 52 degrees to rear wall (depending on cab version and upper storage). Safety net included.</li> </ul>	
<p>■ Standard Equipment      □ Optional Equipment</p>	

For more detailed information about cab and powertrain equipment, please refer to separate specification sheets.

For all possible options and combinations of options please consult your Volvo sales contact who can create a specification to match your requirements using the Volvo Sales Support system (VSS).

The factory reserves the right to modify design and change equipment without previous notification. The specification can vary from country to country.

# MODEL RANGE

## FMX LNG 64 Rigid Rear Air FMX 64R LA2

<ul style="list-style-type: none"> <li><input type="checkbox"/> <b>TBK70F</b> Fixed top bunk 700x1900 mm, foldable up to 52 degrees to rear wall (depending on cab version and upper storage). Safety net included.</li> <li><input type="checkbox"/> <b>PH-CAB2</b> Cab parking heater, 2 kW</li> <li><input type="checkbox"/> <b>PH-ENGCA</b> Engine and cab parking heater</li> <li><input type="checkbox"/> <b>PH-SS</b> Short stop heater</li> <li><input type="checkbox"/> <b>SLCP-BAS</b> Basic sleeper control panel (controlling interior light, parking heater, roof hatch and door lock)</li> <li><input type="checkbox"/> <b>SAFE</b> Key operated safe box under bed (FH) or at bed end (FM)</li> <li><input type="checkbox"/> <b>ETSB-F</b> Storage on engine tunnel - on front top</li> <li><input type="checkbox"/> <b>ETSB-FS</b> Storage on engine tunnel - on front top and storage immersed into tunnel on right hand side</li> <li><input type="checkbox"/> <b>ETSB-S</b> Storage on engine tunnel - immersed into tunnel on right hand side</li> <li><input type="checkbox"/> <b>RUS-BAS</b> Rear cab upper storage 154 litres (300 mm high)</li> <li><input type="checkbox"/> <b>RUS-HIG</b> Rear cab upper storage 245 litres (440 mm high)</li> <li><input type="checkbox"/> <b>TABLE</b> Foldable and height adjustable table to be mounted to the lower bunk</li> <li><input type="checkbox"/> <b>REF-ICPK</b> The kit consists of a bracket that is mounted on the engine tunnel and a hook that is mounted on the refrigerator side in order to strap it down to the bracket. The kit comes with all necessary equipment for installation of both the bracket and the refrigerator.</li> <li><input type="checkbox"/> <b>REFR-RUS</b> 28 litre rear upper wall mounted refrigerator with deviders</li> <li><input type="checkbox"/> <b>MICRO-PK</b> The front shelf above the passenger seat is prepared from factory with prerouted electrical cables for installation of a 24 V microwave oven. Cables for power supply and ground connections are included.</li> <li><input type="checkbox"/> <b>BOTH-D</b> One 1.5 litre plastic soft-drink bottle holder under dashboard centre section</li> <li><input type="checkbox"/> <b>COFMA-PK</b> Preparation kit (24V) for coffee maker</li> <li><input checked="" type="checkbox"/> <b>INLI-BAS</b> Interior white light with smooth light transition at on/off, no dimming</li> <li><input type="checkbox"/> <b>INLI-NL</b> Interior white and red (night) light with smooth light transition at on/off</li> <li><input type="checkbox"/> <b>INLI-NLD</b> Interior white and red (night) light with smooth light transition at on/off and dimmer</li> <li><input type="checkbox"/> <b>ARL-FLEX</b> Two (driver and passenger side) reading lamps with flexible arms (snake lamps) and led lamps fitted on side walls</li> <li><input checked="" type="checkbox"/> <b>RH-EE</b> Without roof hatch, sky window / emergency exit (tinted glass)</li> <li><input type="checkbox"/> <b>RH-ER</b> Roof hatch - Electrically operated / steel / emergency exit handle</li> <li><input type="checkbox"/> <b>RH-ETR</b> Roof hatch - Electrically operated / Tinted glass / Rear opening</li> <li><input type="checkbox"/> <b>RH-MTR</b> Roof hatch - Manually operated / Tinted glass / Rear opening</li> <li><input checked="" type="checkbox"/> <b>GLAS-TIN</b> Tinted windows (front/side/rear)</li> <li><input type="checkbox"/> <b>SWIND-BS</b> Extra side window on both sides</li> <li><input type="checkbox"/> <b>SWIND-PS</b> Rear side window on passenger side</li> <li><input type="checkbox"/> <b>AWIND-RF</b> Rear fixed window (without curtains)</li> <li><input type="checkbox"/> <b>VANMIR</b> Vanity mirror in front shelf lid. In sleeper cab on passenger side and in high/extra high cabs in middle section of the front shelf.</li> <li><input type="checkbox"/> <b>AS-FUS</b> One extra shelf in each of the two front upper storage compartments. Only 1 shelf if microwave oven mounted in one of the two compartments.</li> <li><input type="checkbox"/> <b>INFOT-PK</b> Preparation kit (bracket, security straps, power cable, antenna cable and aux cable) for mounting of a television above driver door.</li> </ul>	<ul style="list-style-type: none"> <li><input checked="" type="checkbox"/> <b>DGLAS-H</b> Tempered door glass</li> <li><input type="checkbox"/> <b>DGLAS-L</b> Laminated door glass. A laminated safety glass can crack, but retains its protective effect for much longer. This means reduced risk of injury in case of an accident. This glass also provides better sound insulation. The laminated door glass is tinted and has a water repellent treatment.</li> <li><input checked="" type="checkbox"/> <b>LOCK-REM</b> Central door locking with remote control</li> <li><input checked="" type="checkbox"/> <b>BUMP-HD</b> Heavy duty front bumper</li> <li><input type="checkbox"/> <b>GUARD-EH</b> Guard plate for cooling pipes and oil sump</li> <li><input checked="" type="checkbox"/> <b>BUGNET</b> Radiator screen / Mosquito net (PVC coated fibreglass) in front of radiator</li> <li><input type="checkbox"/> <b>CTILT-P-E</b> Electrical cab tilt pump</li> <li><input checked="" type="checkbox"/> <b>CTILT-P-M</b> Manual cab tilt pump</li> <li><input type="checkbox"/> <b>FCABS-A</b> Air front cab suspension</li> <li><input checked="" type="checkbox"/> <b>FCABS-M</b> Mechanical cab suspension</li> <li><input type="checkbox"/> <b>RCABS-A</b> Air rear cab suspension</li> <li><input checked="" type="checkbox"/> <b>RCABS-M</b> Mechanical rear cab suspension</li> <li><input type="checkbox"/> <b>MIRCFCPX</b> Electrically heated and operated rear view mirrors with a wide angle section on both sides and kerb observation mirror on the passenger side. Passenger corner camera in the mirror bracket at the passenger side.</li> <li><input checked="" type="checkbox"/> <b>MIRCOMFX</b> EI heated &amp; operated robust main rear view mirrors, electrically heated wide angle mirrors (both sides). Close view mirror on passenger side.</li> <li><input checked="" type="checkbox"/> <b>AMIR-F20</b> Front close view mirror above windscreen, passenger side (radius 200 mm)</li> <li><input type="checkbox"/> <b>SUNV-H</b> Exterior transparent dark grey front sun visor</li> <li><input type="checkbox"/> <b>AD-ROOF</b> Roof air deflector. Design (length, height etc.) automatically calculated and varies depending on vehicle total height (chassis height, cab type, tyres etc).</li> <li><input type="checkbox"/> <b>AD-SIDES</b> Short cab side air deflectors</li> <li><input checked="" type="checkbox"/> <b>HL-BASIC</b> Halogen H7 head lamps</li> <li><input type="checkbox"/> <b>HL-BHID2</b> Bi-Xenon head lamps, high intensity discharged (heavy duty)</li> <li><input type="checkbox"/> <b>HL-CLEAN</b> The headlamp cleaner is a high-pressure washer unit with nozzles integrated at the side of the headlamp. It works during high- or low beam and it is activated when the windscreen wiper switch is turned on. The cleaner mainly cleans high- and low beam area</li> <li><input type="checkbox"/> <b>HLP-ST</b> Steel headlamp protection</li> <li><input type="checkbox"/> <b>HL-ADJ</b> The headlamp adjustment control is used to change the height of the light beam. If there is a big difference between the chassis inclination angle when loaded and unloaded, this optional feature can be operated to avoid dazzling other road users. The function is not needed when chassis height is adjusted via the air suspension system height control.</li> <li><input checked="" type="checkbox"/> <b>DRL-LED</b> V-shaped ("V-light") day running light (LED). Turned on low beam gives a dimmed "V-light".</li> <li><input type="checkbox"/> <b>ASL-RF2</b> Two Hella H11 70W spot lamps in sign box (one on each side of the Globetrotter sign)</li> <li><input type="checkbox"/> <b>ASL-RFPK</b> Preparation kit for two spot lamps in sign box</li> <li><input type="checkbox"/> <b>BEACOA2F</b> Two LED warning lights on the cab front</li> <li><input type="checkbox"/> <b>BEACOA2R</b> Two LED warning lights on the cab rear</li> <li><input type="checkbox"/> <b>BEACON-P</b> Preparation kit</li> <li><input type="checkbox"/> <b>BEACONA4</b> Four LED warning lights on the cab front-rear</li> <li><input checked="" type="checkbox"/> <b>CABPT-R1</b> One front cab roof pass through on passenger side</li> <li><input checked="" type="checkbox"/> <b>CABPT-R2</b> Two front cab roof pass throughs, one on each side</li> <li><input type="checkbox"/> <b>SPOTP-F</b> Spotlamp preparation in cab front, max 280W</li> <li><input type="checkbox"/> <b>SPOTP-R</b> Spotlamp preparation on cab roof, max 280W</li> </ul>
---	---

### Cab Exterior

- EXTL-BAS** NEW-HDV: Exterior trim level basic  
CLASS-HDV: Basic exterior finish in a lightning grey colour of cab surrounding parts (mirror housings, insteps, bumper and if fitted bumper spoiler and sun visor).

Standard Equipment       Optional Equipment

For more detailed information about cab and powertrain equipment, please refer to separate specification sheets.

For all possible options and combinations of options please consult your Volvo sales contact who can create a specification to match your requirements using the Volvo Sales Support system (VSS).

The factory reserves the right to modify design and change equipment without previous notification. The specification can vary from country to country.

# MODEL RANGE

## FMX LNG 64 Rigid Rear Air FMX 64R LA2

<input type="checkbox"/> <b>SPOTP-RF</b>	Spotlamp preparation on cab roof and in cab front, max 2x280W		Wiring harness routed from the bodybuilder electrical distribution box inside the cab to a connection point inside the right frame rail beside the gearbox.
<input type="checkbox"/> <b>ROS-IL</b>	Illuminated roof sign with switch in radio shelf. Switch for turning on/off.	<input type="checkbox"/> <b>BEPR-T2</b>	Body builder electrical software preparation for tipper with remote control
<input type="checkbox"/> <b>ROS-IL2</b>	Preparation kit for installing an illuminated roof sign*. It includes a prerouted cable harness, a switch and LED-lamps. The switch is connected in the radio shelf middle section. Switch cap with icon, are enclosed in cab. Lamps in sign are mounted. The stripe in the Globetrotter window is selected via the cab sign variants	<input type="checkbox"/> <b>EXSTER</b>	Support for external steering control via body builder module
<input type="checkbox"/> <b>ROS-ILP</b>	Wiring preparation kit (wires and switch) for cab sign or roof air deflector illumination	<input type="checkbox"/> <b>TD-BAS</b>	Trailer detection without LED sensor
<input type="checkbox"/> <b>CSGN-FMX</b>	FMX decal in the cab roof sign area	<input checked="" type="checkbox"/> <b>TD-LED</b>	Trailer detection with LED sensor
<input checked="" type="checkbox"/> <b>HORN-F1S</b>	One front mounted (behind grille) single tone air horn, Jericho. Operated by steering wheel buttons.	<input type="checkbox"/> <b>FBA-BTF</b>	Lower front body attachments for torsionally flexible platform body
<input type="checkbox"/> <b>HORN-R2S</b>	Two roof mounted single tone chromed air horns. Operated by steering wheel buttons.	<input type="checkbox"/> <b>FBA-BTSF</b>	Lower front body attachments for torsionally semi-flexible body (van or curtainsider)
<input type="checkbox"/> <b>ANT-CBR</b>	Right hand side roof mounted foldable antenna and cables for CB radio, single aerial.	<input type="checkbox"/> <b>HBA-FSFB</b>	Holes for body attachments, flexible/semi-flexible body
<input type="checkbox"/> <b>ACCBP-AP</b>	Front, middle & rear roof mounted accessory brackets	<input type="checkbox"/> <b>HBA-SB</b>	Holes for body attachments, stiff body
<input type="checkbox"/> <b>ACCBP-F</b>	Front roof mounted accessory bracket	<input type="checkbox"/> <b>RBA-T2</b>	Lower rear body attachments for helper frame
<input type="checkbox"/> <b>ACCBP-FM</b>	Front & middle roof mounted accessory brackets	<input type="checkbox"/> <b>CRANEPK1</b>	Crane plates mounted to frame, interface for crane capacity up to 10 ton meter
<input type="checkbox"/> <b>ACCBP-FR</b>	Front & rear roof mounted accessory brackets	<input type="checkbox"/> <b>CRANEPK2</b>	Crane plates mounted to frame, interface for crane capacity up to 20 ton meter
<input type="checkbox"/> <b>ACCBP-M</b>	Middle roof mounted accessory bracket	<input type="checkbox"/> <b>CRANEPK4</b>	Crane plates mounted to frame, interface for crane capacity up to 40 ton meter
<input type="checkbox"/> <b>ACCBP-R</b>	Rear roof mounted accessory bracket	<input type="checkbox"/> <b>AUXL-SPK</b>	Electrical preparation kit (wiring and a switch in dashboard) for snow plough lights. Preparation for installation of additional headlights and additional turning indicators.
<input type="checkbox"/> <b>ACCBP-RM</b>	Rear & middle roof mounted accessory brackets	<input type="checkbox"/> <b>TAILPRE2</b>	Tail lift preparation kit, wireless remote operation
<input type="checkbox"/> <b>REFS-TW</b>	Reflecting white cab side stripes by-packed in cab	<input type="checkbox"/> <b>TAILPREP</b>	Tail lift preparation kit, wire remote operation
<input type="checkbox"/> <b>REFS-TY</b>	Reflecting yellow cab side stripes by-packed in cab	<input type="checkbox"/> <b>AESW2</b>	Two Body builder bistable electrical switches (marked AUX1 / AUX2)
<b>Superstructure preparations</b>		<input type="checkbox"/> <b>AESW2PK</b>	Two Body builder bistable electrical switches (marked AUX1/AUX2) and in an empty 4-group preparation another four bistable switches with dummy switch caps
<input type="checkbox"/> <b>SRWL-PK</b>	Wiring preparation for chassis mounted working lamps and a 3-position switch (On/Off/Reverse auto on).	<input type="checkbox"/> <b>AUXSW-4</b>	Wiring for 4 extra hardwired switches (from Body builder electrical centre to switch positions)
<input type="checkbox"/> <b>SWL-2FW</b>	Two white front chassis-mounted (LH/RH side) LED working lamps and a 2-position switch (On/Off).	<b>Services</b>	
<input type="checkbox"/> <b>SWL-2RW</b>	Two white rear chassis-mounted (LH/RH side) LED working lamps and a 2-position switch (On/Off).	<input checked="" type="checkbox"/> <b>TGW-4GWL</b>	Telematics gateway with 4G modem
<input type="checkbox"/> <b>SWL-4W</b>	Four white front (2) and rear (2) chassismounted (LH/RH side) LED working lamps and a 2-position switch (On/Off).	<input type="checkbox"/> <b>FMS-PK</b>	Fleet Management System gateway, preparation kit
<input type="checkbox"/> <b>SWL-PK</b>	Wiring preparation for chassis mounted working lamps and a 2-position switch (On/Off).	<input type="checkbox"/> <b>DRUT1</b>	My Truck connects the vehicle to the smartphone app, 1 year prepaid subscription
<input type="checkbox"/> <b>WL-CHPK</b>	Preparation kit (switch and cable) for working lamp, max 2x70 W. Connector on chassis at gearbox.	<input type="checkbox"/> <b>DRUT2</b>	My Truck connects the vehicle to the smartphone app, 2 year prepaid subscription
<input type="checkbox"/> <b>WLC-H2A</b>	Two H3/70W working lamps with amber coloured lens high mounted back of cab (switch incl).	<input type="checkbox"/> <b>DRUT3</b>	My Truck connects the vehicle to the smartphone app, 3 year prepaid subscription
<input type="checkbox"/> <b>WLC-H2W</b>	Two H3/70W working lamps, white lens high mounted back of cab (switch incl).	<input type="checkbox"/> <b>DRUT4</b>	My Truck connects the vehicle to the smartphone app, 4 year prepaid subscription
<input type="checkbox"/> <b>WLC-PKCH</b>	Preparation kit (cables and switch) for cab mounted chassis working lamp. Max load 280W.	<input type="checkbox"/> <b>DRUT5</b>	My Truck connects the vehicle to the smartphone app, 5 year prepaid subscription
<input type="checkbox"/> <b>WLC-PKH</b>	Preparation kit (cables and switch) for high mounted working lamps back of cab (pass through in cab rear roof included). Max load 280W.		
<input type="checkbox"/> <b>WLC-PKL</b>	Preparation kit (cables and switch) for low mounted working lamps back of cab (pass through in cab rear wall included). Max load 280W.		
<input type="checkbox"/> <b>WLC-PKLH</b>	Preparation kit (cables and switch) for low and high mounted working lamps back of cab (pass throughs in rear wall and rear roof included). Max load 280W.		
<input type="checkbox"/> <b>ECBB-BAS</b>	Body builder electrical centre without any body builder module		
<input type="checkbox"/> <b>ECBB-HIG</b>	Body builder electrical centre with cab body builder module, 14 high and 4 low dig. outlet		
<input checked="" type="checkbox"/> <b>ECBB-MED</b>	Body builder electrical centre with cab body builder module, 7 hig and 4 low dig. outlet		
<input type="checkbox"/> <b>BBCHAS1</b>	One 7-pole connector for Body builder interface. Wiring harness routed from the bodybuilder electrical distribution box inside the cab to a connection point inside the right frame rail beside the gearbox.		
<input type="checkbox"/> <b>BBCHAS3</b>	Three 7-pole connectors for Body builder interface.		

■ Standard Equipment

Optional Equipment

For more detailed information about cab and powertrain equipment, please refer to separate specification sheets.

For all possible options and combinations of options please consult your Volvo sales contact who can create a specification to match your requirements using the Volvo Sales Support system (VSS).

The factory reserves the right to modify design and change equipment without previous notification. The specification can vary from country to country.



# MODEL RANGE

FMX LNG 64 Rigid Rear Air FMX 64R LA2

---

Volvo Trucks. Driving Progress