

MODEL RANGE

FMX11 6x4 Rigid Air Suspension FMX 64R 1A

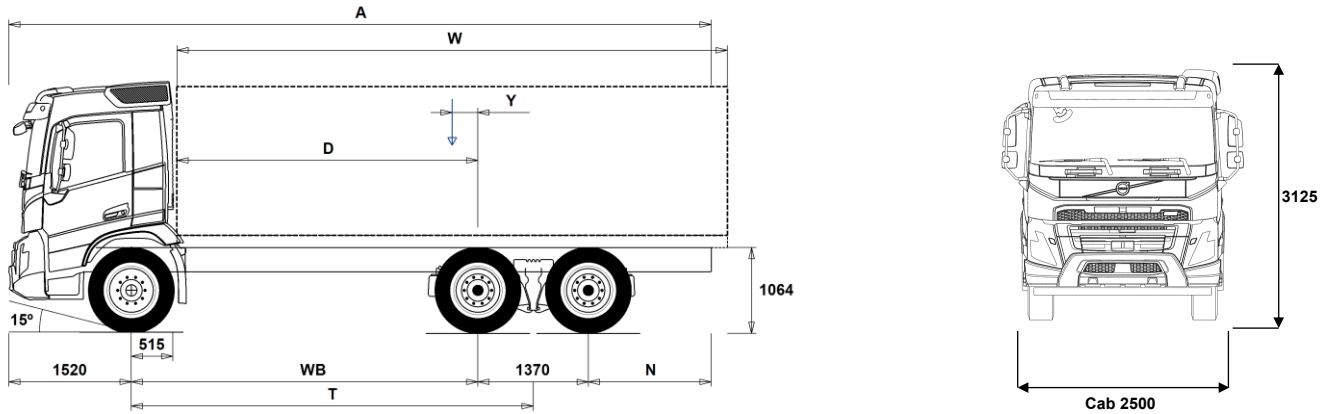

Chassis Dimensions [mm]

WB Wheelbase	3200	3400	3700	3900	4600	4900
A Overall Chassis Length	7865	7465	8615	8915	10715	10465
D Center of rear axle to front of body	2635	2835	3135	3335	4035	4335
N Rear Overhang (Min.)	825	825	825	825	825	825
N Rear Overhang (Max.)	1775	1175	2025	2125	3225	2675
T Theoretical Wheelbase	3885	4085	4385	4585	5285	5585
Y Center of Gravity for Payload (Min.)	-197	-182	-137	-113	-22	2
Y Center of Gravity for Payload (Max.)	-197	-182	-137	-113	-22	2
W Body Length (Min.)	5651	5971	6451	6771	7891	8371
W Body Length (Max.)	5651	5971	6451	6771	7891	8371

Chassis Weights [kg]

Front Axle	4615	4650	4630	4640	4645	4680
Rear Bogie	3380	3330	3415	3425	3575	3530
Kerb Weight	7995	7980	8045	8065	8220	8210
Payload (including body, driver, fuel, etc.)	15005	15020	14955	14935	14780	14790

Turning Diameter [mm]

Turning Circle Diameter Kerb to Kerb	13900	14500	15500	16100	18200	19100
Turning Circle Diameter Wall to Wall	15400	16000	16900	17600	19700	20600

Plated Weights [kg]

	Plated	Design
Gross Vehicle Weight	23000	28100
Gross Combination Weight	40500	44000
Front Axle	6500	7100
Rear Bogie	16500	21000

Important Notes

Chassis Dimensions

Cab Height: +328 mm for CAB-HSLP, -262 mm for CAB-LDAY, -262 mm for CAB-LSLP, +16 mm for CAB-SLP.
 Front Axle to Back of Cab: +431 mm for CAB-HSLP and CAB-SLP, -69 mm for CAB-LDAY, +425 mm for CAB-LSLP.
 D-measure includes a front clearance of 50 mm and for rigid trucks also a subframe of 100 mm.
 Height can vary ± 20 mm for leaf and ± 10 mm for air suspension.
 All dimensions are for unladen chassis and any tag axles down. Chassis height used: CHH-HIGH.
 Rear overhang used for vehicle weight calculation is the maximum rear overhang (N Max.) for selected wheelbase.
 Height change when chassis height CHH-MED,FRAME300: 0 mm.

Weight and dimensions are based upon the following tyres:
 Front Axle Tyres: 315/80R22.5
 Drive Axle Tyres: 315/80R22.5

Chassis weight includes oil, water, AdBlue, 0 litres fuel and without driver. Kerb weight can vary ± 3%.

Turning diameters are theoretically calculated.

Legal weights can differ from country to country.

For more detailed weight information, including optional equipment weights, ask your Volvo sales contact to enter your specification into the Volvo Weight Information system (WIS).

Do NOT use this drawing for bodybuilding. Refer to Volvo Bodybuilder Instructions and chassis assembly drawing FMX64R1A.

MODEL RANGE

FMX11 6x4 Rigid Air Suspension FMX 64R 1A

Truck use

- TIPP-PRE** Tipper preparation
- UNIFORM** Basic uniform vehicle

Core components

- CHH-HIGH** Chassis Height (high) approx. 1025-1050mm (depending on tyre selection)
- CHH-XHIG** Chassis Height (extra high) approx. 1100-1162mm (depending on tyre selection)
- RADD-G2** Rear air suspension-high clearance
- RADD-GR** Rear air suspension
- FMX-DAY6** Day Cab
- FMX-HSL6** Globetrotter Cab
- FMX-LDA6** Low Day Cab
- FMX-LSL6** Low Sleeper Cab
- FMX-SLP6** Sleeper Cab
- EU6SCR** Eu6 SCR (Particulate Filter + EGR) Single Stage Turbo
- D11S380A** Eu6 Fuelface 11 litre 380hp Engine
- D11S430A** Eu6 Fuelface 11 litre 430hp Engine
- D11S460A** Eu6 Fuelface 11 litre 460hp Engine
- D11K380** Eu6 11 litre Engine 380hp/1800nm/280kW
- D11K430** Eu6 11 litre Engine 430hp/2050nm/317kW
- D11K460** Eu6 11 litre Engine 460hp/2200nm/339kW
- EBR-VEB** Volvo Engine Brake (VEB)
- AT2612** Volvo I-shift-12 Speed Automatic Transmission (2600nm)
- PT2106** Powertronic 6 Speed Transmission (2100nm)
- RTH2610B** Volvo RTH2610B hub reduction rear axles
4 planet gears per hub
Axle rating: 26,000 kg
115 tonne train weight
(Application approved)
- RTS2370B** Single Reduction Tandem 23t GCW70t

Packages

- INFOHIGH** High Level Information Platform

Chassis

- FST-AIR** Air Bag Front Suspension
- FST-PAR** Parabolic leaf spring front suspension
- FST-PAR3** 3 Leaf Parabolic Front Springs (stiffer than normal)
- FSL5-BAS** Front Suspension Levelling Stroke - Standard
- FAL6.5** Front Axle Load 6.5 tonnes
- FAL7.1** Front axle load 7.1 tonnes
- FAL7.5** Front Axle Load 7.5 tonnes
- FAL9.0** Front axle load 9.0 tonnes
- FSTAB** Front stabilizer, normal stiffness
- FSTAB2** Front stabiliser bar increased stiffness
- FSTAB3** Heavy duty front stabiliser bar
- RAL21** Rear suspension load rating: 21,000 kg
- RAL26** Rear suspension load rating: 26,000 kg
- RSTAB3** Heavy duty rear stabiliser bar
- ACTST-TO** Volvo Dynamic Steering
- ASFE-PO** Dynamic Steering Active Features - Personal Settings & Oversteer Guidance
- ASFE-PS** Dynamic Steering Active Features - Personal Settings
- PSP-VAR** Power Steering Pump with Variable Displacement
- PSP-VAR2** Power Steering Pump with Electronic Control Variable Displacement
- EBS-MED** Electronic Brake System (EBS) contains
ABS, Traction control, Hill start aid
Diff lock control, Brake assist
Wheel brake monitoring, EBS status
- AUXPARK** Auxiliary parking brake
- FST7070** Frame Section Thickness 7mm

- FST8080** Frame Section Thickness 8mm
- FIL-EEEF** Liner (inner) from end of engine to end of frame
- FIL-FBEB** Liner (inner) - front of bogie to end of bogie
- FIL-FBEF** Liner (inner)- front of bogie to end of frame
- FIL-TXEB** Liner (inner) - trans x-mem to end of bogie
- FIL-TXEF** Liner (inner) - trans x-mem to end of frame
- BBOX-L** Battery box mounted on LHS chassis rail
- 2BATT225** 2x225 Ah batteries
- BATTAMP** Battery Amperage Indicator (in the DID)
- MSWI-C** Isolation Toggle Switch LHS of Chassis
- MSWI-R** Isolation Switch on Key Fob (Press Door Lock Twice to Isolate)
- R345A71** RHS 345 litre Alloy Fuel Tank
Min volume 345l
Max volume 465l
- UL-FUEL** LHS fuel tank not fitted
Min volume 195l
Max volume 195l
- ADTP-L** AdBlue Tank Position - LHS
- ADB064** AdBlue Tank 64 litres
- ADB090** AdBlue Tank 90 litres
- FCAP-L** Fuel tank cap with lock
- ESH-REAR** Low Mounted Muffler with Low Rear Facing Outlet
- ESH-RIGH** Muffler horizontal, right exhaust outlet
- ESH-VERT** Muffler horizontal, vertical exhaust outlet on right hand side
- EXST-SSP** Stainless Steel Exhaust Stack
- TRBR-HCR** Hand controlled trailer brake, reduced pressure
- TRBR-STA** Stationary trailer brake control
- TRB-STRE** Automatic trailer brake activation (stretch brake)
- TL-LED** LED tail lights
- BLIGHT-E** Emergency Brake Lights

Rims and Tyres

- RT-AL** 10 stud alloy disc rims (with long wheel studs)
- RT-ALDP** 10 stud dura-bright alloy disc rims (with long wheel studs)
- RT-ALDPD** 10 stud dura-bright alloy disc rims (with short wheel studs)
- RT-ALDU** 10 stud alloy disc rims (with short wheel studs)
- RT-ALP** 10 stud polished alloy disc rims (with long wheel studs)
- RT-ALPDU** 10 stud polished alloy disc rims (with short wheel studs)
- RT-STEEL** 10 stud steel disc rims
- SPWT-D** Spare rim & tyre equal to drive
- SPWT-F** Spare rim & tyre equal to steer
- SWCP-T2** Transport mounted spare wheel
- JACK-12T** 12 tonne capacity jack with brace
- JACK-15T** 15 tonne capacity jack and brace
- TOOL-BAS** Basic tools
- TOOLKIT** Tool kit complete
- INFLAHOS** Tyre inflation hose (18 metres)

Powertrain equipment

- TRAP-HD** Heavy Duty Transmission Internals
- DRM-BE** Drive Mode - Balanced & Economy
- DRM-E** Drive Mode - Economy
- PVT-MAP** Preview Topography Information (high resolution commercial topography map)
- CRUIS-E** Extended cruise control (additional fuel saving functions)
- AMSO-AUT** Manual gear shift in automatic mode.
- AVO-ENH** AMT Vocational option - enhanced
- APF-ENH** Enhanced I-shift PTO functions
- CS43B-O** Volvo 430mm single plate clutch

- Standard Equipment
- Optional Equipment

For more detailed information about cab and powertrain equipment, please refer to separate specification sheets.

For all possible options and combinations of options please consult your Volvo sales contact who can create a specification to match your requirements using the Volvo Sales Support system (VSS).

The factory reserves the right to modify design and change equipment without previous notification. The specification can vary from country to country.

MODEL RANGE

FMX11 6x4 Rigid Air Suspension FMX 64R 1A

- TC-HWO** Transmission Oil Cooler
- TC-MAOH2** High performance transmission cooler
- 2COM1100** Air compressor. 1100 litres/minute (Eu6)
- 2COMP870** Air compressor. 870 litres/minute (Eu6)
- AIRIN-HI** High air intake, roofline position
- AIRIN-LO** Low air intake, rear of cab position
- ACL1ST-S** Air cleaner with two stage filter element
- 24A110BL** Alternator - 110 Amp (Eu6)
- 24A150BL** Alternator - 150 Amp (Eu6)
- PTER-100** PTO engine rear mounted with flange DIN100/ISO7646
- PTER-DIN** Power Take Off / splined shaft groove (female) DIN5462.
- PTER1400** Rear engine mounted power-take-off with flange SAE 1410
- HPE-F101** F1-101 Hydraulic pump rear engine mounted
- HPE-F41** F1-41 Hydraulic pump rear engine mounted
- HPE-F51** F1-51 Hydraulic pump rear engine mounted
- HPE-F61** F1-61 Hydraulic pump rear engine mounted
- HPE-F81** F1-81 Hydraulic pump rear engine mounted
- HPE-T53** F2-53/53 twin flow hyd pump rear engine mounted
- HPE-T70** F2-70/53 twin flow hyd pump rear engine mounted
- HPE-V45** V1-45 variable pump rear engine mounted
- HPE-V75** V1-75 variable pump rear engine mounted
- PTPT-D** PTO DIN / Powertronic
- PTPT-F** PTO flange conn / Powertronic
- PTR-D** Low speed PTO with DIN connection
- PTR-DH** High speed PTO with DIN connection
- PTR-DM** Medium speed PTO with DIN connection
- PTR-F** Rear PTO trans.flange 100% speed
- PTR-FH** High speed PTO with flange connection
- PTR-FL** Low speed PTO with flange connection
- PTRD-D** PTO with 2 DIN connections rear + 1 DIN connection front
- PTRD-D1** PTO with 1 DIN + 1 flange connection rear + 1 DIN connection front
- PTRD-D2** PTO with 2 flange connection rears + 1 DIN connection front
- PTRD-F** PTO with 1 DIN + 1 flange connection rear
- HPG-F101** F1-101 hydraulic pump gearbox mounted
- HPG-F41** F1-41 hydraulic pump gearbox mounted
- HPG-F61** F1-61 hydraulic pump gearbox mounted
- HPG-F81** F1-81 hydraulic pump gearbox mounted
- DRC-AMMI** DPF regeneration- auto initialise/manual on demand/manual inhibit
- DRC-AUTO** DPF regeneration- fully automatic (in motion)
- ESP-BAS1** ESP package (tractor/trailer combinations with ABS/EBS Or Rigid with standard COG)
- HWSS-ACB** ACC & forward collision warning & emergency braking.
- HWSS-FCB** Forward Collision Warning including Emergency Braking
- LSS-DW** With lane departure system
- LSS-DW3** Pilot Assist - Active Continuous Lane Keeping
- LCS2** Lane Change Support with Side Collision Avoidance (LHS)
- DAS-W** Driver alert support warning
- RENS-W** Rain sensor to activate wipers
- CU-ECC** Climate controlled air conditioning
- CU-MCC** Manual controlled air conditioning
- IGT-BUT** Ignition Type - Push Button
- IMMOBIL** Engine immobiliser
- ALARM-B** Anti-theft alarm (cab)
- ISUNS-DS** Interior side sunvisor - driver's door
- ISUNF-B** Interior front sunvisor - standard
- ISUNF-MD** Interior front sunvisor - with mirror (driver's side)
- ISUNF-RE** Interior sunvisor - front (electric)
- ISUNF-RM** Interior sunvisor - front (manual)
- ADFS** 2 din slots in front shelf
- BUPALARM** Reverse alarm
- LOADIND** Load indicator, electronic controlled suspension (SUSPL-EC)
- REMC-MF** Multifunction wireless remote control
- FIREX25A** Fire extinguisher 2.5 kg
- WRITEPAD** Storable steering wheel fit clip board
- DST-CF5** Fully adjustable driver's comfort seat
Air suspension, heated, integrated safety belt
- SBD-RED** Red safety belts, pass. & driver seats
- SBPRE-DS** Drivers seat belt pretensioner
- PST-BAS1** Basic passenger's seat
- PST-CF5** Fully adjustable passenger comfort seat
Air suspension, heated, safety belt
- SBPRE-PS** Passenger seatbelt pretensioner
- ARMRE-BB** Armrests both sides - driver's & passenger's seat
- ARMRE-DB** Armrests both sides - driver's seat
- ARU-BAS** Seat armrest upholstery - basic
- FMAT-RUB** Floor mats - rubber
- FMAT-TX2** Floor mats - textile & rubber
- LBK70** Lower bunk 700mm wide
- MATL-FI** Spring Mattress Lower Bunk - Firm (100kg +)
- MATL-SF** Mattress lower bunk - semi firm
- OLMAT-BA** Mattress overlay - basic
- TBK70F** Top bunk 700mm wide, foldable
- SAFE** Safe box at bed-end
- ETSB-F** Engine tunnel storage box
- ETSB-FR** Engine tunnel storage box & rear cab wall
- ETSB-R** Rear cab wall storage
- RUS-BAS** Rear upper cab storage - 154 litres for Sleeper/Globetrotter & 60 litres for Day Cab
- RUS-HIG** Rear upper cab storage - 245 litres
- TABLE** Table
- REF-ICPK** Refrigerator prep kit (on engine tunnel)
- REFR-RUS** 28 litre refrigerator in upper rear storage
- MICRO-PK** Prep kit for microwave
- BOTH-D** Bottle holder in driving area
- INLI-BAS** Interior night lights
- INLI-NL** Interior white and red (night) light
- INLI-NLD** Interior light including night light and dimmer function
- ARL-FLEX** Flexible reading lamp (snake light)
- RH-ER** Roof hatch-electric (metal emergency exit)
- RH-MTR** Roof hatch-manual (tinted glass & rear opening)
- SWIND-PS** Cab passenger side aux. window
- AWIND-RF** Cab rear window- fitted
- VANMIR** Vanity mirror
- AS-FUS** Auxiliary shelf, front upper storage
- INFOT-PK** LCD screen mount - 6kgs max

Cab exterior

- EXTL-BAS** Standard exterior trim level
- DGLAS-H** Hardened door glass
- DGLAS-L** Laminated door glass
- BUMP-HD** Bumper - heavy duty
- AUXFS** Auxiliary folding side step
- GUARD-EH** Guard plate for cooling pipes and oil sump
- BUGNET** Insect net in front of radiator

Standard Equipment Optional Equipment

For more detailed information about cab and powertrain equipment, please refer to separate specification sheets.

For all possible options and combinations of options please consult your Volvo sales contact who can create a specification to match your requirements using the Volvo Sales Support system (VSS).

The factory reserves the right to modify design and change equipment without previous notification. The specification can vary from country to country.

MODEL RANGE

FMX11 6x4 Rigid Air Suspension FMX 64R 1A

- **CTILTP-E** Electrical cab tilt pump
- **FCABS-A** Front cab suspension-air bellows
- **FCABS-M** Front cab suspension-mechanical spring
- **RCABS-A** Rear cab suspension-air bellows
- **RCABS-M** Rear cab suspension-mechanical spring
- **MIRFLACP** Electrically heated & operated flat glass mirrors with front monitoring camera on passenger side.
- **AMIR-F20** Close view mirror
- **SUNV-H** Exterior sunvisor
- **AD-ROOF** Aero-dynamic roof mounted deflector
- **AD-SIDES** Aero-dynamic cab side deflectors
- **GUARD-W** Windscreen stoneguard
- **HL-BASIC** Standard head lamps
- **HL-LED** LED headlights
- **HBDA-A** Automatic High Beam De-Activation
- **HL-CLEAN** Head lamp cleaning system
- **HLP-ST** Headlamp protection-steel
- **HLP-ST2** Headlamp protection-steel/wire mesh (non ADR compliant)
- **HL-ADJ** Headlight adjustment - manual
- **DRL-LED** V-shaped LED daytime running light
- **ASL-RF2** Spotlights inside Globetrotter Sign Box
- **IDLAMP-A** Identification lamps-amber
- **BEACON-P** Beacon light wire preparation
- **SPOTP-F** Aux spotlamp preparation, 280W maximum
- **CSGN-FMX** Globetrotter - FMX decal
- **ANT-CBR** Antenna for CB radio, single antenna

Superstructure

- **SRWL-2RW** 2 white rear chassis mounted working lamps
- **SRWL-PK** Wiring prep for chassis mounted reverse/working lamps-3 position switch
- **SWL-2FW** 2 white side working lamps (forward facing)
- **SWL-2RW** 2 white side working lamps (rearward facing)
- **SWL-4W** 4 white side working lamps
- **SWL-PK** Wiring prep for chassis-mounted working lamps-2 position switch
- **WL-CHPK** Chassis mounted working lamp prep kit
- **WLC-H2W** 2 LED work lamps - high mounted with white lens.
- **WLC-PKH** Prep kit for high mounted work lamps.
- **ECBB-HIG** Body builder module - cab module
- **ECBB-MED** Body builder module - cab module
- **BBCHAS3** Body builder chassis electrical interface, 3 x 7 pin connectors
- **EXSTER** External steering via body builder's module
- **HBA-SB** Holes for body attachments
- **AESW2** 2 flexible switches (AUX1 and AUX2).
- **AESW2PK** 2 flexible switches (AUX1 & AUX2) + additional 4 flexible switches
- **AUXSW-4** Wiring prep. for 4 extra bodybuilder switches (switches not included)

Delivery services

- **TGW-4GWL** Telematics Gateway with 4G/LTE & WLAN
- **FMS-PK** Fleet management system gateway
- **DRUT2** "My Truck" Smartphone App. 2 Year Prepaid