

MODEL RANGE

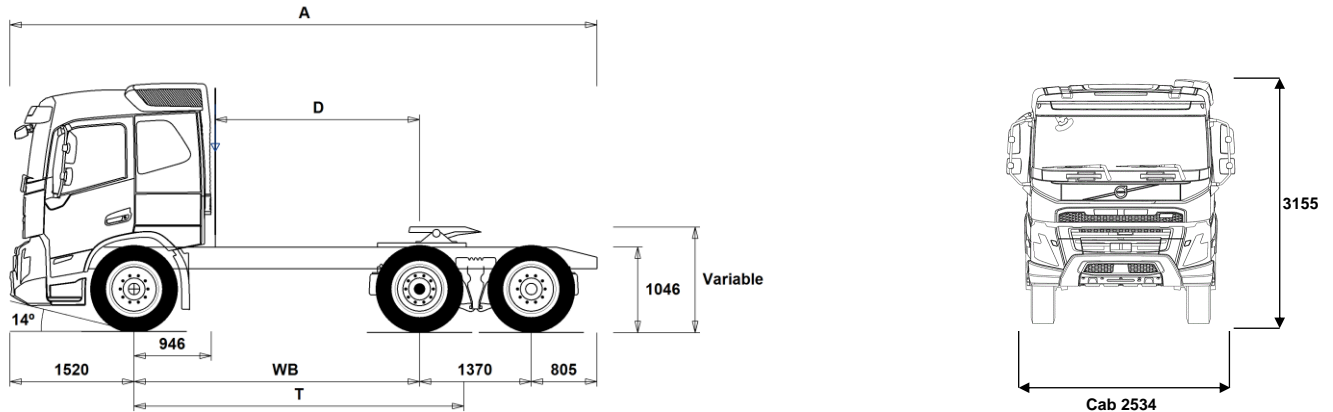

Volvo Trucks. Driving Progress

NEW FMX 13 6x2 Tag Tractor - Rear Air Suspension FMX 62T T3A



Chassis Dimensions [mm]

WB Wheelbase	3000	3200	3400	3900
A Overall Chassis Length	6695	6895	7095	7595
D Center of rear axle to back of cab	2004	2204	2404	2904
T Theoretical Wheelbase	3541	3741	3941	4441

Chassis Weights [kg]

Front Axle	4155	4200	4245	4330
Rear Bogie	3410	3380	3360	3310
Kerb Weight	7565	7580	7605	7640

Turning Diameter [mm]

Turning Circle Diameter Kerb to Kerb	12900	13500	14100	15600
Turning Circle Diameter Wall to Wall	14400	15000	15600	17100

Plated Weights [kg]

	Plated	Design
Gross Vehicle Weight	26000	26500
Gross Combination Weight	44000	44000
Front Axle	7500	7500
Rear Bogie	19000	19000

Important Notes

Chassis Dimensions

Cab Height: -16 mm for CAB-DAY, +312 mm for CAB-HSLP, -278 mm for CAB-LDAY, -278 mm for CAB-LSLP.

Front Axle to Back of Cab: -431 mm for CAB-DAY, -500 mm for CAB-LDAY, -6 mm for CAB-LSLP.

D-measure includes a front clearance of 50 mm and for rigid trucks also a subframe of 100 mm.

Height can vary ± 20 mm for leaf and ± 10 mm for air suspension.

All dimensions are for unladen chassis and any tag axles down. Chassis height used: CHH-HIGH.

Height change when chassis height CHH-MED,FRAME266: 0 mm.

Weight and dimensions are based upon the following tyres:

Front Axle Tyres:	315/80R22.5
Drive Axle Tyres:	315/80R22.5
Trailing/Pusher Axle Tyres:	315/80R22.5

Chassis weight includes oil, water, AdBlue, 0 litres fuel and without driver. Kerb weight can vary $\pm 3\%$.

Turning diameters are theoretically calculated. Tag axle used: TA-FIXED.

Legal weights can differ from country to country.

For more detailed weight information, including optional equipment weights, ask your Volvo sales contact to enter your specification into the Volvo Weight Information system (WIS).

Do NOT use this drawing for bodybuilding. Refer to Volvo Bodybuilder Instructions and chassis assembly drawing FMX62TT3A.

MODEL RANGE

NEW FMX 13 6x2 Tag Tractor - Rear Air Suspension FMX 62T T3A

TRUCK USE

- RC-ROUGH** Road conditions - On / off-road
- RC-SMOOTH** Road Conditions - Smooth

CORE COMPONENTS

- CHH-HIGH** Chassis Height - High - for loading heights check the unique BEP chassis drawing
- CHH-MED** Chassis Height - Medium - for loading heights check the unique BEP chassis drawing
- TAG-FIXD** Tag axle - Fixed with twin tyres on tag axle
- TAG-FIXS** Tag axle - Fixed with single tyres on tag axle
- RADT-GR** Rear air suspension, 2 axles - 1 driven/1 tag
- FMX-DAY5** Cab - Day - with steel safety cage design
Designed and built to Swedish impact and ECE R29 regulations
- FMX-HSL5** Cab - Globetrotter - with steel safety cage design
Designed and built to Swedish impact and ECE R29 regulations
- FMX-LDA5** Cab - Low Day - with steel safety cage design
Designed and built to Swedish impact and ECE R29 regulations
- FMX-LSL5** Cab - Low Sleeper - all-steel safety cage design.
Built to Swedish impact and ECE R29 regulations
- FMX-SLP5** Cab - Sleeper - with steel safety cage design
Designed and built to Swedish impact and ECE R29 regulations
- EU6SCR** Emission level - Euro VI step E
- D13 420S** Engine - D13K420 12.8 litre developing 420hp at 14-1800rpm.
Peak torque 2100Nm at 860 -1400rpm.
- D13 460S** Engine - D13K460 12.8 litre developing 460hp at 14-1800rpm.
Peak torque 2300Nm at 900-1400rpm.
- D13 500S** Engine - D13K500 12.8 litre developing 500hp at 14-1800rpm.
Peak torque 2500Nm at 1000-1400rpm.
- D13 540S** Engine - D13K540 12.8 litre developing 540hp at 14-1800rpm.
Peak torque 2600Nm at 1000-1450rpm.
- D13K420** D13K420 - 420hp engine
- D13K460** D13K460 - 460hp engine
- D13K500** D13K500 - 500hp engine
- D13K540** D13K540 - 540hp engine
- EBR-EPG** Engine Brake Type - Exhaust brake controlled by steering column switch
- EBR-EPGC** Engine Brake Type - Exhaust pressure governor for I shift gearbox
- EBR-VEB+** Engine Brake Type - Volvo engine brake + and exhaust pressure governor, enhanced performance from additional exhaust rocker control. Retardation 375kW
- AT2612F** Gearbox - AT2612F 12-speed "I-shift" automated mechanical suitable for gross train weights up to 60tonne only.
Refer to sales engineering when used in conjunction with a PTO
- ATO2612F** Gearbox - ATO2612F 12-speed "I-shift" overdrive automated mechanical, suitable for gross train weights up to 60tonne.
Refer to sales engineering when used in conjunction with a PTO
- PT2606** Gearbox - Powertronic automatic 6-speed, max. engine torque 2600 Nm, max. permitted GCW 130000 kg
- SPO2812** Gearbox - SPO2812 - 12-speed I-shift Dual Clutch automated mechanical GCW 60tonne
- ASO-C** Crawler gear -
Ratio direct top gearbox 19:1
Ratio Overdrive gearbox 17:1
- ASO-ULC** Ultra low crawler and crawler gear -
Ratios direct top gearbox 32:1 and 19:1
Ratios Overdrive box 32:1 and 17:1
- RSH1370F** Drive Axle - RSH1370F 13-tonne hub reduction with differential lock - design GCW 70 tonne
- RSS1344E** Drive Axle - RSS1344E single reduction with differential lock - design GCW 44 tonne

- RSS1352A** Drive Axle - RSS1352A single reduction 13 tonne with differential lock - design GCW 52 tonne
- RSS1370A** Drive Axle - RSS1370A single reduction 13 tonne with differential lock - design GCW 70 tonne
- RSS1370B** Drive Axle - RSS1370B single reduction 13 tonne with differential lock - design GCW 70 tonne

PACKAGES

- FUELPACK** Long Haul Fuel Economy driving package
- DRIVE5** Drive Package
- DRIVE5+** Drive+ Package
- DRIVE5++** Drive++ Package
- 1LIVINFM** Sleep & Resting Package - Living one-bed
- 2LIVINFM** Sleep & Resting Package - Living two-bed
- INFOBAS** Basic media package without secondary display
- INFODF** Media Information Platform with Dynafleet Support
- INFOMED** Media Information Platform - Medium level
- INFONAV** Media Information Platform with Navigation
- INFONDF** Media Information Platform with Navigation & Dynafleet Support
- VISIX5** Visibility Package
- SAFE-VE** Active Safety Package
- SAFE-VE+** Active Safety+ Package

CHASSIS

- FST-AIR** Front suspension type - Air
- FST-PAR** Front suspension type - 2 leaf parabolic springs
- FST-PAR3** Front suspension type - 3 leaf parabolic springs
- FSL5-BAS** Front suspension levelling - basic stroke
- FSL5-HI** Front suspension levelling - high stroke for demount operations - check with bodybuilder
- FAL10.0** Front axle design capacity - 10 tonne - check tyre capacity
- FAL7.5** Front axle design capacity - 7.5 tonne
- FAL8.0** Front axle design capacity - 8.0 tonne - check tyre capacity
- FAL8.5** Front axle design capacity - 8.5 tonnes
- FAL9.0** Front axle design capacity - 9.0 tonne - check tyre capacity
- FSTAB** Front anti-roll bar - Normal stiffness
- FSTAB2** Front anti-roll bar - Medium stiffness
- FSTAB3** Front anti-roll bar - High stiffness
- RSL5-BAS** Rear air suspension basic levelling stroke
- RAL19** Rear bogie design capacity - 19 tonne
- RAL20.5** Rear bogie design capacity - 20.5 tonne
- RAL22.5** Rear bogie design capacity - 22.5 tonne
- RSTAB1** Rear anti-roll bar - Normal stiffness
- RSTAB2** Rear anti-roll bar - Medium stiffness
- RSTAB3** Rear anti-roll bar - Stiff
- RALIM10** Rear-axle load limiter - 10 tonne
- RALIM105** Rear-axle load limiter - 10.5 tonne - speed controlled
- RALIM115** Rear-axle load limiter -11.5 tonne - speed controlled
- RALIM95** Rear-axle load limiter - 9.5 tonne
- ASF-DL1** Air suspension with 1 driving level
- ACTST-TO** Active Steering- Volvo Dynamic Steering - VDS - with extra electronic pump and torque overlay
- ASFE-BAS** Active steering feature - Basic - Volvo Dynamic Steering - VDS - only
- ASFE-OG** Active steering feature - Volvo Dynamic Steering - VDS - with stability assist - oversteer
- ASFE-PO** Active steering feature - Volvo Dynamic Steering - VDS - with personal settings and stability assist
- ASFE-PS** Active steering feature - Volvo Dynamic Steering - VDS - with personal settings
- PSS-SING** Power steering system - Single
- PSP-FIX** Power steering pump - Fixed displacement
- PSP-VAR** Power steering pump - Variable displacement
- EBS-MED** Brake package - EBS medium including "hill" hold function

- Standard Equipment
- Optional Equipment

For more detailed information about cab and powertrain equipment, please refer to separate specification sheets.

For all possible options and combinations of options please consult your Volvo sales contact who can create a specification to match your requirements using the Volvo Sales Support system (VSS).

The factory reserves the right to modify design and change equipment without previous notification. The specification can vary from country to country.

MODEL RANGE

NEW FMX 13 6x2 Tag Tractor - Rear Air Suspension FMX 62T T3A

- **RST-AIR** Rear suspension type - Air
 - **RST-AIR4** Rear suspension type - Air with reinforced air bellows
 - **SUSPL-EC** Remote electronic control on wander-lead for air suspension levelling
 - **FRAME266** Chassis frame section external height - 266 mm
 - **FRAME300** Chassis frame section external height - 300 mm
 - **FST7070** Chassis frame thickness - 7 mm web and flange
 - **FST8080** Chassis frame thickness - 8 mm web and flange
 - **FIL-EEEB** Chassis frame inner liner - From the end of the engine to the end of the bogie
 - **FIL-TXEB** Chassis frame inner liner - From gearbox member to the end of the bogie
 - **BBOX-EF** Battery box position - End of the frame in rear overhang
 - **BBOX-L** Battery box position - Left hand side
 - **BATS-D** Dual energy battery system - 2 living batteries and 2 starter batteries.
 - **BATS-S** Single energy battery system (2 batteries)
 - **2BAT210B** Battery Capacity - 2 x 210 Ah - Gel type
 - **2BAT210C** Battery Capacity - 2 x 210 Ah - AGM Absorbent Glass-fibre Material type
 - **BATTAMP** Battery management - Voltage and current gauge
 - **BATTIND** Battery management - Charge indicator
 - **ADR2** ADR Adaptation - For transportation of dangerous goods on the road - Note does NOT include safe loading pass package if required this is quoted separately
 - **MSWI-A** Battery master switch - ADR switch circuit shut down
 - **MSWI-C** Battery master switch - Chassis mounted toggle by the battery box
 - **MSWI-R** Battery master switch - Key fob operated remote controlled
 - **R330A71** Right fuel tank - 330litre aluminium diameter 710mm
Min volume 150l
Max volume 810l
 - **UL-FUEL** Without left fuel tank
Min volume 160l
Max volume 770l
 - **ADTP-BC** AdBlue tank position - Behind and under the cab on the right-hand side
 - **ADTP-L** AdBlue tank position - Chassis mounted on the left-hand side
 - **ADTP-R** AdBlue tank position - Chassis mounted on the right-hand side
 - **ADB048** Plastic AdBlue tank - 48 litre
 - **ADB050** Plastic AdBlue tank - 50 litre under/behind the cab
 - **ADB064** Plastic AdBlue tank - 64 litre
 - **ADB068** Plastic AdBlue tank - 68 litre
 - **ADB090** Plastic AdBlue tank - 90 litre
 - **ADB100** Plastic AdBlue tank - 100 litre
 - **ADTC-BF** AdBlue tank cover with satin alloy look decorative cover
 - **FCAP-L** Diesel and AdBlue filler cap - Locking
 - **FUFF-AS** Fuel filler - Anti-spill device
 - **FUFF-ATS** Fuel filler - Anti-spill & anti-syphon device
 - **ESH-LEFT** Exhaust - Horizontal silencer - left outlet
 - **ESH-REAR** Exhaust - Horizontal silencer - rear outlet
 - **ESH-RIGH** Exhaust - Horizontal silencer - right outlet
 - **ESH-VERT** Exhaust - Horizontal silencer - vertical outlet
 - **EXST-SSP** Stainless steel exhaust stack - NOT polished
 - **EXST-ST** Steel exhaust stack
 - **WHC-FIX2** Wheel chocks - Two fixed design
 - **WHC-FOL2** Two foldable wheel chocks
 - **WHCP-F** Wheel chock carrier position - In the front part of the vehicle
 - **WHCP-M** Wheel chock carrier position - Middle part of the vehicle
 - **WHCP-T** Wheel chock carrier position - Outer luggage locker
 - **TB-L80** Toolbox 800 mm, left side
 - **TB-R80** Toolbox 800 mm, right side
 - **SUP-BAS** EC approved chassis side guards
 - **SUP-LOW** EC approved low chassis side guards
 - **CHAIN-S** Snow chains
 - **HOOK-SC** Snow chain hooks
 - **TOWF-HD1** Front towing device - One heavy-duty front towing device
 - **RFEC-B** Rear frame profile - Tapered
 - **TOWR-ONE** Towing hitch attached to rear crossmember
 - **TREL15** Trailer electrical connection - Single 15 pin - ADR certified
 - **TREL7** 7 pole - 24N trailer electrical suzie
 - **TREL7-7** Trailer electrical connection - 2 x 7 pin - 24N and 24S
 - **TBC-DUO** Duomatic type air line connectors
 - **TBC-EC** Trailer brakes with EC palm coupling connectors
 - **TBC-GBR** 'C' and 'CA' type air line connectors
 - **TRBR-HCF** Full pressure hand controlled trailer brake
 - **TRBR-STA** Stationary trailer brake control
 - **TRB-STRE** Stretch Brake - Automatic low speed trailer brake activation to avoid jack-knifing and improve steerability
 - **RFEND-B** Three piece EC approved rear mud wings and spray flaps
 - **RFH-BAS** Basic rear wing height
 - **RFH-HIG** High rear wing height - higher wing tops
 - **RFH-LOW** Lower rear wing height - shallower wing tops
 - **ATANK-AL** Air tanks - Aluminium
 - **ATANK-ST** Air tanks - Steel
 - **TL-LED** Rear lights - LED
 - **BLIGHT-E** Emergency brake light
- ### WHEELS & TYRES
- **RT-AL** Wheels - Alcoa brushed aluminium rims - standard holes for long stud fixing
 - **RT-ALDP** Wheels - Alcoa Dura-Bright aluminium rims - standard holes for long stud fixing
 - **RT-ALDPD** Wheels - Alcoa Dura-Bright EVO aluminium rims - countersunk holes for short stud fixing
 - **RT-ALDU** Wheels - Alcoa brushed aluminium rims - countersunk holes for short stud fixing
 - **RT-STEEL** Wheels - Steel rims
 - **WCAP** Aerodynamic hub caps
 - **SPWT-D** Spare wheel & tyre with rear tyre pattern
 - **SPWT-F** Spare wheel & tyre with front tyre pattern
 - **SWCP-LF** Spare wheel carrier on left side of chassis ahead of rear axle
 - **SWCP-RF** Spare wheel carrier on right side of chassis ahead of rear axle
 - **SWCP-T** Spare wheel supplied temporarily strapped to chassis
 - **SWCP-TP** Temporary spare wheel carrier on top of chassis frame
 - **JACK-12T** 12 tonne bottle jack
 - **JACK-15T** 15 tonne bottle jack
 - **JACK-20T** 20 tonne bottle jack
 - **TOOL-BAS** Basic Toolkit
 - **TOOLKIT** Complete tool kit
 - **INFLAHOS** Tyre inflation hose
 - **GAUGE-TP** Tyre pressure gauge
- ### DRIVELINE EQUIPMENT
- **TRAP-HD** Reinforced gearbox application
 - **DRM-BE** Balanced & Economy Drive Mode
 - **DRM-E** Economy Drive Mode
 - **PVT-MAP** I-See Predictive Cruise Control - using map based topography information
 - **CRUIS-E** Eco cruise control (with eco-roll and I-cruise, controls in steering wheel)

■ Standard Equipment

□ Optional Equipment

For more detailed information about cab and powertrain equipment, please refer to separate specification sheets.

For all possible options and combinations of options please consult your Volvo sales contact who can create a specification to match your requirements using the Volvo Sales Support system (VSS).

The factory reserves the right to modify design and change equipment without previous notification. The specification can vary from country to country.

MODEL RANGE

NEW FMX 13 6x2 Tag Tractor - Rear Air Suspension FMX 62T T3A

- | | |
|--|---|
| <ul style="list-style-type: none"> <input type="checkbox"/> CRUIS-E4 Eco fleet software - with cruise speed 85, I-See and push button I-shift. <input type="checkbox"/> CRUIS-E5 Eco torque software - Improved economy mode. Fuel economy optimized cruise control for I-Save ■ CRUISEC Cruise control, standard <input type="checkbox"/> AMSO-AUT Enhanced I-shift software with manual shift available in auto mode and kickdown facility on accelerator pedal <input type="checkbox"/> AVO-ENH I-Shift application software - for construction and off road applications <input type="checkbox"/> APF-ENH I-shift enhanced PTO functions <input type="checkbox"/> RET-TH Gearbox mounted retarder <input type="checkbox"/> RET-TPT Hydraulic Retarder for Powertronic gearbox <input type="checkbox"/> TC-HWO Transmission oil cooler - water to oil <input type="checkbox"/> TC-MAOH2 Extra high performance transmission oil cooler - air to oil with front mounted radiator <input type="checkbox"/> TC-MWO Basic transmission oil cooler - water to oil <input type="checkbox"/> 2COM1100 Air compressor - Two-cylinder 1100 litres per minute ■ 2COMP900 Air compressor - Two-cylinder 900 litres per minute <input type="checkbox"/> CLU-AIRC Clutchable air compressor ■ AIRIN-HI Air intake - Roof-mounted behind cab on the left-hand side <input type="checkbox"/> AIRIN-LO Low level air intake behind cab on left hand side <input type="checkbox"/> ACL1ST-S Air filter - two-stage element ■ 24AL110B Alternator capacity - 110 amp ■ 24AL120B Alternator capacity - 120 amp alternator ■ 24AL150B Alternator capacity - 150 amp <input type="checkbox"/> CCV-C Closed crankcase engine ventilation ■ CCV-OX Closed crankcase ventilation for cold markets ■ PRIM-EL Electrical priming pump <input type="checkbox"/> PRIM-MAN Manual priming pump <input type="checkbox"/> FUEQ-EH Fuel line electric heater <input type="checkbox"/> AF-R Hot fuel recirculation heated fuel filter ■ FUEFE2LW Large engine mounted dual fuel filter with water separator ■ FUEFE2SW Small engine mounted dual fuel filter with water separator <input type="checkbox"/> EST-AID Engine starting aid -Preheating element in the air inlet manifold <input type="checkbox"/> 220EBH15 220V/1.5Kw electric engine block heater <input type="checkbox"/> PTER-100 Engine power-take-off - Rear-mounted with DIN100/ISO7646 flange <input type="checkbox"/> PTER-DIN Engine power-take-off - Rear-mounted with DIN5462 (female) splined shaft for a close-coupled pump
Models with 3 steering axles will use this to drive the steering pump (AUXPSP) <input type="checkbox"/> PTER1400 Engine power-take-off - Rear-mounted with SAE 1410 flange <input type="checkbox"/> HPE-F101 Parker F1-101, engine mounted, fixed displacement, single flow, engine mounted hydraulic pump <input type="checkbox"/> HPE-F41 Parker F1-41, engine mounted, fixed displacement, single flow, engine mounted hydraulic pump <input type="checkbox"/> HPE-F51 Parker F1-51, engine mounted, fixed displacement, single flow, engine mounted hydraulic pump <input type="checkbox"/> HPE-F61 Parker F1-61, engine mounted, fixed displacement, single flow, engine mounted hydraulic pump <input type="checkbox"/> HPE-F81 Parker F1-81, engine mounted, fixed displacement, single flow, engine mounted hydraulic pump <input type="checkbox"/> HPE-T53 Parker F2-53/53, engine mounted, Fixed displacement, Twin flow engine mounted hydraulic pump <input type="checkbox"/> HPE-T70 Parker F2-70/35, engine mounted, Fixed displacement, Twin flow engine mounted hydraulic pump <input type="checkbox"/> HPE-V45 Parker VP1-45, variable displacement, single flow, engine mounted hydraulic pump <input type="checkbox"/> HPE-V75 Parker VP1-75, variable displacement, single flow, engine mounted hydraulic pump <input type="checkbox"/> PTPT-D Powertronic PTO, 1 front/upper DIN connection for plug-in pump (max. 850 Nm) <input type="checkbox"/> PTPT-F Powertronic PTO, 1 front/upper rear facing SAE flange conn. for prop shaft (max.850 Nm) | <ul style="list-style-type: none"> <input type="checkbox"/> PTR-D Gearbox PTO for plug-in pump, 0.71xeng speed <input type="checkbox"/> PTR-DH Gearbox driven high speed PTO for one plug-in hydraulic pump <input type="checkbox"/> PTR-DM Gearbox driven medium speed PTO for one plug-in hydraulic pump <input type="checkbox"/> PTR-F Gearbox driven PTO with rear flange connection <input type="checkbox"/> PTR-FH Gearbox driven high speed PTO with SAE drive flange <input type="checkbox"/> PTR-FL Gearbox driven low speed PTO with SAE drive flange <input type="checkbox"/> PTRD-D Gearbox driven HIGH SPEED PTO for two plug-in hydraulic pumps <input type="checkbox"/> PTRD-D1 PTRD-D1 Gearbox driven HIGH SPEED PTO (1 SAE flange & 1 plug-in hydraulic pump) <input type="checkbox"/> PTRD-D2 Gearbox driven HIGH SPEED PTO (2 SAE flanges & 1 plug-in hyd pump) <input type="checkbox"/> PTRD-F PTO with 1 DIN + 1 flange connection rear, manual gearbox <input type="checkbox"/> HPG-F101 Parker F1-101 gearbox mounted, fixed displacement, single flow, hydraulic pump <input type="checkbox"/> HPG-F41 Parker F1-41 gearbox mounted, fixed displacement, single flow, hydraulic pump <input type="checkbox"/> HPG-F51 Parker F1-51 gearbox mounted, fixed displacement, single flow, hydraulic pump <input type="checkbox"/> HPG-F61 Parker F1-61 gearbox mounted, fixed displacement, single flow, hydraulic pump <input type="checkbox"/> HPG-F81 Parker F1-81 gearbox mounted, fixed displacement, single flow, hydraulic pump ■ STWPOS-R Steering wheel position - RIGHT-HAND DRIVE <input type="checkbox"/> STWM-LE Leather steering wheel <input type="checkbox"/> STGW-AD2 Adjustable steering wheel with neck tilt ■ STGW-ADJ Adjustable steering wheel ■ AIRBAG SRS Driver's air bag <input type="checkbox"/> INST-BAS Basic level instruments ■ DRC-AMII DPF Regeneration control switch - for manual and switching off regeneration ■ 1DAYDIG2 Tachograph - Continental VDO 4.0 <input type="checkbox"/> ARSL Additional road speed limit - switch in dashboard ■ ESP-BAS1 Electronic Stability Control <input type="checkbox"/> ESPC-RO ESP (Electronic Stability Program) functionality control - Reduced / Off <input type="checkbox"/> HWSS-ACB Adaptive cruise control ACC with forward collision warning and AEBS advanced emergency brake system ■ HWSS-FCB Forward collision warning with AEBS advanced emergency brake system ■ LSS-DW Lane departure-warning system <input type="checkbox"/> LCS Lane change support <input type="checkbox"/> DAS-W Driver Alert Support system <input type="checkbox"/> RSENS-W Rain sensing windscreen wipers <input type="checkbox"/> CU-ECC Cab Climate Unit - Electrically controlled air conditioning with sun sensor <input type="checkbox"/> CU-ECC2 Cab Climate Unit - Electrically controlled air conditioning with a carbon filter, sun, mist, and air quality sensor ■ CU-MCC Cab Climate Unit - Manual air conditioning ■ IMMOBIL Thatcham H2 approved immobiliser <input type="checkbox"/> ALARM-E Enhanced vehicle alarm - Thatcham H1 approved - Cab plus external sensor for body/trailer <input type="checkbox"/> ALCOLOCK Alcolock <input type="checkbox"/> BUPMON Back up monitor - Digital reverse camera, parameter & lead supplied loose in cab. <input type="checkbox"/> PHONE-PK Telephone preparation kit (antenna, antenna attachm. cable incl.) <input type="checkbox"/> ISUNS-BS Side sun visor - Driver & passenger side ■ ISUNS-DS Side sun visor - Driver-side |
|--|---|

■ Standard Equipment

Optional Equipment

For more detailed information about cab and powertrain equipment, please refer to separate specification sheets.

For all possible options and combinations of options please consult your Volvo sales contact who can create a specification to match your requirements using the Volvo Sales Support system (VSS).

The factory reserves the right to modify design and change equipment without previous notification. The specification can vary from country to country.

MODEL RANGE

NEW FMX 13 6x2 Tag Tractor - Rear Air Suspension FMX 62T T3A

- ISUNF-B** Interior front sun visor without mirror
- ISUNF-MD** Interior front sun visor with mirror on driver side
- ISUNF-RE** Electrically operated textile interior sun blind
- ISUNF-RM** Manually operated textile interior sun blind
- ADFS** Two extra DIN slots in front shelf - can be fitted with card or drawer available as an accessory
- BUPALARM** Reverse alarm
- RTOLL-PK** Road toll PREPARATION kit for trucks operating with "Toll Collect" in Germany
- LOADIND** Load indicator with central dashboard display
- REMC-MF** Multi-functio wireless remote control
- FIREXT3S** Fire extinguisher - 3kg mounted on the seat base
- WARNVEST** High visibility warning vest - no sleeves
- AIDKIT** First aid kit - Legal demand for EU markets including delivery to EU bodybuilder
- AIDKIT1B** First aid kit - Legal demand for trucks transiting Germany
- WARNLAMP** Portable warning lamp
- LAMP-IN** Inspection lamp
- BULBKIT** Bulb and fuse kit
- WRITEPAD** Writing pad
- DST-CF4** Driver seat - Suspended, adjustable shock absorber, travel, backrest & lumbar controls - seatbelt mounted to the seat
- DST-CF5** Driver seat - Suspended with adjustable shock absorber, travel, backrest, lumbar & heat controls - seatbelt mounted to the seat
- DST-CF6** Driver seat - Suspended with adjustable shock absorber, travel, backrest, lumbar, heat and ventilation controls - seatbelt mounted to the seat
- SBD-RED** Seat belt colour - Red
- SBPRE-DS** Driver seat belt pretensioner
- PST-BAS1** Passenger seat - Fixed non suspended fold up with seatbelt mounted in cab
- PST-CF4** Passenger seat - Suspended, adjustable shock absorber, travel, backrest & lumbar controls - seatbelt mounted to the seat
- PST-CF5** Passenger seat - Suspended with adjustable shock absorber, travel, backrest, lumbar & heat controls - seatbelt mounted to the seat
- PST-STD2** Passenger seat - Fixed with backrest adjustment, non suspended with seatbelt mounted in cab
- PST-STD4** Passenger seat - Standard suspended with seatbelt mounted in cab
- SBPRE-PS** Passenger seat belt pretensioner
- ARMRE-BB** Armrests - Two on both driver & passenger seats
- ARMRE-DB** Armrests - Two on the driver seat
- ARMRE-PB** Armrests - Two on the passenger seat
- ARU-BAS** Armrest upholstery - Vinyl
- ARU-LEA** Armrest upholstery - Leather
- FMAT-RUB** Footwell floor mats - Rubber
- FMAT-TX2** Footwell floor mats - Two sets, Rubber and textile with an embossed pile supplied in the cab
- LBK70** Lower bunk 700 x2000 mm, fixed
- MATL-FI** Firm lower bunk pocket sprung mattress
- MATL-SF** Lower flexizone mattress - semi-firm, pocket springs up to 100kg - 16 stone
- OLMAT-BA** 35mm mattress overlay protector
- OLMAT-PR** 50mm premium mattress overlay protector
- TBK60F** Fixed foldable top bunk 600 x 1900mm
- TBK70F** Fixed foldable top bunk 700 x 1900mm
- PH-CAB2** 1.8kW Air to air night heater
- PH-ENGCA** Engine and cab night heater
- PH-SS** Short stop heater
- SLCP-BAS** Sleeper control panel - Basic with switches for interior light, night heater, roof hatch and door lock
- ETSB-F** Storage on engine tunnel - Central document box with two rear cup holders
- ETSB-FR** Storage on engine tunnel - Central document box with two rear cup holders & open storage pocket on cab rear wall
- ETSB-R** Storage on engine tunnel - Open storage pocket on cab rear wall
- RUS-BAS** Rear cab upper storage - 300 mm high
- RUS-HIG** Rear cab upper storage - 440 mm high - volume 245 litres
- REF-ICPK** Fridge: engine tunnel mounted preparation kit
- REFR-RUS** Fridge - 28 litre rear upper wall mounted with dividers
- MICRO-PK** Wiring preparation kit for microwave oven
- BOTH-D** One bottle holder under dashboard centre section
- COFMA-PK** Coffee maker, preparation kit.
- INLI-BAS** Interior white LED lights - basic
- INLI-NL** Interior white and red night LED light with no dimmer
- INLI-NLD** Interior white and red night LED light with dimmer
- ARL-FLEX** Two flexible reading lamps (snake lamps)
- RH-EE** Fixed tinted glass sky window with emergency exit
- RH-ER** Steel roof hatch - Electrically operated, rear opening with emergency exit
- RH-ETR** Tinted glass roof hatch - Electrically operated, rear opening with emergency exit
- RH-MTR** Tinted glass roof hatch - Manually operated, rear opening with emergency exit
- GLAS-TIN** Tinted windows.
- SWIND-BS** Extra side window on both sides behind "B" pillar
- SWIND-PS** Cab side window - Left side rear behind 'B' post
- AWIND-RF** Rear window
- VANMIR** Vanity mirror in front shelf
- AS-FUS** Extra shelf in front upper storage compartments
- INFOT-PK** Preparation kit for the mounting of a flat screen TV in cab above the driver's door, includes bracket, electrical and speaker connections

CAB EXTERIOR

- EXTL-BAS** Basic exterior finish - Satin Volvo badges, grey grille, instep, bumper, bumper spoiler, grille, door handles mirror housing and sunvisor if specified.
- DGLAS-H** Tempered door glass
- DGLAS-L** Laminated door glass
- LOCK-CTL** Door locks - Central locking with key
- LOCK-REM** Door locks - Remote central locking
- BUMP-HD** Heavy duty front bumper
- GUARD-EH** Engine guard to protect sump and engine hoses
- BUGNET** Insect screen in front of radiator
- CTILT-P-E** Electrically operated hydraulic cab tilt
- CTILT-P-M** Manually operated hydraulic cab tilt
- FCABS-A** Front cab suspension - Air
- FCABS-M** Front cab suspension - Mechanical spring
- RCABS-A** Rear cab suspension - Air
- RCABS-M** Rear cab suspension - Mechanical spring
- MIRCFCPX** Mirrors - Electrically heated and operated - FMX- main and wide-angle with manually adjusted kerb view mirror on the passenger side and position camera in nearside mirror arm. To increase direct vision to the side the main mirrors have no cowlings
- MIRCOMFX** Electrically heated and operated -FMX- main and wide-angle mirrors with manually adjusted passenger kerb mirror, to

Standard Equipment Optional Equipment

For more detailed information about cab and powertrain equipment, please refer to separate specification sheets.

For all possible options and combinations of options please consult your Volvo sales contact who can create a specification to match your requirements using the Volvo Sales Support system (VSS).

The factory reserves the right to modify design and change equipment without previous notification. The specification can vary from country to country.

MODEL RANGE

NEW FMX 13 6x2 Tag Tractor - Rear Air Suspension FMX 62T T3A

<ul style="list-style-type: none"> ■ MIRSTDX2 increase direct vision to the side the main mirrors have no cowlings Electrically heated -FMX- main and wide-angle mirrors with manually adjusted passenger kerb mirror, to increase direct vision to the side the main mirrors have no cowlings ■ AMIR-F20 Auxiliary front view mirror with a 200mm radius □ SUNV-H External smoke grey sunvisor □ AD-ROOF Roof air deflector □ AD-SIDEL Side air deflector extension panels □ AD-SIDES Short cab side air deflector for rigid bodywork □ AD-CHASX Chassis side skirts □ ADCF-F Additional black edging on chassis side skirt ■ HL-BASIC Halogen H7 head lamps □ HL-CLEAN Head lamp cleaner - washer jets □ HLP-ST Headlamp protection □ HL-ADJ Headlight adjustment - Switch in cab ■ UDRIVL Without auxiliary driving lights □ ASL-RF2 Two Hella H11 70W spotlamps in sign box - only available with the basic headlight and no lower driving lights. □ BEACOA2F Roof beacons - Two front roof mounted amber LED □ BEACOA2R Roof beacons - Two rear roof mounted amber LED □ BEACON-P Roof beacons - wiring preparation only □ BEACONA4 Roof beacons - Four amber LED - two front/ two rear □ CABPT-R1 Single outlet for roof mounted accessories ■ CABPT-R2 Twin outlets for roof mounted accessories. □ SPOTP-F Spotlamp preparation in front, max 280W □ SPOTP-R Spotlamp preparation on roof, max 280W □ SPOTP-RF Spotlamp preparation on cab roof and in cab front, max 2x280W □ ROS-IL2 Preparation kit for illuminated roof sign with switch loose in cab, fit after registration □ CSGN-FMX "Volvo FMX" headboard logo ■ HORN-F1S Horn - Air single tone - chassis mounted □ HORN-R2S Horn - Air - Two roof-mounted □ ANT-CBR Roof mounted antenna for CB radio, single aerial. Only Globetrotter cabs brings in extra DIN slots. □ ACCBR-AP Front, middle & rear roof mounted accessory brackets □ ACCBR-F Front roof mounted accessory bracket □ ACCBR-FM Front & middle roof mounted accessory brackets □ ACCBR-FR Front & rear roof mounted accessory brackets □ ACCBR-M Middle roof mounted accessory bracket □ ACCBR-R Rear roof mounted accessory bracket □ ACCBR-RM Rear & middle roof mounted accessory brackets □ RFCAR-BC Rear mudwing carrier, back of cab □ LADDER Ladder back of cab □ REFS-TW White cab conspicuity markings by packed in cab □ REFS-TY Yellow cab conspicuity markings by packed in cab 	<ul style="list-style-type: none"> □ 5WH220 Leg-height - 220mm □ 5WH230 Leg-height - 230 mm ■ 5WT-F014 Fifth wheel - Fontaine 150SP2 pressed steel □ 5WT-F015 Fifth wheel - Fontaine 3000 lightweight cast air operated slider - for moderate duty off-road. □ 5WT-JO10 Fifth wheel - Jost JSK 36 pressed □ 5WT-JO8 Fifth wheel - Jost JSK 37 cast □ 5WT-JO9 Fifth wheel - Jost JSK 42 cast □ 5WT-SH Fifth wheel - SAF-Holland/+GF+ SK-S 36.20 cast ■ 5WLM-B Maintenance - Basic fifth wheel - standard top plate □ 5WLM-L Maintenance - Low maintenance with nylon top plate □ 5WL-S1 Fifthwheel lubrication - locking mechanism and top plate □ 5WL-S2 Fifthwheel lubrication - locking mechanism □ TCIND Trailer connection indicator - Sensors for height, kingpin and coupling lock ■ RDECK Catwalk - Single plate and step □ RDECK-M Catwalk - Extended with two plates and step □ SRWL-PK Chassis-mounted working lamps - Side work and reverse lamp preparation and 3 position switch - Max load 280W □ SWL-2RA Chassis-mounted working lamps - Two amber rear-mounted LED lamps □ SWL-2RW Chassis-mounted working lamps - Two white rear-mounted LED lamps □ SWL-PK Chassis-mounted working lamps - Side work lamp preparation and 2 position switch - Max load 280W ■ WL-TA1W Coupling light - White □ WLC-H2A Two H3/70W working lamps with amber coloured lens high mounted back of cab □ WLC-H2W Two H3/70W white working lamps high mounted on the back of cab □ WLC-PKH Preparation kit, cables and switch for high mounted working lamps back of cab □ WLC-PKL Preparation kit, cables and switch for low mounted working lamps back of cab □ WLC-PKLH Preparation kit - cables and switch for low and high mounted working lamps back of cab. ■ ECBB-HIG Body builder electrical centre with body builder module □ BBCHAS1 One 7-pole connector for Body builder interface □ BBCHAS3 Three 7-pole connectors for Body builder interface □ BEPR-T2 Body builder electrical software preparation for tipper with remote control □ EXSTER External steering control - Volvo dynamic steering and bodybuilder module prepared for external control system, installed and computer by bodybuilder □ TD-BAS Trailer detection WITHOUT LED sensing ■ TD-LED Trailer detection with LED sensing □ AUXL-SPK Electrical preparation kit - wiring and switch for snow plough lights □ TAILPRE2 Tail lift preparation kit, wireless remote operation □ TAILPREP Taillift preparation kit - cab switch and warning in driver display □ AESW2 Two Body builder bistable electrical switches (marked AUX1 / AUX2) □ AESW2PK 2 Body builder bistable el.switches (marked AUX1/AUX2) and prep. for 4 more switches □ AUXSW-4 Wiring for 4 extra switches (from Body builder electrical centre to switch positions)
<h3>SUPERSTRUCTURE PREPARATIONS</h3>	
<ul style="list-style-type: none"> □ 5WM-ASM Mount - Air operated slider with 50mm L profiles ■ 5WM-ISOM Mount - 50mm L profiles with 10mm ISO plate - 60mm high above chassis frame □ 5WM-LPRO Mount - Direct to frame with inverted 'L'-profiles □ 5WM-MASM Mount - Manual slider with 50mm L profiles □ 5WH150 Leg-height - 150 mm □ 5WH175 Leg-height - 175mm □ 5WH185 Leg-height - 185 mm □ 5WH195 Leg-height - 195mm □ 5WH200 Leg-height - 200 mm □ 5WH205 Leg-height - 205 mm □ 5WH210 Leg-height - 210 mm 	<h3>DELIVERY SERVICES</h3> <ul style="list-style-type: none"> ■ TGW-4GWL Telematics gateway - GSM/GPRS/4G modem, LTE & WLAN □ FMS-PK Fleet Management System gateway □ DRUT2 Driver utility app - "My Truck" - two-year subscription For mobile phone, tablet, with android and IOS systems. Only available with Volvo Connect subscription

VOLVO

Volvo Truck Corporation
volvotrucks.com