

# MODEL RANGE

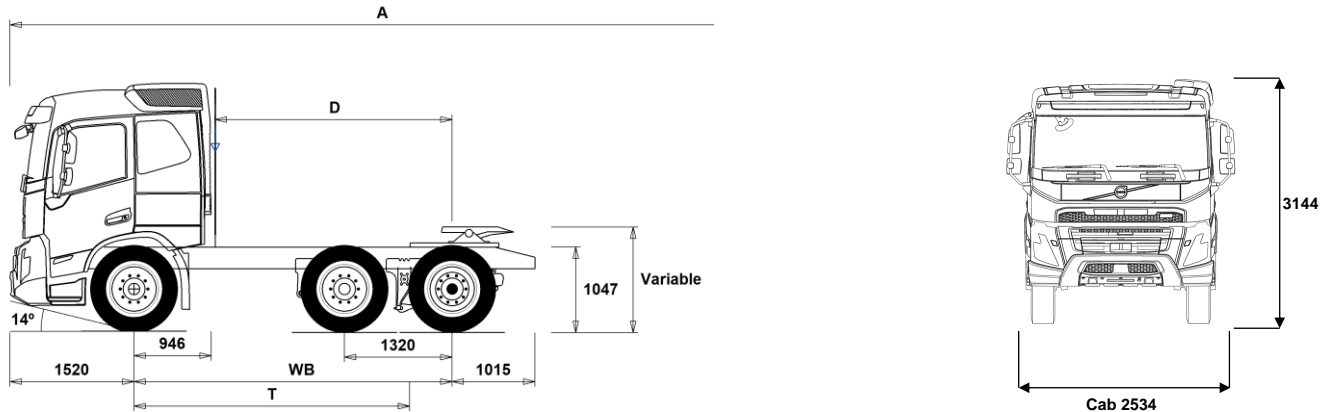

Volvo Trucks. Driving Progress

NEW FMX 13 6x2 Pusher Tractor - Standard or Lite - Rear Air Suspension FMX 62T P3A



## Chassis Dimensions [mm]

WB Wheelbase	3900	4100
A Overall Chassis Length	9106	9106
D Center of rear axle to back of cab	2904	3104
F Fifth Wheel Position (EC Directive 96/53)	925	925
T Theoretical Wheelbase	3379	3579

## Chassis Weights [kg]

Front Axle	4595	4605
Rear Bogie	3020	3025
Kerb Weight	7615	7630

## Turning Diameter [mm]

Turning Circle Diameter Kerb to Kerb	12400	13000
Turning Circle Diameter Wall to Wall	13900	14500

## Plated Weights [kg]

	Plated	Design
Gross Vehicle Weight	23400	26500
Gross Combination Weight	44000	44000
Front Axle	7500	7500
Rear Bogie	19000	19000

## Important Notes

### Chassis Dimensions

Cab Height: -16 mm for CAB-DAY, +312 mm for CAB-HSLP, -278 mm for CAB-LDAY, -278 mm for CAB-LSLP.

Front Axle to Back of Cab: -431 mm for CAB-DAY, -500 mm for CAB-LDAY, -6 mm for CAB-LSLP.

D-measure includes a front clearance of 50 mm and for rigid trucks also a subframe of 100 mm.

Height can vary  $\pm 20$  mm for leaf and  $\pm 10$  mm for air suspension.

All dimensions are for unladen chassis and any tag axles down. Chassis height used: CHH-HIGH.

Height change when chassis height CHH-MED,FRAME266: 0 mm.

Weight and dimensions are based upon the following tyres:

Front Axle Tyres:	315/80R22.5
Drive Axle Tyres:	315/80R22.5
Trailing/Tractor Axle Tyres:	315/80R22.5

**Chassis weight includes oil, water, AdBlue, 0 litres fuel and without driver. Kerb weight can vary  $\pm 3\%$ .**

Turning diameters are theoretically calculated. Tag axle used: PA-FIXED.

Legal weights can differ from country to country.

For more detailed weight information, including optional equipment weights, ask your Volvo sales contact to enter your specification into the Volvo Weight Information system (WIS).

Do NOT use this drawing for bodybuilding. Refer to Volvo Bodybuilder Instructions and chassis assembly drawing FMX62TP3A.

# MODEL RANGE

## NEW FMX 13 6x2 Pusher Tractor - Standard or Lite - Rear Air Suspension FMX 62T P3A

### CORE COMPONENTS

- CHH-HIGH** Chassis Height - High - for loading heights check the unique BEP chassis drawing
- CHH-MED** Chassis Height - Medium - for loading heights check the unique BEP chassis drawing
- PU-EHYS** Pusher axle - Electro-hydraulically steered
- PU-FIXS** Pusher axle - Fixed
- RAPD-GR** Rear air suspension, 2 axles - 1 pusher/1 driven
- FMX-DAY5** Cab - Day - with steel safety cage design  
Designed and built to Swedish impact and ECE R29 regulations
- FMX-HSL5** Cab - Globetrotter - with steel safety cage design  
Designed and built to Swedish impact and ECE R29 regulations
- FMX-LDA5** Cab - Low Day - with steel safety cage design  
Designed and built to Swedish impact and ECE R29 regulations
- FMX-LSL5** Cab - Low Sleeper - all-steel safety cage design.  
Built to Swedish impact and ECE R29 regulations
- FMX-SLP5** Cab - Sleeper - with steel safety cage design  
Designed and built to Swedish impact and ECE R29 regulations
- EU6SCR** Emission level - Euro VI step E
- D13 420S** Engine - D13K420 12.8 litre developing 420hp at 14-1800rpm.  
Peak torque 2100Nm at 860 -1400rpm.
- D13 460S** Engine - D13K460 12.8 litre developing 460hp at 14-1800rpm.  
Peak torque 2300Nm at 900-1400rpm.
- D13 500S** Engine - D13K500 12.8 litre developing 500hp at 14-1800rpm.  
Peak torque 2500Nm at 1000-1400rpm.
- D13 540S** Engine - D13K540 12.8 litre developing 540hp at 14-1800rpm.  
Peak torque 2600Nm at 1000-1450rpm.
- D13K420** D13K420 - 420hp engine
- D13K460** D13K460 - 460hp engine
- D13K500** D13K500 - 500hp engine
- D13K540** D13K540 - 540hp engine
- EBR-EPG** Engine Brake Type - Exhaust brake controlled by steering column switch
- EBR-EPGC** Engine Brake Type - Exhaust pressure governor for I shift gearbox
- EBR-VEB+** Engine Brake Type - Volvo engine brake + and exhaust pressure governor, enhanced performance from additional exhaust rocker control. Retardation 375kW
- AT2612F** Gearbox - AT2612F 12-speed "I-shift" automated mechanical suitable for gross train weights up to 60tonne only.  
Refer to sales engineering when used in conjunction with a PTO
- ATO2612F** Gearbox - ATO2612F 12-speed "I-shift" overdrive automated mechanical, suitable for gross train weights up to 60tonne.  
Refer to sales engineering when used in conjunction with a PTO
- PT2606** Gearbox - Powertronic automatic 6-speed, max. engine torque 2600 Nm, max. permitted GCW 130000 kg
- SPO2812** Gearbox - SPO2812 - 12-speed I-shift Dual Clutch automated mechanical GCW 60tonne
- ASO-C** Crawler gear -  
Ratio direct top gearbox 19:1  
Ratio Overdrive gearbox 17:1
- ASO-ULC** Ultra low crawler and crawler gear -  
Ratios direct top gearbox 32:1 and 19:1  
Ratios Overdrive box 32:1 and 17:1
- RSH1370F** Drive Axle - RSH1370F 13-tonne hub reduction with differential lock - design GCW 70 tonne
- RSS1344E** Drive Axle - RSS1344E single reduction with differential lock - design GCW 44 tonne
- RSS1352A** Drive Axle - RSS1352A single reduction 13 tonne with differential lock - design GCW 52 tonne
- RSS1370A** Drive Axle - RSS1370A single reduction 13 tonne with differential lock - design GCW 70 tonne
- RSS1370B** Drive Axle - RSS1370B single reduction 13 tonne with differential lock - design GCW 70 tonne

Standard Equipment

Optional Equipment

For more detailed information about cab and powertrain equipment, please refer to separate specification sheets.

For all possible options and combinations of options please consult your Volvo sales contact who can create a specification to match your requirements using the Volvo Sales Support system (VSS).

The factory reserves the right to modify design and change equipment without previous notification. The specification can vary from country to country.

### PACKAGES

- FUELPACK** Long Haul Fuel Economy driving package
- DRIVE5** Drive Package
- DRIVE5+** Drive+ Package
- DRIVE5++** Drive++ Package
- 1LIVINFM** Sleep & Resting Package - Living one-bed
- 2LIVINFM** Sleep & Resting Package - Living two-bed
- INFOBAS** Basic media package without secondary display
- INFODF** Media Information Platform with Dynafleet Support
- INFOMED** Media Information Platform - Medium level
- INFONAV** Media Information Platform with Navigation
- INFONDF** Media Information Platform with Navigation & Dynafleet Support
- VISIX5** Visibility Package
- SAFE-VE** Active Safety Package
- SAFE-VE+** Active Safety+ Package
- CHASSIS**
- FST-AIR** Front suspension type - Air
- FST-PAR** Front suspension type - 2 leaf parabolic springs
- FSL5-BAS** Front suspension levelling - basic stroke
- FSL5-HI** Front suspension levelling - high stroke for demount operations - check with bodybuilder
- FAL7.5** Front axle design capacity - 7.5 tonne
- FAL8.0** Front axle design capacity - 8.0 tonne - check tyre capacity
- FAL8.5** Front axle design capacity - 8.5 tonnes
- FAL9.0** Front axle design capacity - 9.0 tonne - check tyre capacity
- FSTAB** Front anti-roll bar - Normal stiffness
- FSTAB2** Front anti-roll bar - Medium stiffness
- FSTAB3** Front anti-roll bar - High stiffness
- RAL19** Rear bogie design capacity - 19 tonne
- RSTAB1** Rear anti-roll bar - Normal stiffness
- RSTAB3** Rear anti-roll bar - Stiff
- RALIM115** Rear-axle load limiter -11.5 tonne - speed controlled
- ASF-DL1** Air suspension with 1 driving level
- ASF-DL3** Air suspension with 3 driving levels
- ACTST-TO** Active Steering- Volvo Dynamic Steering - VDS - with extra electronic pump and torque overlay
- ASFE-BAS** Active steering feature - Basic - Volvo Dynamic Steering - VDS - only
- ASFE-OG** Active steering feature - Volvo Dynamic Steering - VDS - with stability assist - oversteer
- ASFE-PO** Active steering feature - Volvo Dynamic Steering - VDS - with personal settings and stability assist
- ASFE-PS** Active steering feature - Volvo Dynamic Steering - VDS - with personal settings
- PSS-SING** Power steering system - Single
- PSP-FIX** Power steering pump - Fixed displacement
- PSP-VAR** Power steering pump - Variable displacement
- EBS-MED** Brake package - EBS medium including "hill" hold function
- SUSPL-EC** Remote electronic control on wander-lead for air suspension levelling
- FRAME266** Chassis frame section external height - 266 mm
- FRAME300** Chassis frame section external height - 300 mm
- FST6565** Chassis frame thickness - 6.5 mm web and flange
- FST7070** Chassis frame thickness - 7 mm web and flange
- FST8080** Chassis frame thickness - 8 mm web and flange
- FIL-EEEB** Chassis frame inner liner - From the end of the engine to the end of the bogie
- FIL-TXEB** Chassis frame inner liner - From gearbox member to the end of the bogie

# MODEL RANGE

## NEW FMX 13 6x2 Pusher Tractor - Standard or Lite - Rear Air Suspension FMX 62T P3A

- **BBOX-EF** Battery box position - End of the frame in rear overhang
  - **BBOX-L** Battery box position - Left hand side
  - **BATS-D** Dual energy battery system - 2 living batteries and 2 starter batteries.
  - **BATS-S** Single energy battery system (2 batteries)
  - **2BAT210B** Battery Capacity - 2 x 210 Ah - Gel type
  - **2BAT210C** Battery Capacity - 2 x 210 Ah - AGM Absorbent Glass-fibre Material type
  - **BATTAMP** Battery management - Voltage and current gauge
  - **BATTIND** Battery management - Charge indicator
  - **ADR2** ADR Adaptation - For transportation of dangerous goods on the road - Note does NOT include safe loading pass package if required this is quoted separately
  - **MSWI-A** Battery master switch - ADR switch circuit shut down
  - **MSWI-C** Battery master switch - Chassis mounted toggle by the battery box
  - **MSWI-R** Battery master switch - Key fob operated remote controlled
  - **UR-FUEL** Without right-hand fuel tank  
Min volume 150l  
Max volume 550l
  - **L480A71S** Left fuel tank - 480litre aluminium diameter 710mm with catwalk & steps  
Min volume 160l  
Max volume 550l
  - **ADTP-BC** AdBlue tank position - Behind and under the cab on the right-hand side
  - **ADTP-R** AdBlue tank position - Chassis mounted on the right-hand side
  - **ADB048** Plastic AdBlue tank - 48 litre
  - **ADB050** Plastic AdBlue tank - 50 litre under/behind the cab
  - **ADB064** Plastic AdBlue tank - 64 litre
  - **ADB068** Plastic AdBlue tank - 68 litre
  - **ADB090** Plastic AdBlue tank - 90 litre
  - **ADB100** Plastic AdBlue tank - 100 litre
  - **ADTC-BF** AdBlue tank cover with satin alloy look decorative cover
  - **FCAP-L** Diesel and AdBlue filler cap - Locking
  - **FUFF-AS** Fuel filler - Anti-spill device
  - **FUFF-ATS** Fuel filler - Anti-spill & anti-syphon device
  - **ESH-REAR** Exhaust - Horizontal silencer - rear outlet
  - **ESH-RIGH** Exhaust - Horizontal silencer - right outlet
  - **ESH-VERT** Exhaust - Horizontal silencer - vertical outlet
  - **EXST-SSP** Stainless steel exhaust stack - NOT polished
  - **EXST-ST** Steel exhaust stack
  - **WHC-FOL2** Two foldable wheel chocks
  - **WHCP-F** Wheel chock carrier position - In the front part of the vehicle
  - **WHCP-T** Wheel chock carrier position - Outer luggage locker
  - **SUP-BAS** EC approved chassis side guards
  - **CHAIN-S** Snow chains
  - **HOOK-SC** Snow chain hooks
  - **TOWF-HD1** Front towing device - One heavy-duty front towing device
  - **RFEC-B** Rear frame profile - Tapered
  - **TOWR-ONE** Towing hitch attached to rear crossmember
  - **TREL15** Trailer electrical connection - Single 15 pin - ADR certified
  - **TREL7** 7 pole - 24N trailer electrical suzie
  - **TREL7-7** Trailer electrical connection - 2 x 7 pin - 24N and 24S
  - **TBC-DUO** Duomatic type air line connectors
  - **TBC-EC** Trailer brakes with EC palm coupling connectors
  - **TBC-GBR** 'C' and 'CA' type air line connectors
  - **TRBR-HCF** Full pressure hand controlled trailer brake
  - **TRBR-STA** Stationary trailer brake control
  - **TRB-STRE** Stretch Brake - Automatic low speed trailer brake activation to avoid jack-knifing and improve steerability
  - **RFEND-B** Three piece EC approved rear mud wings and spray flaps
  - **RFH-BAS** Basic rear wing height
  - **RFH-HIG** High rear wing height - higher wing tops
  - **RFH-LOW** Lower rear wing height - shallower wing tops
  - **ATANK-AL** Air tanks - Aluminium
  - **ATANK-ST** Air tanks - Steel
  - **TL-LED** Rear lights - LED
  - **BLIGHT-E** Emergency brake light
- ### WHEELS & TYRES
- **RT-AL** Wheels - Alcoa brushed aluminium rims - standard holes for long stud fixing
  - **RT-ALDP** Wheels - Alcoa Dura-Bright aluminium rims - standard holes for long stud fixing
  - **RT-ALDPD** Wheels - Alcoa Dura-Bright EVO aluminium rims - countersunk holes for short stud fixing
  - **RT-ALDU** Wheels - Alcoa brushed aluminium rims - countersunk holes for short stud fixing
  - Wheels - Steel rims
  - **RT-STEEL** Wheels - Steel rims
  - **WCAP** Aerodynamic hub caps
  - **JACK-12T** 12 tonne bottle jack
  - **JACK-15T** 15 tonne bottle jack
  - **JACK-20T** 20 tonne bottle jack
  - **TOOL-BAS** Basic Toolkit
  - **TOOLKIT** Complete tool kit
  - **INFLAHOS** Tyre inflation hose
  - **GAUGE-TP** Tyre pressure gauge
- ### DRIVELINE EQUIPMENT
- **TRAP-HD** Reinforced gearbox application
  - **DRM-BE** Balanced & Economy Drive Mode
  - **DRM-E** Economy Drive Mode
  - **PVT-MAP** I-See Predictive Cruise Control - using map based topography information
  - **CRUIS-E** Eco cruise control (with eco-roll and I-cruise, controls in steering wheel)
  - **CRUIS-E4** Eco fleet software - with cruise speed 85, I-See and push button I-shift.
  - **CRUIS-E5** Eco torque software - Improved economy mode. Fuel economy optimized cruise control for I-Save
  - Cruise control, standard
  - **CRUISEC** Cruise control, standard
  - **AMSO-AUT** Enhanced I-shift software with manual shift available in auto mode and kickdown facility on accelerator pedal
  - **AVO-ENH** I-Shift application software - for construction and off road applications
  - **APF-ENH** I-shift enhanced PTO functions
  - **RET-TH** Gearbox mounted retarder
  - **RET-TPT** Hydraulic Retarder for Powertronic gearbox
  - **TC-HWO** Transmission oil cooler - water to oil
  - **TC-MAOH2** Extra high performance transmission oil cooler - air to oil with front mounted radiator
  - **TC-MWO** Basic transmission oil cooler - water to oil
  - **2COM1100** Air compressor - Two-cylinder 1100 litres per minute
  - **2COMP900** Air compressor - Two-cylinder 900 litres per minute
  - **CLU-AIRC** Clutchable air compressor
  - **AIRIN-HI** Air intake - Roof-mounted behind cab on the left-hand side
  - **AIRIN-LO** Low level air intake behind cab on left hand side
  - **ACL1ST-S** Air filter - two-stage element
  - **24AL110B** Alternator capacity - 110 amp
  - **24AL120B** Alternator capacity - 120 amp alternator

■ Standard Equipment

□ Optional Equipment

For more detailed information about cab and powertrain equipment, please refer to separate specification sheets.

For all possible options and combinations of options please consult your Volvo sales contact who can create a specification to match your requirements using the Volvo Sales Support system (VSS).

The factory reserves the right to modify design and change equipment without previous notification. The specification can vary from country to country.

# MODEL RANGE

## NEW FMX 13 6x2 Pusher Tractor - Standard or Lite - Rear Air Suspension FMX 62T P3A

<input type="checkbox"/> <b>24AL150B</b>	Alternator capacity - 150 amp	<input checked="" type="checkbox"/> <b>AIRBAG</b>	SRS Driver's air bag
<input type="checkbox"/> <b>CCV-C</b>	Closed crankcase engine ventilation	<input type="checkbox"/> <b>INST-BAS</b>	Basic level instruments
<input checked="" type="checkbox"/> <b>CCV-OX</b>	Closed crankcase ventilation for cold markets	<input checked="" type="checkbox"/> <b>DRC-AMII</b>	DPF Regeneration control switch - for manual and switching off regeneration
<input checked="" type="checkbox"/> <b>PRIM-EL</b>	Electrical priming pump	<input checked="" type="checkbox"/> <b>1DAYDIG2</b>	Tachograph - Continental VDO 4.0
<input type="checkbox"/> <b>PRIM-MAN</b>	Manual priming pump	<input type="checkbox"/> <b>ARSL</b>	Additional road speed limit - switch in dashboard
<input type="checkbox"/> <b>AF-R</b>	Hot fuel recirculation heated fuel filter	<input checked="" type="checkbox"/> <b>ESP-BAS1</b>	Electronic Stability Control
<input checked="" type="checkbox"/> <b>FUEFE2LW</b>	Large engine mounted dual fuel filter with water separator	<input type="checkbox"/> <b>ESPC-RO</b>	ESP (Electronic Stability Program) functionality control - Reduced / Off
<input type="checkbox"/> <b>FUEFE2SW</b>	Small engine mounted dual fuel filter with water separator	<input type="checkbox"/> <b>HWSS-ACB</b>	Adaptive cruise control ACC with forward collision warning and AEBS advanced emergency brake system
<input type="checkbox"/> <b>EST-AID</b>	Engine starting aid -Preheating element in the air inlet manifold	<input checked="" type="checkbox"/> <b>HWSS-FCB</b>	Forward collision warning with AEBS advanced emergency brake system
<input type="checkbox"/> <b>220EBH15</b>	220V/1.5Kw electric engine block heater	<input checked="" type="checkbox"/> <b>LSS-DW</b>	Lane departure-warning system
<input type="checkbox"/> <b>PTER-100</b>	Engine power-take-off - Rear-mounted with DIN100/ISO7646 flange	<input type="checkbox"/> <b>LCS</b>	Lane change support
<input type="checkbox"/> <b>PTER-DIN</b>	Engine power-take-off - Rear-mounted with DIN5462 (female) splined shaft for a close-coupled pump Models with 3 steering axles will use this to drive the steering pump (AUXPSP)	<input type="checkbox"/> <b>DAS-W</b>	Driver Alert Support system
<input type="checkbox"/> <b>PTER1400</b>	Engine power-take-off - Rear-mounted with SAE 1410 flange	<input type="checkbox"/> <b>RSENS-W</b>	Rain sensing windscreen wipers
<input type="checkbox"/> <b>HPE-F101</b>	Parker F1-101, engine mounted, fixed displacement, single flow, engine mounted hydraulic pump	<input type="checkbox"/> <b>CU-ECC</b>	Cab Climate Unit - Electrically controlled air conditioning with sun sensor
<input type="checkbox"/> <b>HPE-F41</b>	Parker F1-41, engine mounted, fixed displacement, single flow, engine mounted hydraulic pump	<input type="checkbox"/> <b>CU-ECC2</b>	Cab Climate Unit - Electrically controlled air conditioning with a carbon filter, sun, mist, and air quality sensor
<input type="checkbox"/> <b>HPE-F51</b>	Parker F1-51, engine mounted, fixed displacement, single flow, engine mounted hydraulic pump	<input checked="" type="checkbox"/> <b>CU-MCC</b>	Cab Climate Unit - Manual air conditioning
<input type="checkbox"/> <b>HPE-F61</b>	Parker F1-61, engine mounted, fixed displacement, single flow, engine mounted hydraulic pump	<input checked="" type="checkbox"/> <b>IMMOBIL</b>	Thatcham H2 approved immobiliser
<input type="checkbox"/> <b>HPE-F81</b>	Parker F1-81, engine mounted, fixed displacement, single flow, engine mounted hydraulic pump	<input type="checkbox"/> <b>ALARM-E</b>	Enhanced vehicle alarm - Thatcham H1 approved - Cab plus external sensor for body/trailer
<input type="checkbox"/> <b>HPE-T53</b>	Parker F2-53/53, engine mounted, Fixed displacement, Twin flow engine mounted hydraulic pump	<input type="checkbox"/> <b>ALCOLOCK</b>	Alcolock
<input type="checkbox"/> <b>HPE-T70</b>	Parker F2-70/35, engine mounted, Fixed displacement, Twin flow engine mounted hydraulic pump	<input type="checkbox"/> <b>BUPMON</b>	Back up monitor - Digital reverse camera, parameter & lead supplied loose in cab.
<input type="checkbox"/> <b>HPE-V45</b>	Parker VP1-45, variable displacement, single flow, engine mounted hydraulic pump	<input type="checkbox"/> <b>PHONE-PK</b>	Telephone preparation kit (antenna, antenna attachm. cable incl.)
<input type="checkbox"/> <b>HPE-V75</b>	Parker VP1-75, variable displacement, single flow, engine mounted hydraulic pump	<input type="checkbox"/> <b>ISUNS-BS</b>	Side sun visor - Driver & passenger side
<input type="checkbox"/> <b>PTPT-D</b>	Powertronic PTO, 1 front/upper DIN connection for plug-in pump (max. 850 Nm)	<input checked="" type="checkbox"/> <b>ISUNS-DS</b>	Side sun visor - Driver-side
<input type="checkbox"/> <b>PTPT-F</b>	Powertronic PTO, 1 front/upper rear facing SAE flange conn. for prop shaft (max.850 Nm)	<input type="checkbox"/> <b>ISUNF-B</b>	Interior front sun visor without mirror
<input type="checkbox"/> <b>PTR-D</b>	Gearbox PTO for plug-in pump, 0.71xeng speed	<input type="checkbox"/> <b>ISUNF-MD</b>	Interior front sun visor with mirror on driver side
<input type="checkbox"/> <b>PTR-DH</b>	Gearbox driven high speed PTO for one plug-in hydraulic pump	<input type="checkbox"/> <b>ISUNF-RE</b>	Electrically operated textile interior sun blind
<input type="checkbox"/> <b>PTR-DM</b>	Gearbox driven medium speed PTO for one plug-in hydraulic pump	<input checked="" type="checkbox"/> <b>ISUNF-RM</b>	Manually operated textile interior sun blind
<input type="checkbox"/> <b>PTR-F</b>	Gearbox driven PTO with rear flange connection	<input type="checkbox"/> <b>ADFS</b>	Two extra DIN slots in front shelf - can be fitted with card or drawer available as an accessory
<input type="checkbox"/> <b>PTR-FH</b>	Gearbox driven high speed PTO with SAE drive flange	<input checked="" type="checkbox"/> <b>BUPALARM</b>	Reverse alarm
<input type="checkbox"/> <b>PTR-FL</b>	Gearbox driven low speed PTO with SAE drive flange	<input type="checkbox"/> <b>RTOLL-PK</b>	Road toll PREPARATION kit for trucks operating with "Toll Collect" in Germany
<input type="checkbox"/> <b>PTRD-D</b>	Gearbox driven HIGH SPEED PTO for two plug-in hydraulic pumps	<input type="checkbox"/> <b>LOADIND</b>	Load indicator with central dashboard display
<input type="checkbox"/> <b>PTRD-D1</b>	PTRD-D1 Gearbox driven HIGH SPEED PTO (1 SAE flange & 1 plug-in hydraulic pump)	<input type="checkbox"/> <b>REMC-MF</b>	Multi-functio wireless remote control
<input type="checkbox"/> <b>PTRD-D2</b>	Gearbox driven HIGH SPEED PTO (2 SAE flanges & 1 plug-in hyd pump)	<input type="checkbox"/> <b>FIREXT3S</b>	Fire extinguisher - 3kg mounted on the seat base
<input type="checkbox"/> <b>PTRD-F</b>	PTO with 1 DIN + 1 flange connection rear, manual gearbox	<input type="checkbox"/> <b>WARNVEST</b>	High visibility warning vest - no sleeves
<input type="checkbox"/> <b>HPG-F101</b>	Parker F1-101 gearbox mounted, fixed displacement, single flow, hydraulic pump	<input type="checkbox"/> <b>AIDKIT</b>	First aid kit - Legal demand for EU markets including delivery to EU bodybuilder
<input type="checkbox"/> <b>HPG-F41</b>	Parker F1-41 gearbox mounted, fixed displacement, single flow, hydraulic pump	<input type="checkbox"/> <b>AIDKIT1B</b>	First aid kit - Legal demand for trucks transiting Germany
<input type="checkbox"/> <b>HPG-F51</b>	Parker F1-51 gearbox mounted, fixed displacement, single flow, hydraulic pump	<input type="checkbox"/> <b>WARNLAMP</b>	Portable warning lamp
<input type="checkbox"/> <b>HPG-F61</b>	Parker F1-61 gearbox mounted, fixed displacement, single flow, hydraulic pump	<input type="checkbox"/> <b>LAMP-IN</b>	Inspection lamp
<input type="checkbox"/> <b>HPG-F81</b>	Parker F1-81 gearbox mounted, fixed displacement, single flow, hydraulic pump	<input type="checkbox"/> <b>BULBKIT</b>	Bulb and fuse kit
<input checked="" type="checkbox"/> <b>STWPOS-R</b>	Steering wheel position - RIGHT-HAND DRIVE	<input type="checkbox"/> <b>WRITEPAD</b>	Writing pad
<input type="checkbox"/> <b>STWM-LE</b>	Leather steering wheel	<input checked="" type="checkbox"/> <b>DST-CF4</b>	Driver seat - Suspended, adjustable shock absorber, travel, backrest & lumbar controls - seatbelt mounted to the seat
<input type="checkbox"/> <b>STGW-AD2</b>	Adjustable steering wheel with neck tilt		
<input checked="" type="checkbox"/> <b>STGW-ADJ</b>	Adjustable steering wheel		

Standard Equipment

Optional Equipment

For more detailed information about cab and powertrain equipment, please refer to separate specification sheets.

For all possible options and combinations of options please consult your Volvo sales contact who can create a specification to match your requirements using the Volvo Sales Support system (VSS).

The factory reserves the right to modify design and change equipment without previous notification. The specification can vary from country to country.

# MODEL RANGE

## NEW FMX 13 6x2 Pusher Tractor - Standard or Lite - Rear Air Suspension FMX 62T P3A

- DST-CF5** Driver seat - Suspended with adjustable shock absorber, travel, backrest, lumbar & heat controls - seatbelt mounted to the seat
- DST-CF6** Driver seat - Suspended with adjustable shock absorber, travel, backrest, lumbar, heat and ventilation controls - seatbelt mounted to the seat
- SBD-RED** Seat belt colour - Red
- SBPRE-DS** Driver seat belt pretensioner
- **PST-BAS1** Passenger seat - Fixed non suspended fold up with seatbelt mounted in cab
- PST-CF4** Passenger seat - Suspended, adjustable shock absorber, travel, backrest & lumbar controls - seatbelt mounted to the seat
- PST-CF5** Passenger seat - Suspended with adjustable shock absorber, travel, backrest, lumbar & heat controls - seatbelt mounted to the seat
- PST-STD2** Passenger seat - Fixed with backrest adjustment, non suspended with seatbelt mounted in cab
- PST-STD4** Passenger seat - Standard suspended with seatbelt mounted in cab
- SBPRE-PS** Passenger seat belt pretensioner
- ARMRE-BB** Armrests - Two on both driver & passenger seats
- ARMRE-DB** Armrests - Two on the driver seat
- ARMRE-PB** Armrests - Two on the passenger seat
- ARU-BAS** Armrest upholstery - Vinyl
- ARU-LEA** Armrest upholstery - Leather
- **FMAT-RUB** Footwell floor mats - Rubber
- FMAT-TX2** Footwell floor mats - Two sets, Rubber and textile with an embossed pile supplied in the cab
- **LBK70** Lower bunk 700 x2000 mm, fixed
- MATL-FI** Firm lower bunk pocket sprung mattress
- **MATL-SF** Lower flexizone mattress - semi-firm, pocket springs up to 100kg - 16 stone
- OLMAT-BA** 35mm mattress overlay protector
- OLMAT-PR** 50mm premium mattress overlay protector
- TBK60F** Fixed foldable top bunk 600 x 1900mm
- TBK70F** Fixed foldable top bunk 700 x 1900mm
- PH-CAB2** 1.8kW Air to air night heater
- PH-ENGCA** Engine and cab night heater
- PH-SS** Short stop heater
- SLCP-BAS** Sleeper control panel - Basic with switches for interior light, night heater, roof hatch and door lock
- ETSB-F** Storage on engine tunnel - Central document box with two rear cup holders
- ETSB-FR** Storage on engine tunnel - Central document box with two rear cup holders & open storage pocket on cab rear wall
- ETSB-R** Storage on engine tunnel - Open storage pocket on cab rear wall
- RUS-BAS** Rear cab upper storage - 300 mm high
- RUS-HIG** Rear cab upper storage - 440 mm high - volume 245 litres
- REF-ICPK** Fridge: engine tunnel mounted preparation kit
- REFR-RUS** Fridge - 28 litre rear upper wall mounted with dividers
- MICRO-PK** Wiring preparation kit for microwave oven
- BOTH-D** One bottle holder under dashboard centre section
- COFMA-PK** Coffee maker, preparation kit.
- **INLI-BAS** Interior white LED lights - basic
- INLI-NL** Interior white and red night LED light with no dimmer
- INLI-NLD** Interior white and red night LED light with dimmer
- ARL-FLEX** Two flexible reading lamps (snake lamps)
- **RH-EE** Fixed tinted glass sky window with emergency exit
- RH-ER** Steel roof hatch - Electrically operated, rear opening with emergency exit
- RH-ETR** Tinted glass roof hatch - Electrically operated, rear opening with emergency exit
- RH-MTR** Tinted glass roof hatch - Manually operated, rear opening with emergency exit
- **GLAS-TIN** Tinted windows.
- SWIND-BS** Extra side window on both sides behind "B" pillar
- SWIND-PS** Cab side window - Left side rear behind 'B' post
- AWIND-RF** Rear window
- VANMIR** Vanity mirror in front shelf
- AS-FUS** Extra shelf in front upper storage compartments
- INFOT-PK** Preparation kit for the mounting of a flat screen TV in cab above the driver's door, includes bracket, electrical and speaker connections

### CAB EXTERIOR

- **EXTL-BAS** Basic exterior finish - Satin Volvo badges, grey grille, instep, bumper, bumper spoiler, grille, door handles mirror housing and sunvisor if specified.
- **DGLAS-H** Tempered door glass
- DGLAS-L** Laminated door glass
- **LOCK-CTL** Door locks - Central locking with key
- LOCK-REM** Door locks - Remote central locking
- **BUMP-HD** Heavy duty front bumper
- GUARD-EH** Engine guard to protect sump and engine hoses
- **BUGNET** Insect screen in front of radiator
- CTILT-P-E** Electrically operated hydraulic cab tilt
- **CTILT-P-M** Manually operated hydraulic cab tilt
- FCABS-A** Front cab suspension - Air
- **FCABS-M** Front cab suspension - Mechanical spring
- RCABS-A** Rear cab suspension - Air
- **RCABS-M** Rear cab suspension - Mechanical spring
- MIRCFCPX** Mirrors - Electrically heated and operated - FMX- main and wide-angle with manually adjusted kerb view mirror on the passenger side and position camera in nearside mirror arm. To increase direct vision to the side the main mirrors have no cowlings
- MIRCOMFX** Electrically heated and operated -FMX- main and wide-angle mirrors with manually adjusted passenger kerb mirror, to increase direct vision to the side the main mirrors have no cowlings
- **MIRSTDX2** Electrically heated -FMX- main and wide-angle mirrors with manually adjusted passenger kerb mirror, to increase direct vision to the side the main mirrors have no cowlings
- **AMIR-F20** Auxiliary front view mirror with a 200mm radius
- SUNV-H** External smoke grey sunvisor
- AD-ROOF** Roof air deflector
- AD-SIDEL** Side air deflector extension panels
- AD-SIDES** Short cab side air deflector for rigid bodywork
- AD-CHASX** Chassis side skirts
- ADCF-F** Additional black edging on chassis side skirt
- **HL-BASIC** Halogen H7 head lamps
- HL-CLEAN** Head lamp cleaner - washer jets
- HLP-ST** Headlamp protection
- HL-ADJ** Headlight adjustment - Switch in cab
- ASL-RF2** Two Hella H11 70W spotlamps in sign box - only available with the basic headlight and no lower driving lights.
- BEACOA2F** Roof beacons - Two front roof mounted amber LED
- BEACOA2R** Roof beacons - Two rear roof mounted amber LED
- BEACON-P** Roof beacons - wiring preparation only

■ Standard Equipment

Optional Equipment

For more detailed information about cab and powertrain equipment, please refer to separate specification sheets.

For all possible options and combinations of options please consult your Volvo sales contact who can create a specification to match your requirements using the Volvo Sales Support system (VSS).

The factory reserves the right to modify design and change equipment without previous notification. The specification can vary from country to country.

# MODEL RANGE

## NEW FMX 13 6x2 Pusher Tractor - Standard or Lite - Rear Air Suspension FMX 62T P3A

- **BEACONA4** Roof beacons - Four amber LED - two front/ two rear
  - **CABPT-R1** Single outlet for roof mounted accessories
  - **CABPT-R2** Twin outlets for roof mounted accessories.
  - **SPOTP-F** Spotlamp preparation in front, max 280W
  - **SPOTP-R** Spotlamp preparation on roof, max 280W
  - **SPOTP-RF** Spotlamp preparation on cab roof and in cab front, max 2x280W
  - **ROS-IL2** Preparation kit for illuminated roof sign with switch loose in cab, fit after registration
  - **CSGN-FMX** "Volvo FMX" headboard logo
  - **HORN-F1S** Horn - Air single tone - chassis mounted
  - **HORN-R2S** Horn - Air - Two roof-mounted
  - **ANT-CBR** Roof mounted antenna for CB radio, single aerial. Only Globetrotter cabs brings in extra DIN slots.
  - **ACCB-R-AP** Front, middle & rear roof mounted accessory brackets
  - **ACCB-R-F** Front roof mounted accessory bracket
  - **ACCB-R-FM** Front & middle roof mounted accessory brackets
  - **ACCB-R-FR** Front & rear roof mounted accessory brackets
  - **ACCB-R-M** Middle roof mounted accessory bracket
  - **ACCB-R-R** Rear roof mounted accessory bracket
  - **ACCB-R-RM** Rear & middle roof mounted accessory brackets
  - **RFCAR-BC** Rear mudwing carrier, back of cab
  - **LADDER** Ladder back of cab
  - **REFS-TW** White cab conspicuity markings by packed in cab
  - **REFS-TY** Yellow cab conspicuity markings by packed in cab
- ### SUPERSTRUCTURE PREPARATIONS
- **5WM-ASL** Mount - Air operated slider with 4mm L profiles
  - **5WM-ASM** Mount - Air operated slider with 50mm L profiles
  - **5WM-ISOL** Mount - Flush L profiles with 12mm ISO plate - 16mm high above chassis frame
  - **5WM-ISOM** Mount - 50mm L profiles with 10mm ISO plate - 60mm high above chassis frame
  - **5WM-LPRO** Mount - Direct to frame with inverted 'L'-profiles
  - **5WM-MASM** Mount - Manual slider with 50mm L profiles
  - **5WH150** Leg-height - 150 mm
  - **5WH160** Leg-height - 160 mm
  - **5WH175** Leg-height - 175mm
  - **5WH185** Leg-height - 185 mm
  - **5WH195** Leg-height - 195mm
  - **5WH200** Leg-height - 200 mm
  - **5WH205** Leg-height - 205 mm
  - **5WH210** Leg-height - 210 mm
  - **5WH220** Leg-height - 220mm
  - **5WH230** Leg-height - 230 mm
  - **5WT-FO14** Fifth wheel - Fontaine 150SP2 pressed steel
  - **5WT-FO15** Fifth wheel - Fontaine 3000 lightweight cast air operated slider - for moderate duty off-road.
  - **5WT-JO10** Fifth wheel - Jost JSK 36 pressed
  - **5WT-JO8** Fifth wheel - Jost JSK 37 cast
  - **5WT-JO9** Fifth wheel - Jost JSK 42 cast
  - **5WT-SH** Fifth wheel - SAF-Holland/+GF+ SK-S 36.20 cast
  - **5WLM-B** Maintenance - Basic fifth wheel - standard top plate
  - **5WLM-L** Maintenance - Low maintenance with nylon top plate
  - **5WL-S1** Fifthwheel lubrication - locking mechanism and top plate
  - **5WL-S2** Fifthwheel lubrication - locking mechanism
  - **TCIND** Trailer connection indicator - Sensors for height, kingpin and coupling lock
  - **RDECK** Catwalk - Single plate and step
  - **RDECK-M** Catwalk - Extended with two plates and step
  - **SRWL-PK** Chassis-mounted working lamps - Side work and reverse lamp preparation and 3 position switch - Max load 280W
  - **SWL-2RA** Chassis-mounted working lamps - Two ambe rear-mounted LED lamps
  - **SWL-2RW** Chassis-mounted working lamps - Two white rear-mounted LED lamps
  - **SWL-PK** Chassis-mounted working lamps - Side work lamp preparation and 2 position switch - Max load 280W
  - **WL-TA1W** Coupling light - White
  - **WLC-H2A** Two H3/70W working lamps with amber coloured lens high mounted back of cab
  - **WLC-H2W** Two H3/70W white working lamps high mounted on the back of cab
  - **WLC-PKH** Preparation kit, cables and switch for high mounted working lamps back of cab
  - **WLC-PKL** Preparation kit, cables and switch for low mounted working lamps back of cab
  - **WLC-PKLH** Preparation kit - cables and switch for low and high mounted working lamps back of cab.
  - **ECBB-HIG** Body builder electrical centre with body builder module
  - **BBCHAS1** One 7-pole connector for Body builder interface
  - **BBCHAS3** Three 7-pole connectors for Body builder interface
  - **BEPR-T2** Body builder electrical software preparation for tipper with remote control
  - **EXSTER** External steering control - Volvo dynamic steering and bodybuilder module prepared for external control system, installed and computer by bodybuilder
  - **TD-BAS** Trailer detection WITHOUT LED sensing
  - **TD-LED** Trailer detection with LED sensing
  - **AUXL-SPK** Electrical preparation kit - wiring and switch for snow plough lights
  - **TAILPRE2** Tail lift preparation kit, wireless remote operation
  - **TAILPREP** Taillift preparation kit - cab switch and warning in driver display
  - **AESW2** Two Body builder bistable electrical switches (marked AUX1 / AUX2)
  - **AESW2PK** 2 Body builder bistable el.switches (marked AUX1/AUX2) and prep. for 4 more switches
  - **AUXSW-4** Wiring for 4 extra switches (from Body builder electrical centre to switch positions)
- ### DELIVERY SERVICES
- **TGW-4GWL** Telematics gateway - GSM/GPRS/4G modem, LTE & WLAN
  - **FMS-PK** Fleet Management System gateway
  - **DRUT2** Driver utility app - "My Truck" - two-year subscription For mobile phone, tablet, with android and IOS systems. Only available with Volvo Connect subscription



Volvo Truck Corporation  
volvotrucks.com