

MODEL RANGE

NEW FMX Battery Electric 6x2 Tag Rigid - Full Air Suspension FMX 62R TE

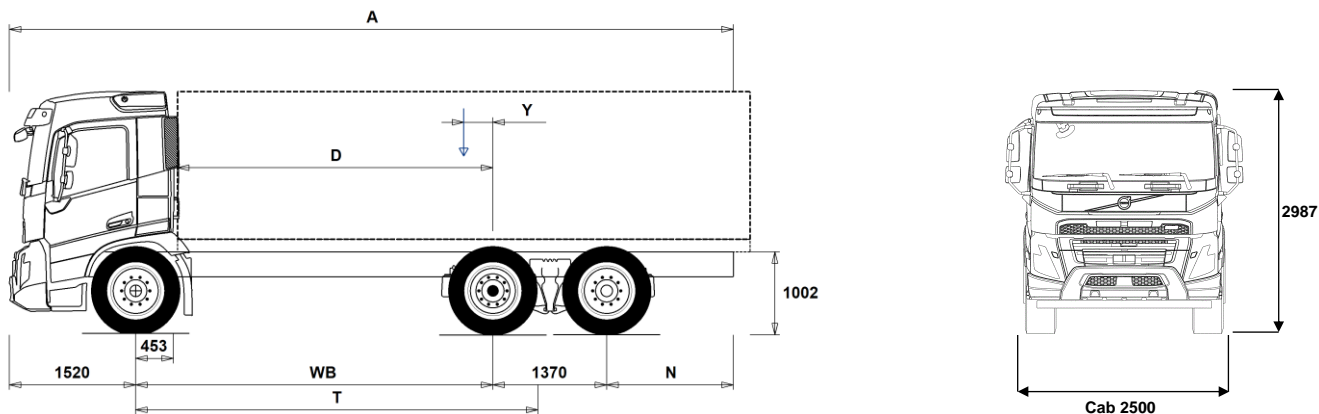

Chassis Dimensions [mm]

WB Wheelbase	3900	4100	4300	4600	4800	4900	5200	5600	6000
A Overall Chassis Length	10115	10315	9565	10015	10315	10465	10965	11565	12215
D Center of rear axle to front of body	3397	3597	3797	4097	4297	4397	4697	5097	5497
N Rear Overhang (Min.)	825	825	825	825	825	825	1225	1225	1225
N Rear Overhang (Max.)	3325	3325	2375	2525	2625	2675	2875	3075	3325
T Theoretical Wheelbase	4441	4641	4841	5141	5341	5441	5741	6141	6541
Y Center of Gravity for Payload (Min.)	-117	-122	-145	-151	-159	-161	-169	-181	-199
Y Center of Gravity for Payload (Max.)	165	173	162	176	182	186	199	213	223

Chassis Weights [kg]

Front Axle	5540	5620	5750	5840	5910	5940	6020	6115	6220
Rear Bogie	4715	4650	4495	4435	4405	4390	4355	4310	4300
Kerb Weight	10255	10270	10245	10275	10315	10330	10375	10425	10520
Payload (including body, driver, fuel, etc.)	15745	15730	15755	15725	15685	15670	15625	15575	15480

Turning Diameter [mm]

Turning Circle Diameter Kerb to Kerb	15600	16200	16800	17800	18400	18700	19600	20800	22000
Turning Circle Diameter Wall to Wall	17100	17700	18300	19300	19900	20200	21100	22300	23600

Plated Weights [kg]

	Plated	Design
Gross Vehicle Weight	26000	27000
Gross Combination Weight	32000	32000
Front Axle	8000	8000
Rear Bogie	19000	19000

Important Notes

Chassis Dimensions

Cab Height: +374 mm for CAB-HSLP, -204 mm for CAB-LDAY, -204 mm for CAB-LSLP, +4 mm for CAB-SLP.
 Front Axle to Back of Cab: +422 mm for CAB-HSLP and CAB-LSLP and CAB-SLP.
 D-measure includes a front clearance of 50 mm and for rigid trucks also a subframe of 100 mm.
 Height can vary ± 20 mm for leaf and ± 10 mm for air suspension.
 All dimensions are for unladen chassis and any tag axles down. Chassis height used: CHH-MED.
 Height change when chassis height CHH-HIGH: 0 mm.

Weight and dimensions are based upon the following tyres:
 Front Axle Tyres: 315/80R22.5
 Drive Axle Tyres: 315/80R22.5
 Trailing/Pusher Axle Tyres: 315/80R22.5

Chassis weight includes oil, water, AdBlue, 0 litres fuel and without driver. Kerb weight can vary ± 10%.

Turning diameters are theoretically calculated. Tag axle used: TA-FIXED.

Legal weights can differ from country to country.

For more detailed weight information, including optional equipment weights, ask your Volvo sales contact to enter your specification into the Volvo Weight Information system (WIS).

Do NOT use this drawing for bodybuilding. Refer to Volvo Bodybuilder Instructions and chassis assembly drawing FMX62RTE.

MODEL RANGE

NEW FMX Battery Electric 6x2 Tag Rigid - Full Air Suspension FMX 62R TE

TRUCK USE

- **RC-SMOOT** Road Conditions - Smooth
- **GARB-PRE** Transport Adaption - Refuse preparation
- **SWAPBODY** Transport Adaption - Swap body vehicle preparation
- **TIPP-PRE** Transport Adaption - Tipper vehicle preparation
- **UNIFORM** Transport Adaption - Basic platform vehicle

CORE COMPONENTS

- **CHH-HIGH** Chassis Height - High - for loading heights check the unique BEP chassis drawing attached to this quote
- **CHH-MED** Chassis Height - Medium - for loading heights check the unique BEP chassis drawing attached to this quote
- **TA-HYSB2** Tag axle - Electro-hydraulically steered
- **TAG-FIXD** Tag axle - Fixed with twin tyres on tag axle
- **TAG-FIXS** Tag axle - Fixed with single tyres on tag axle
- **RADT-GR** Rear air suspension, 2 axles - 1 driven/1 tag
- **FMXE-DAY** Cab - Day - steel safety cage design
Designed and built to Swedish impact and ECE R29 regulations
- **FMXE-HSL** Globetrotter
- **FMXE-LDA** Cab - Low Day - steel safety cage design
Designed and built to Swedish impact and ECE R29 regulations
- **FMXE-LSL** Low sleeper
- **FMXE-SLP** Cab - Sleeper - all-steel safety cage design with a roof-mounted emergency escape hatch.
Designed and built to Swedish impact and ECE R29 regulations
- **EPT2412** Gearbox - I-shift Automated 12-speed - suitable for gross train weights up to 44tonne
- **NEM2** Electric Motors - 2 - Output 330 kW - 450hp continuous power
- **NEM3** Electric Motors - 3 - Output 490 kW – 666hp continuous power
- **RSS1344C** Drive Axle - RS1344C single reduction with differential lock - design GCW 44 tonne
- **RSS1344E** Drive Axle - RSS1344E single reduction with differential lock - design GCW 44 tonne
- **RSS1370A** Drive Axle - RSS1370A single reduction 13 tonne with differential lock - design GCW 70 tonne

PACKAGES

- **INFONDF** Media Information Platform with Navigation & Volvo Connect "On board" Support
- **DRIV-E** Cab Package - Drive
- **DRIV-E+** Cab Package - Drive +
- **DRIV-E++** Cab Package - Drive ++
- **1LIVFM-E** Sleep & Resting Package - Living one-bed
- **2LIVFM-E** Sleep & Resting Package - Living two-bed
- **GSR2024** GSR2 Safety Package - includes moving off information, cyclist and pedestrian side sensors, reverse camera, driver alert support, tyre pressure monitoring, intelligent speed assist, alcohol lock preparation interface, and emergency brake lights
- **GSR2024+** GSR2 Safety Package - includes moving off information, cyclist and pedestrian side sensors, reverse camera, driver alert support, tyre pressure monitoring, intelligent speed assist, alcohol lock preparation interface, and emergency brake lights. Plus Volvo dynamic steering with lane keeping corrective steering, trailer stretch brake and adaptive cruise control
- **RANGOPT5** Range Optimisation Package - 5 years prepaid subscription

CHASSIS

- **FST-AIR** Front suspension type - Air
- **FSLs-BAS** Front suspension levelling - basic stroke
- **FSLs-HI** Front suspension levelling - high stroke for demount operations - check with bodybuilder
- **FAL10.0** Front axle design capacity - 10 tonne - check tyre capacity
- **FAL8.0** Front axle design capacity - 8.0 tonne - check tyre capacity
- **FAL8.5** Front axle design capacity - 8.5 tonnes
- **FAL9.0** Front axle design capacity - 9.0 tonne - check tyre capacity

- **FSTAB** Front anti-roll bar - Normal stiffness
- **FSTAB2** Front anti-roll bar - Medium stiffness
- **FSTAB3** Front anti-roll bar - High stiffness
- **RAL19** Rear bogie design capacity - 19 tonne
- **RAL20.5** Rear bogie design capacity - 20.5 tonne
- **RAL22.5** Rear bogie design capacity - 22.5 tonne
- **RAL23** Rear bogie design capacity - 23 tonne
- **RSTAB2** Rear anti-roll bar - Medium stiffness
- **RSTAB3** Rear anti-roll bar - Stiff
- **RALIM10** Rear-axle load limiter - 10 tonne
- **RALIM105** Rear-axle load limiter - 10.5 tonne - speed controlled
- **RALIM115** Rear-axle load limiter -11.5 tonne - speed controlled
- **RALIM20** Rear-axle load limiter - 20 tonne
- **RALIM95** Rear-axle load limiter - 9.5 tonne
- **ASF-DL1** Air suspension with 1 driving level
- **ASF-DL3** Air suspension with 3 driving levels
- **ASF-DLL** Air suspension with automatically lowered drive height over 60km/h
- **ACTST-TO** Active Steering- Volvo Dynamic Steering - VDS - with extra electronic pump and torque overlay
- **ASFE-BAS** Active steering feature - Basic - Volvo Dynamic Steering - VDS - only
- **ASFE-OG** Active steering feature - Volvo Dynamic Steering - VDS - with stability assist - oversteer
- **ASFE-PO** Active steering feature - Volvo Dynamic Steering - VDS - with personal settings and stability assist
- **ASFE-PS** Active steering feature - Volvo Dynamic Steering - VDS - with personal settings
- **RST-AIR** Rear suspension type - Air
- **RST-AIR4** Rear suspension type - Air with reinforced air bellows
- **FRAME300** Chassis frame section external height - 300 mm
- **FST8080** Chassis frame thickness - 8 mm web and flange
- **FIL-EEEB** Chassis frame inner liner - From the end of the engine to the end of the bogie
- **FIL-EEEF** Chassis frame inner liner - From the end of the engine to end of the frame
- **FIL-FBEB** Chassis frame inner liner - Over the rear bogie
- **FIL-FBEF** Chassis frame inner liner - From the front of bogie to the end of the frame
- **FIL-TXEB** Chassis frame inner liner - From gearbox member to the end of the bogie
- **FIL-TXEF** Chassis frame inner liner - From gearbox member to the end of the frame
- **BATTAMP** Battery management - Voltage and current gauge
- **BATTIND** Battery management - Voltage, current and charge indicators
- **WHC-FIX2** Wheel chocks - Two fixed design
- **WHC-FOL1** One foldable wheel chock
- **WHC-FOL2** Two foldable wheel chocks
- **WHCP-M** Wheel chock carrier position - Middle part of the vehicle
- **WHCP-R** Wheel chock carrier position - In the rear part of the vehicle
- **WHCP-T** Wheel chock carrier position - Outer luggage locker
- **SUP-BAS** Side guards - Check with bodybuilder chassis space requirements
- **CHAIN-S** Snow chains
- **HOOK-SC** Snow chain hooks
- **TOWF-HD1** Front towing device - One heavy-duty front towing device
- **TOWMBRH** Towing member, high mounted in centre of frame, D = 190
- **TOWMBRL1** Towing member, low mounted under the frame
- **TOWMBRL2** Towing member, low and forward mounted under the frame
- **TOWMBRL3** Towing member, low and far forward mounted under the frame
- **TOWMBRM** Towing member, medium mounted in line with frame lower flange
- **RFEC-L** Rear frame profile - Lower flange cut for centre axle drawbar
- **RFEC-S** Rear frame profile - Straight cut

■ Standard Equipment □ Optional Equipment

For more detailed information about cab and powertrain equipment, please refer to separate specification sheets.

For all possible options and combinations of options please consult your Volvo sales contact who can create a specification to match your requirements using the Volvo Sales Support system (VSS).

The factory reserves the right to modify design and change equipment without previous notification. The specification can vary from country to country.

MODEL RANGE

NEW FMX Battery Electric 6x2 Tag Rigid - Full Air Suspension FMX 62R TE

<input type="checkbox"/> RFEC-U	Rear frame profile - Slight uppercut for tipper	<input type="checkbox"/> HPM-F41	Hydraulic pump - F1-41 for electrical motor, fixed displacement pump
<input type="checkbox"/> C-RI4040	Towing coupling, Ringfeder 4040A	<input type="checkbox"/> HPM-F51	Hydraulic pump - F1-51 for electrical motor, fixed displacement pump
<input type="checkbox"/> C-RI5050	Towing coupling, Ringfeder 5050A	<input type="checkbox"/> HPM-F61	Hydraulic pump - F1-61 for electrical motor, fixed displacement pump
<input type="checkbox"/> C-RO400G	Towing coupling, Rockinger 400 G-150 for 40mm eyes	<input type="checkbox"/> HPM-F81	Hydraulic pump - F1-81 for electrical motor, fixed displacement pump
<input type="checkbox"/> C-RO50	Rockinger RO 50 50mm for centre axle trailer	<input type="checkbox"/> HPM-T42	Hydraulic pump - F2-42/42 for electrical motor, twin flow displacement pump
<input type="checkbox"/> C-VBG520	VBG 520D-3 coupling (Not suitable for centre axle trailers) Contact VBG on 01925 234111 to validate the coupling rating for the application	<input type="checkbox"/> HPM-T53	Hydraulic pump - F2-53/53 for electrical motor, twin flow displacement pump
<input type="checkbox"/> C-VBG795	VBG 795V-3 coupling (centre axle trailer)	<input type="checkbox"/> HPM-T55	Hydraulic pump - F2-55/28 for electrical motor, twin flow displacement pump
<input type="checkbox"/> TOWR-ONE	Towing hitch attached to rear crossmember	<input type="checkbox"/> HPM-T70	Hydraulic pump - F2-70/35 for electrical motor, twin flow displacement pump
<input type="checkbox"/> TREL-PK	Trailer electrical preparation kit - chassis/cab wiring	<input type="checkbox"/> HPM-V130	Hydraulic pump - VP1-130 for electrical motor, variable displacement pump
<input type="checkbox"/> TREL14	Single 14 pole electrical trailer connector	<input type="checkbox"/> HPM-V45	Hydraulic pump - VP1-45 for electrical motor, variable displacement pump
<input type="checkbox"/> TREL15	Trailer electrical connection - Single 15 pin - ADR certified	<input type="checkbox"/> HPM-V75	Hydraulic pump - VP1-75 for electrical motor, variable displacement pump
<input type="checkbox"/> TREL7-7	Trailer electrical connection - 2 x 7 pin - 24N and 24S	<input type="checkbox"/> HPM-V95	Hydraulic pump - VP1-95 for electrical motor, variable displacement pump
<input type="checkbox"/> TBC-DUO	Trailer brake connections - Duomatic type	<input type="checkbox"/> PTR-D	Gearbox PTO for plug-in pump, 0.71xeng speed
<input type="checkbox"/> TBC-EC	Trailer brake connections - EC palm coupling connectors	<input type="checkbox"/> PTR-DH	Gearbox driven high speed PTO for one plug-in hydraulic pump
<input type="checkbox"/> TRBR-HCF	Full pressure hand controlled trailer brake	<input type="checkbox"/> PTR-DM	Gearbox driven medium speed PTO for one plug-in hydraulic pump
<input type="checkbox"/> TRBR-STA	Stationary trailer brake control	<input type="checkbox"/> PTR-F	Gearbox driven PTO with rear flange connection
<input type="checkbox"/> TRB-STRE	Stretch Brake - Automatic low speed trailer brake activation to avoid jack-knifing and improve steerability	<input type="checkbox"/> PTR-FH	Gearbox driven high speed PTO with SAE drive flange
<input type="checkbox"/> RFEND-B	Rear mud wings - Three piece EC approved and spray flaps	<input type="checkbox"/> PTR-FL	Gearbox driven low speed PTO with SAE drive flange
<input type="checkbox"/> RFEND-T	Rear mud wings - Temporary on drive axle for transport delivery only	<input type="checkbox"/> PTRD-D	Gearbox driven HIGH SPEED PTO for two plug-in hydraulic pumps
<input type="checkbox"/> RFH-BAS	Basic rear wing height	<input type="checkbox"/> PTRD-D1	PTRD-D1 Gearbox driven HIGH SPEED PTO (1 SAE flange & 1 plug-in hydraulic pump)
<input type="checkbox"/> RFH-HIG	High rear wing height - higher wing tops	<input type="checkbox"/> PTRD-D2	Gearbox driven HIGH SPEED PTO (2 SAE flanges & 1 plug-in hyd pump)
<input type="checkbox"/> RFH-LOW	Lower rear wing height - shallower wing tops	<input type="checkbox"/> PTRD-F	PTO with 1 DIN + 1 flange connection rear, manual gearbox
<input type="checkbox"/> AUXATNK	Auxiliary airtank	<input type="checkbox"/> HPG-F101	Parker F1-101 gearbox mounted, fixed displacement, single flow, hydraulic pump
<input type="checkbox"/> RESTS-W	White conspicuity markings on chassis - sideguards, toolbox and rear overhang	<input type="checkbox"/> HPG-F41	Parker F1-41 gearbox mounted, fixed displacement, single flow, hydraulic pump
<input type="checkbox"/> REST-RUP		<input type="checkbox"/> HPG-F51	Parker F1-51 gearbox mounted, fixed displacement, single flow, hydraulic pump
<input checked="" type="checkbox"/> BLIGHT-E	Emergency brake light	<input type="checkbox"/> HPG-F61	Parker F1-61 gearbox mounted, fixed displacement, single flow, hydraulic pump
WHEELS & TYRES		<input type="checkbox"/> HPG-F81	Parker F1-81 gearbox mounted, fixed displacement, single flow, hydraulic pump
<input checked="" type="checkbox"/> RT-AL	Wheels - Howmet Alcoa brushed aluminium rims - standard holes for long stud fixing	<input checked="" type="checkbox"/> CRUIS-E	Eco cruise control (with eco-roll and I-cruise, controls in steering wheel)
<input type="checkbox"/> RT-ALDP	Wheels - Howmet Alcoa Dura-Bright aluminium rims - standard holes for long stud fixing	<input checked="" type="checkbox"/> STWPOS-R	Steering wheel position - RIGHT-HAND DRIVE
<input type="checkbox"/> RT-ALDPPD	Wheels - Howmet Alcoa Dura-Bright EVO aluminium rims - countersunk holes for short stud fixing	<input type="checkbox"/> STWM-LE	Steering wheel - Leather
<input type="checkbox"/> RT-ALDU	Wheels - Howmet Alcoa brushed aluminium rims - countersunk holes for short stud fixing	<input checked="" type="checkbox"/> STGW-AD2	Steering wheel adjustment - Neck tilt, column height and angle
<input type="checkbox"/> RT-STEEL	Wheels - Steel rims	<input type="checkbox"/> 1DAYB	One day analogue tachograph, basic
<input type="checkbox"/> SPWT-D	Spare wheel & tyre with rear tyre pattern	<input type="checkbox"/> 1DAYDIG2	Tachograph - Continental VDO 4.0
<input type="checkbox"/> SPWT-F	Spare wheel & tyre with front tyre pattern	<input checked="" type="checkbox"/> 1DAYDIG4	Smart tachograph - Continental VDO 4.1 version 2 - legal demand from 21/08/2023
<input type="checkbox"/> SWCP-R	Rear mounted spare wheel carrier	<input type="checkbox"/> TAC-PK2	Tachograph prep Kit
<input type="checkbox"/> SWCP-T	Spare wheel supplied temporarily strapped to chassis	<input type="checkbox"/> ARSL	Additional road speed limit - switch in dashboard
<input type="checkbox"/> SWCP-TP	Temporary spare wheel carrier on top of chassis frame	<input type="checkbox"/> SPEED-DU	Dual speed limiter
<input type="checkbox"/> JACK-12T	12 tonne bottle jack	<input checked="" type="checkbox"/> ESP-BAS1	Electronic Stability Control ESC
<input type="checkbox"/> JACK-15T		<input type="checkbox"/> ESPC-RO	Additional ESC functions - Reduced / Off
<input type="checkbox"/> JACK-20T		<input type="checkbox"/> HWSS-AC	Forward collision warning with adaptive cruise control WITHOUT AEBS advanced emergency brake system
<input checked="" type="checkbox"/> TOOL-BAS	Basic Toolkit	<input type="checkbox"/> HWSS-ACB	Forward collision warning with adaptive cruise control and AEBS advanced emergency brake system
<input type="checkbox"/> TOOLKIT	Complete tool kit	<input checked="" type="checkbox"/> HWSS-FCB	Forward collision warning with AEBS advanced emergency brake system
<input type="checkbox"/> INFLAHS	Tyre inflation hose		
<input type="checkbox"/> GAUGE-TP	Tyre pressure gauge		
DRIVELINE EQUIPMENT			
<input checked="" type="checkbox"/> DRM-BE	Drive Mode - Balanced & Economy		
<input checked="" type="checkbox"/> PVT-MAP	I-See Predictive Cruise Control - using map-based topography information		
<input type="checkbox"/> EPTC270	Electro-mechanical Power Take Off - Output 270 Nm - transport located on top of chassis behind cab		
<input type="checkbox"/> HPM-F101	Hydraulic pump - F1-101 for electrical motor, fixed displacement pump		
<input checked="" type="checkbox"/> Standard Equipment		<input type="checkbox"/> Optional Equipment	

For more detailed information about cab and powertrain equipment, please refer to separate specification sheets.

For all possible options and combinations of options please consult your Volvo sales contact who can create a specification to match your requirements using the Volvo Sales Support system (VSS).

The factory reserves the right to modify design and change equipment without previous notification. The specification can vary from country to country.

MODEL RANGE

NEW FMX Battery Electric 6x2 Tag Rigid - Full Air Suspension FMX 62R TE

■ LSS-DW	Lane departure-warning system	□ LBK70	Lower bunk 700 x2000 mm, fixed
■ LCS4	Side Collision Avoidance Support - passenger and driver side	□ MATL-FI	Firm lower bunk pocket sprung mattress
□ DAS-W	Driver Alert Support system	□ MATL-SF	Lower mattress - Flexi-zone semi-firm, pocket springs up to 100kg - 16 stone
□ RSENS-W	Rain sensing windscreen wipers	□ OLMAT-BA	Mattress overlay protector - 35mm thick
■ CU-ECC	Cab Climate Unit - Electrically controlled air conditioning with sun sensor	□ OLMAT-PR	Mattress overlay protector - Premium 50mm thick
□ CU-ECC2	Cab Climate Unit - Electrically controlled air conditioning with a carbon filter, sun, mist, and air quality sensor	□ TBK60F	Top bunk - Fixed foldable 600 x 1900mm
■ IMMOBIL	Thatcham H2 approved immobiliser	□ TBK70F	Top bunk - Fixed foldable 700 x 1900mm
□ ALARM-E	Enhanced vehicle alarm - Thatcham H1 approved - Cab plus external sensor for body/trailer	□ SLCP-BAS	Sleeper control panel - Basic with switches for interior light, night heater, roof hatch and door lock
□ ISUNS-BS	Side sun visor - Driver & passenger side	□ ETSB-F	Storage on engine tunnel - Central document box with two rear cup holders
■ ISUNS-DS	Side sun visor - Driver-side	□ ETSB-FR	Storage on engine tunnel - Central document box with two rear cup holders & open storage pocket on cab rear wall
□ ISUNF-RE	Electrically operated textile interior sun blind	□ ETSB-R	Storage on engine tunnel - Open storage pocket on cab rear wall
■ ISUNF-RM	Manually operated textile interior sun blind	□ RUS-BAS	Rear cab upper storage - 300 mm high
□ ADFS	Two extra DIN slots in front shelf - can be fitted with card or drawer available as an accessory	□ RUS-HIG	Rear cab upper storage - 440 mm high - volume 245 litres
■ BUPALARM	Reverse alarm	□ REF-ICPK	Fridge - Engine tunnel mounted preparation kit
□ RTOLL-PK	Road toll PREPARATION kit for trucks operating with "Toll Collect" in Germany	□ REFR-RUS	Fridge - 28 litre rear upper wall mounted with dividers
■ LOADIND	Load indicator with central dashboard display	□ MICRO-PK	Wiring preparation kit for microwave oven
□ REMC-MF	Multi-functio wireless remote control	■ BOTH-D	Bottle holder - One under dashboard centre section
■ FIREXT3S	Fire extinguisher - 3kg mounted on the seat base	□ COFMA-PK	Coffee maker - Preparation kit.
□ WARNVEST	High visibility warning vest - no sleeves	■ INLI-BAS	Interior light - White LEDs
■ WARNTRI2	Roadside hazard warning triangle	□ INLI-NL	Interior light - White and red nightlight LEDs without dimmer
□ AIDKIT	First aid kit - Legal demand for EU markets including delivery to EU bodybuilder	□ INLI-NLD	Interior light - White and red nightlight LEDs with dimmer
□ AIDKIT1B	First aid kit - Legal demand for trucks transiting Germany	□ ARL-FLEX	Flexible reading lamps - Two "snake" type
□ WARNLAMP	Portable warning lamp	■ RH-EE	Fixed tinted glass sky window with emergency exit
□ LAMP-IN	Inspection lamp	□ RH-ER	Steel roof hatch - Electrically operated, rear opening with emergency exit
□ BULBKIT	Bulb and fuse kit	□ RH-ETR	Tinted glass roof hatch - Electrically operated, rear opening with emergency exit
□ WRITEPAD	Writing pad	□ RH-MTR	Tinted glass roof hatch - Manually operated, rear opening with emergency exit
■ DST-CF4	Driver seat - Suspended, adjustable shock absorber, travel, backrest & lumbar controls with integrated seatbelt	■ GLAS-TIN	Cab windows - Tinted
□ DST-CF5	Driver seat - Suspended with adjustable shock absorber, travel, backrest, lumbar & heat controls with integrated seatbelt	□ AWIND-RF	Rear window
□ DST-CF6	Driver seat - Suspended with adjustable shock absorber, travel, backrest, lumbar, heat and ventilation controls with integrated seatbelt	□ SWIND-BS	Cab side window - On both sides behind 'B' post
□ SBD-RED	Seat belt colour - Red	□ SWIND-PS	Cab side window - Left side behind 'B' post
□ PST-BAS1	Passenger seat - Fixed non suspended fold up with seatbelt mounted on cab "B" post	□ VANMIR	Vanity mirror - In front shelf
□ PST-CF4	Passenger seat - Suspended, adjustable shock absorber, travel, backrest & lumbar controls with integrated seatbelt	□ AS-FUS	Extra shelf in front compartments
□ PST-CF5	Passenger seat - Suspended with adjustable shock absorber, travel, backrest, lumbar & heat controls with integrated seatbelt	□ INFOT-PK	Preparation kit for the mounting of a flat screen TV in cab above the driver's door, includes bracket, electrical and speaker connections
■ PST-STD2	Passenger seat - Fixed with backrest adjustment, non suspended with seatbelt mounted on cab "B" post	CAB EXTERIOR	
□ PST-STD4	Passenger seat - Standard suspended with seatbelt mounted on cab "B" post	■ EXTL-BAS	Basic exterior finish - Satin Volvo badges, grey grille, instep, bumper, bumper spoiler, grille, door handles mirror housing and sunvisor if specified.
□ SBPRE-PS	Passenger seat belt pretensioner	■ LOCK-CTL	Door locks - Central locking with key
□ ARMRE-BB	Armrests - Two on both driver & passenger seats	□ LOCK-REM	Door locks - Remote central locking
□ ARMRE-DB	Armrests - Two on the driver seat	■ BUMP-HD	Front bumper - Heavy duty - FMX
□ ARMRE-PB	Armrests - Two on the passenger seat	□ CTILT-P-E	Electrically operated hydraulic cab tilt
□ ARU-BAS	Armrest upholstery - Vinyl	■ CTILT-P-M	Manually operated hydraulic cab tilt
□ ARU-LEA	Armrest upholstery - Leather	■ FCABS-A	Front cab suspension - Air
■ FMAT-RUB	Footwell floor mats - Rubber	■ FCABS-M	Front cab suspension - Mechanical spring
□ FMAT-TX2	Footwell floor mats - Two sets, Rubber and textile with an embossed pile supplied in the cab	□ RCABS-A	Rear cab suspension - Air
		■ RCABS-M	Rear cab suspension - Mechanical spring
		■ MIRCFPCX	Mirrors - Electrically heated and operated - FMX- main and wide-angle with manually adjusted kerb view mirror on the passenger side and position camera in nearside mirror arm. To

■ Standard Equipment

□ Optional Equipment

For more detailed information about cab and powertrain equipment, please refer to separate specification sheets.

For all possible options and combinations of options please consult your Volvo sales contact who can create a specification to match your requirements using the Volvo Sales Support system (VSS).

The factory reserves the right to modify design and change equipment without previous notification. The specification can vary from country to country.

MODEL RANGE

NEW FMX Battery Electric 6x2 Tag Rigid - Full Air Suspension FMX 62R TE

	increase direct vision to the side the main mirrors have no cowlings		SRWL-2RW Chassis-mounted working lamps - Two white rear-mounted LED lamps and 3 position switch
<input type="checkbox"/> MIRFLA3		<input type="checkbox"/> SRWL-PK Chassis-mounted working lamps - Side work and reverse lamp preparation and 3 position switch - Max load 280W	
<input checked="" type="checkbox"/> AMIR-F20	Auxiliary front view mirror with a 200mm radius	<input type="checkbox"/> SWL-2FW Chassis-mounted working lamps - Two white front-mounted LED lamps	
<input type="checkbox"/> SUNV-H	External smoke grey sunvisor	<input type="checkbox"/> SWL-2RW Chassis-mounted working lamps - Two white rear-mounted LED lamps	
<input type="checkbox"/> AD-ROOF	Cab roof deflector - Adjustable	<input type="checkbox"/> SWL-4W Chassis-mounted working lamps - Four white front and rear-mounted LED lamps	
<input type="checkbox"/> AD-SIDES	Cab side deflector - Short extension panels	<input type="checkbox"/> SWL-PK Chassis-mounted working lamps - Side work lamp preparation and 2 position switch - Max load 280W	
<input type="checkbox"/> AD-CHASX	Chassis side skirts	<input type="checkbox"/> WLC-H2A Two H3/70W working lamps with amber coloured lens high mounted back of cab	
<input type="checkbox"/> ADCF-F	Additional black edging on chassis side skirt	<input type="checkbox"/> WLC-H2W Two H3/70W white working lamps high mounted on the back of cab	
<input type="checkbox"/> HLP-ST	Headlamp protection	<input type="checkbox"/> WLC-PKCH Working lamp back of cab - Preparation kit - cables and switch	
<input type="checkbox"/> HLP-ST2	Mesh headlamp protection	<input type="checkbox"/> WLC-PKH Preparation kit, cables and switch for high mounted working lamps back of cab	
<input checked="" type="checkbox"/> DRL-LED	V-shaped daytime running lights	<input type="checkbox"/> WLC-PKL Preparation kit, cables and switch for low mounted working lamps back of cab	
<input type="checkbox"/> ASL-RF2	Two Hella H11 70W spotlamps in sign box	<input type="checkbox"/> WLC-PKLH Preparation kit - cables and switch for low and high mounted working lamps back of cab.	
<input type="checkbox"/> BEACOA2F	Roof beacons - Two front roof mounted amber LED	<input checked="" type="checkbox"/> ECBB-HIG Body builder electrical centre with body builder module	
<input type="checkbox"/> BEACOA2R	Roof beacons - Two rear roof mounted amber LED	<input checked="" type="checkbox"/> BBCHAS1 One 7-pole connector for Body builder interface	
<input type="checkbox"/> BEACON-P	Roof beacons - switch and wiring preparation only	<input type="checkbox"/> BBCHAS3 Three 7-pole connectors for Body builder interface	
<input type="checkbox"/> BEACONA4	Roof beacons - Four amber LED - two front/ two rear	<input type="checkbox"/> BEPR-T2 Body builder electrical software preparation for tipper with remote control	
<input type="checkbox"/> CABPT-R1	Single outlet for roof mounted accessories	<input type="checkbox"/> EXSTER External steering control - Volvo dynamic steering and bodybuilder module prepared for external control system, installed and computer by bodybuilder	
<input checked="" type="checkbox"/> CABPT-R2	Twin outlets for roof mounted accessories.	<input type="checkbox"/> TD-BAS Trailer detection WITHOUT LED sensing	
<input type="checkbox"/> SPOTP-F	Spotlamp preparation in front, max 280W	<input type="checkbox"/> TD-LED Trailer detection with LED sensing	
<input type="checkbox"/> SPOTP-R	Spotlamp preparation on roof, max 280W	<input type="checkbox"/> FBA-BTF Lower front body attachments for torsionally flexible - platform body	
<input type="checkbox"/> SPOTP-RF	Spotlamp preparation on cab roof and in cab front, max 2x280W	<input type="checkbox"/> FBA-BTSF Lower front body attachments for torsionally semi-flexible body - box or curtainsider	
<input type="checkbox"/> ROS-IL	Globetrotter roof sign illuminated	<input type="checkbox"/> HBA-FSFB Holes for body attachments - flexible/semi-flexible body	
<input type="checkbox"/> ROS-IL2	Preparation kit for illuminated roof sign with switch loose in cab, fit after registration	<input type="checkbox"/> HBA-SB Holes for body attachments - stiff body	
<input type="checkbox"/> ROS-ILP	Roof sign illumination preparation kit	<input type="checkbox"/> RBA-T2 Lower rear body attachments for helper frame	
<input type="checkbox"/> CSGN-FMX	"Volvo FMX" headboard logo	<input type="checkbox"/> CRANEPK1 Crane plates mounted to frame, for cranes up to 10 tonne metre capacity	
<input checked="" type="checkbox"/> HORN-F1S	Horn - Air single tone - chassis mounted	<input type="checkbox"/> CRANEPK2 Crane plates mounted to frame, for cranes up to 20 tonne metre capacity	
<input type="checkbox"/> HORN-R2S	Horn - Air - Two roof-mounted	<input type="checkbox"/> CRANEPK4 Crane plates mounted to frame, for cranes up to 40 tonne metre capacity	
<input type="checkbox"/> ANT-CBR	Roof mounted antenna for CB radio, single aerial. Only Globetrotter cabs brings in extra DIN slots.	<input type="checkbox"/> AUXL-SPK Electrical preparation kit - wiring and switch for snow plough lights	
<input type="checkbox"/> ACCBR-AP	Front, middle & rear roof mounted accessory brackets	<input type="checkbox"/> TAILPRE2 Tail lift preparation kit, wireless remote operation	
<input type="checkbox"/> ACCBR-F	Front roof mounted accessory bracket	<input type="checkbox"/> TAILPREP Taillift preparation kit - cab switch and warning in driver display	
<input type="checkbox"/> ACCBR-FM	Front & middle roof mounted accessory brackets	<input type="checkbox"/> AESW2 Two Body builder bistable electrical switches (marked AUX1 / AUX2)	
<input type="checkbox"/> ACCBR-FR	Front & rear roof mounted accessory brackets	<input type="checkbox"/> AESW2PK 2 Body builder bistable el.switches (marked AUX1/AUX2) and prep. for 4 more switches	
<input type="checkbox"/> ACCBR-M	Middle roof mounted accessory bracket	<input type="checkbox"/> AUXSW-4 Wiring for 4 extra switches (from Body builder electrical centre to switch positions)	
<input type="checkbox"/> ACCBR-R	Rear roof mounted accessory bracket		
<input type="checkbox"/> ACCBR-RM	Rear & middle roof mounted accessory brackets		
<input type="checkbox"/> REFS-CW	White cab conspicuity markings mounted on cab side		
<input type="checkbox"/> REFS-TW	White cab conspicuity markings by packed in cab		
<input type="checkbox"/> REFS-TY	Yellow cab conspicuity markings by packed in cab		

SUPERSTRUCTURE PREPARATIONS

<input type="checkbox"/> SW745-EE	Swapbody equipped with front stop block for wheelbase 4600 mm and body length 7150/7450 mm. Height 130 mm above frame.
<input type="checkbox"/> SW745-FE	Swapbody equipped with front stop block for wheelbase 4800 mm and body length 7150/7450 mm. Height 130 mm above frame.
<input type="checkbox"/> SW745-GE	Swapbody equipped with front stop block for wheelbase 4600 mm and body length 7150/7450 mm. Height 190 mm above frame.
<input type="checkbox"/> SW745-HE	Swapbody equipped with front stop block for wheelbase 4800 mm and body length 7150/7450 mm. Height 130 mm above frame.
<input type="checkbox"/> SW782-ME	Swapbody equipped with front stop block for wheelbase 4900 mm and body length 7150/7450/7820 mm. Height 130 mm above frame.
<input type="checkbox"/> SW782-OE	Swapbody equipped with front stop block for wheelbase 4900 mm and body length 7150/7450/7820 mm. Height 190 mm above frame.
<input type="checkbox"/> CROSSRE	Cross reinforcement for swapbody

Standard Equipment Optional Equipment

For more detailed information about cab and powertrain equipment, please refer to separate specification sheets.

For all possible options and combinations of options please consult your Volvo sales contact who can create a specification to match your requirements using the Volvo Sales Support system (VSS).

The factory reserves the right to modify design and change equipment without previous notification. The specification can vary from country to country.

MODEL RANGE

NEW FMX Battery Electric 6x2 Tag Rigid - Full Air Suspension FMX 62R TE

- **DRUT4**
For mobile phone, tablet, with android and IOS systems.
Only available with Volvo Connect subscription
Driver utility app - "My Truck" - 4 year subscription
For mobile phone, tablet, with android and IOS systems.
- **DRUT5**
Only available with Volvo Connect subscription
Driver utility app - "My Truck" - 5 year subscription
For mobile phone, tablet, with android and IOS systems.
Only available with Volvo Connect subscription