

MODEL RANGE

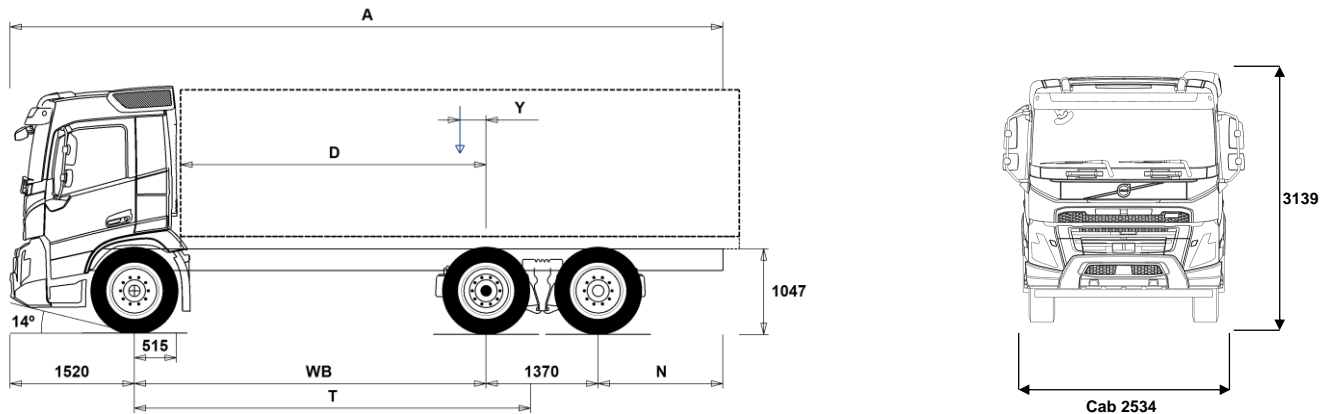

Volvo Trucks. Driving Progress

NEW FMX11 6x2 Tag Rigid - Rear Air Suspension FMX 62R T1A



Chassis Dimensions [mm]

WB Wheelbase	3500	3700	3900	4300	4600	4800	4900	5200	5600	6000
A Overall Chassis Length	7915	8115	8315	8715	9015	9215	9315	9615	10015	10415
D Center of rear axle to front of body	2935	3135	3335	3735	4035	4235	4335	4635	5035	5435
N Rear Overhang (Min.)	1225	1225	1225	1225	1225	1225	1225	1225	1225	1225
N Rear Overhang (Max.)	1525	1525	1525	1525	1525	1525	1525	1525	1525	1525
T Theoretical Wheelbase	4041	4241	4441	4841	5141	5341	5441	5741	6141	6541
Y Center of Gravity for Payload (Min.)	52	78	105	155	192	218	231	269	317	367
Y Center of Gravity for Payload (Max.)	266	303	340	413	467	503	522	577	647	719

Chassis Weights [kg]

Front Axle	4270	4285	4295	4335	4360	4370	4375	4390	4420	4445
Rear Bogie	2865	2870	2870	2900	2910	2915	2920	2925	2945	2970
Kerb Weight	7135	7155	7165	7235	7270	7285	7295	7315	7365	7415
Payload (including body, driver, fuel, etc.)	18865	18845	18835	18765	18730	18715	18705	18685	18635	18585

Turning Diameter [mm]

Turning Circle Diameter Kerb to Kerb	14400	15000	15600	16800	17800	18400	18700	19600	20800	22000
Turning Circle Diameter Wall to Wall	15900	16500	17100	18300	19300	19900	20200	21100	22300	23600

Plated Weights [kg]

	Plated	Design
Gross Vehicle Weight	26000	27000
Gross Combination Weight	44000	44000
Front Axle	8000	8000
Rear Bogie	19000	19000

Important Notes

Chassis Dimensions

Cab Height: +328 mm for CAB-HSLP, -262 mm for CAB-LDAY, -262 mm for CAB-LSLP, +16 mm for CAB-SLP.

Front Axle to Back of Cab: +431 mm for CAB-HSLP and CAB-SLP, -69 mm for CAB-LDAY, +425 mm for CAB-LSLP.

D-measure includes a front clearance of 50 mm and for rigid trucks also a subframe of 100 mm.

Height can vary ± 20 mm for leaf and ± 10 mm for air suspension.

All dimensions are for unladen chassis and any tag axles down. Chassis height used: CHH-HIGH.

Rear overhang used for vehicle weight calculation is the maximum rear overhang (N Max.) for selected wheelbase.

Height change when chassis height CHH-MED,FRAME266: 0 mm.

Weight and dimensions are based upon the following tyres:

Front Axle Tyres:	315/80R22.5
Drive Axle Tyres:	315/80R22.5
Trailing/Pusher Axle Tyres:	315/80R22.5

Chassis weight includes oil, water, AdBlue, 0 litres fuel and without driver. Kerb weight can vary $\pm 3\%$.

Turning diameters are theoretically calculated. Tag axle used: TA-FIXED.

Legal weights can differ from country to country.

For more detailed weight information, including optional equipment weights, ask your Volvo sales contact to enter your specification into the Volvo Weight Information system (WIS).

Do NOT use this drawing for bodybuilding. Refer to Volvo Bodybuilder Instructions and chassis assembly drawing FMX62RT1A.

MODEL RANGE

NEW FMX11 6x2 Tag Rigid - Rear Air Suspension FMX 62R T1A

TRUCK USE

- RC-ROUGH** Road conditions - On / off-road
- RC-SMOOT** Road Conditions - Smooth
- GARB-PRE** Transport Adaption - Refuse preparation
- SWAPBODY** Transport Adaption - Swap body vehicle preparation
- TIPP-PRE** Transport Adaption - Tipper vehicle preparation
- UNIFORM** Transport Adaption - Basic platform vehicle

CORE COMPONENTS

- CHH-HIGH** Chassis Height - High - for loading heights check the unique BEP chassis drawing
- CHH-MED** Chassis Height - Medium - for loading heights check the unique BEP chassis drawing
- TA-HYSBS** Tag axle - Electro-hydraulically steered
- TAG-FIXD** Tag axle - Fixed with twin tyres on tag axle
- TAG-FIXS** Tag axle - Fixed with single tyres on tag axle
- RADT-GR** Rear air suspension, 2 axles - 1 driven/1 tag
- FMX-CREW** Cab - Fire four-door crew for up to 9 people
- FMX-DAY5** Cab - Day - with steel safety cage design
Designed and built to Swedish impact and ECE R29 regulations
- FMX-HSL5** Cab - Globetrotter - with steel safety cage design
Designed and built to Swedish impact and ECE R29 regulations
- FMX-LDA5** Cab - Low Day - with steel safety cage design
Designed and built to Swedish impact and ECE R29 regulations
- FMX-LSL5** Cab - Low Sleeper - all-steel safety cage design.
Built to Swedish impact and ECE R29 regulations
- FMX-SLP5** Cab - Sleeper - with steel safety cage design
Designed and built to Swedish impact and ECE R29 regulations
- EU6SCR** Emission level - Euro VI step E
- D11K330** Engine - D11K330 10.8 litre engine developing 330hp at 16-1900rpm.
Peak torque 1600Nm at 950-1400rpm.
- D11K380** Engine - D11K380 10.8 litre engine developing 380hp at 17-1900rpm.
Peak torque 1800Nm at 950-1400rpm.
- D11K430** D11K430 10.8 litre engine developing 430hp at 17-1800rpm.
Peak torque 2050Nm at 1058-1400rpm.
- D11K460** D11K460 10.8 litre engine developing 460hp at 16-1800rpm.
Peak torque 2200Nm at 1050-1400rpm.
- EBR-EPG** Engine Brake Type - Exhaust brake controlled by steering column switch
- EBR-EPGC** Engine Brake Type - Exhaust pressure governor for I shift gearbox
- EBR-VEB** Engine Brake Type - Volvo engine brake and exhaust pressure governor retardation 300kW
- AT2612F** Gearbox - AT2612F 12-speed "I-shift" automated mechanical suitable for gross train weights up to 60tonne only.
Refer to sales engineering when used in conjunction with a PTO
- ATO2612F** Gearbox - ATO2612F 12-speed "I-shift" overdrive automated mechanical, suitable for gross train weights up to 60tonne.
Refer to sales engineering when used in conjunction with a PTO
- PT2106** Gearbox - Powertronic automatic 6-speed, max. engine torque 2100 Nm, max. permitted GCW 100000 kg
- RSH1370F** Drive Axle - RSH1370F 13-tonne hub reduction with differential lock - design GCW 70 tonne
- RSS1344E** Drive Axle - RSS1344E single reduction with differential lock - design GCW 44 tonne
- RSS1352A** Drive Axle - RSS1352A single reduction 13 tonne with differential lock - design GCW 52 tonne
- RSS1370A** Drive Axle - RSS1370A single reduction 13 tonne with differential lock - design GCW 70 tonne
- RSS1370B** Drive Axle - RSS1370B single reduction 13 tonne with differential lock - design GCW 70 tonne

Standard Equipment

Optional Equipment

For more detailed information about cab and powertrain equipment, please refer to separate specification sheets.

For all possible options and combinations of options please consult your Volvo sales contact who can create a specification to match your requirements using the Volvo Sales Support system (VSS).

The factory reserves the right to modify design and change equipment without previous notification. The specification can vary from country to country.

PACKAGES

- FUELPACK** Long Haul Fuel Economy driving package
- DRIVE5** Drive Package
- DRIVE5+** Drive+ Package
- DRIVE5++** Drive++ Package
- 1LIVINFM** Sleep & Resting Package - Living one-bed
- 2LIVINFM** Sleep & Resting Package - Living two-bed
- INFOBAS** Basic media package without secondary display
- INFODF** Media Information Platform with Dynafleet Support
- INFOMED** Media Information Platform - Medium level
- INFONAV** Media Information Platform with Navigation
- INFONDF** Media Information Platform with Navigation & Dynafleet Support
- VISIX5** Visibility Package
- SAFE-VE** Active Safety Package
- SAFE-VE+** Active Safety+ Package
- CHASPAC** Chassis Package Rigid
- CHASSIS**
 - FST-AIR** Front suspension type - Air
 - FST-PAR** Front suspension type - 2 leaf parabolic springs
 - FST-PAR3** Front suspension type - 3 leaf parabolic springs
 - FSL5-BAS** Front suspension levelling - basic stroke
 - FSL5-HI** Front suspension levelling - high stroke for demount operations - check with bodybuilder
 - FAL10.0** Front axle design capacity - 10 tonne - check tyre capacity
 - FAL8.0** Front axle design capacity - 8.0 tonne - check tyre capacity
 - FAL8.5** Front axle design capacity - 8.5 tonnes
 - FAL9.0** Front axle design capacity - 9.0 tonne - check tyre capacity
 - FSTAB** Front anti-roll bar - Normal stiffness
 - FSTAB2** Front anti-roll bar - Medium stiffness
 - FSTAB3** Front anti-roll bar - High stiffness
 - RAL19** Rear bogie design capacity - 19 tonne
 - RAL20.5** Rear bogie design capacity - 20.5 tonne
 - RAL22.5** Rear bogie design capacity - 22.5 tonne
 - RAL23** Rear bogie design capacity - 23 tonne
 - RSTAB2** Rear anti-roll bar - Medium stiffness
 - RSTAB3** Rear anti-roll bar - Stiff
 - RALIM10** Rear-axle load limiter - 10 tonne
 - RALIM105** Rear-axle load limiter - 10.5 tonne - speed controlled
 - RALIM115** Rear-axle load limiter - 11.5 tonne - speed controlled
 - RALIM95** Rear-axle load limiter - 9.5 tonne
 - ASF-DL1** Air suspension with 1 driving level
 - ASF-DL3** Air suspension with 3 driving levels
 - ACTST-TO** Active Steering- Volvo Dynamic Steering - VDS - with extra electronic pump and torque overlay
 - ASFE-BAS** Active steering feature - Basic - Volvo Dynamic Steering - VDS - only
 - ASFE-OG** Active steering feature - Volvo Dynamic Steering - VDS - with stability assist - oversteer
 - ASFE-PO** Active steering feature - Volvo Dynamic Steering - VDS - with personal settings and stability assist
 - ASFE-PS** Active steering feature - Volvo Dynamic Steering - VDS - with personal settings
 - PSS-SING** Power steering system - Single
 - PSP-FIX** Power steering pump - Fixed displacement
 - PSP-VAR** Power steering pump - Variable displacement
 - EBS-MED** Brake package - EBS medium including "hill" hold function
 - RST-AIR** Rear suspension type - Air
 - RST-AIR4** Rear suspension type - Air with reinforced air bellows
 - FRAME266** Chassis frame section external height - 266 mm
 - FRAME300** Chassis frame section external height - 300 mm
 - FST7070** Chassis frame thickness - 7 mm web and flange

MODEL RANGE

NEW FMX11 6x2 Tag Rigid - Rear Air Suspension FMX 62R T1A

- **FST8080** Chassis frame thickness - 8 mm web and flange
- **FIL-EEEE** Chassis frame inner liner - From the end of the engine to the end of the bogie
- **FIL-EEEF** Chassis frame inner liner - From the end of the engine to end of the frame
- **FIL-TXEB** Chassis frame inner liner - From gearbox member to the end of the bogie
- **FIL-TXEF** Chassis frame inner liner - From gearbox member to the end of the frame
- **BBOX-L** Battery box position - Left hand side
- **2BAT210B** Battery Capacity - 2 x 210 Ah - Gel type
- **2BAT210C** Battery Capacity - 2 x 210 Ah - AGM Absorbent Glass-fibre Material type
- **BATTAMP** Battery management - Voltage and current gauge
- **BATTIND** Battery management - Charge indicator
- **ADR2** ADR Adaptation - For transportation of dangerous goods on the road - Note does NOT include safe loading pass package if required this is quoted separately
- **MSWI-A** Battery master switch - ADR switch circuit shut down
- **MSWI-C** Battery master switch - Chassis mounted toggle by the battery box
- **MSWI-R** Battery master switch - Key fob operated remote controlled
- **R330A71** Right fuel tank - 330litre aluminium diameter 710mm
Min volume 255l
Max volume 885l
- **UL-FUEL** Without left fuel tank
Min volume 160l
Max volume 730l
- **ADTP-L** AdBlue tank position - Chassis mounted on the left-hand side
- **ADTP-R** AdBlue tank position - Chassis mounted on the right-hand side
- **ADB048** Plastic AdBlue tank - 48 litre
- **ADB064** Plastic AdBlue tank - 64 litre
- **ADB068** Plastic AdBlue tank - 68 litre
- **ADB090** Plastic AdBlue tank - 90 litre
- **ADB100** Plastic AdBlue tank - 100 litre
- **ADTC-BF** AdBlue tank cover with satin alloy look decorative cover
- **FCAP-L** Diesel and AdBlue filler cap - Locking
- **FUFF-AS** Fuel filler - Anti-spill device
- **FUFF-ATS** Fuel filler - Anti-spill & anti-syphon device
- **ESH-LEFT** Exhaust - Horizontal silencer - left outlet
- **ESH-REAR** Exhaust - Horizontal silencer - rear outlet
- **ESH-RIGH** Exhaust - Horizontal silencer - right outlet
- **ESH-VERT** Exhaust - Horizontal silencer - vertical outlet
- **EXST-SSP** Stainless steel exhaust stack - NOT polished
- **EXST-ST** Steel exhaust stack
- **HS-NAR** Narrow heat shield
- **WHC-FIX2** Wheel chocks - Two fixed design
- **WHC-FOL2** Two foldable wheel chocks
- **WHCP-F** Wheel chock carrier position - In the front part of the vehicle
- **WHCP-M** Wheel chock carrier position - Middle part of the vehicle
- **WHCP-R** Wheel chock carrier position - In the rear part of the vehicle
- **WHCP-T** Wheel chock carrier position - Outer luggage locker
- **TB-L80** Toolbox 800 mm, left side
- **TB-R80** Toolbox 800 mm, right side
- **SUP-BAS** EC approved chassis side guards
- **CHAIN-S** Snow chains
- **HOOK-SC** Snow chain hooks
- **TOWF-HD1** Front towing device - One heavy-duty front towing device
- **TOWMBRH** Towing member, high mounted in centre of frame, D = 190
- **TOWMBRL1** Towing member, low mounted under the frame
- **TOWMBRL2** Towing member, low and forward mounted under the frame
- **TOWMBRL3** Towing member, low and far forward mounted under the frame
- **TOWMBRM** Towing member, medium mounted in line with frame lower flange
- **RFEC-L** Rear frame profile - Lower flange cut for centre axle drawbar
- **RFEC-S** Rear frame profile - Straight cut
- **RFEC-U** Rear frame profile - Slight uppercut for tippers
- **C-RI4040** Towing coupling, Ringfeder 4040 G-150
- **C-RI5055** Towing coupling, Ringfeder 5055 G-150
- **C-RO400G** Towing coupling, Rockinger 400 G-150 for 40mm eyes
- **C-RO50** Rockinger RO 50 50mm for centre axle trailer
- **TOWR-ONE** Towing hitch attached to rear crossmember
- **TREL-PK** Trailer electrical preparation kit - chassis/cab wiring
- **TREL14** Single 14 pole electrical trailer connector
- **TREL15** Trailer electrical connection - Single 15 pin - ADR certified
- **TREL7** 7 pole - 24N trailer electrical suzie
- **TREL7-7** Trailer electrical connection - 2 x 7 pin - 24N and 24S
- **TBC-DUO** Duomatic type air line connectors
- **TBC-EC** Trailer brakes with EC palm coupling connectors
- **TRBR-HCF** Full pressure hand controlled trailer brake
- **TRBR-STA** Stationary trailer brake control
- **TRB-STRE** Stretch Brake - Automatic low speed trailer brake activation to avoid jack-knifing and improve steerability
- **RUP-FOLD** Rear underrun protection - Aluminium folding EC approved
- **RFEND-B** Three piece EC approved rear mud wings and spray flaps
- **RFEND-T** Rear mud wings - Temporary on drive axle for transport delivery only
- **RFH-BAS** Basic rear wing height
- **RFH-HIG** High rear wing height - higher wing tops
- **RFH-LOW** Lower rear wing height - shallower wing tops
- **AUXATNK** Auxiliary airtank
- **ATANK-AL** Air tanks - Aluminium
- **ATANK-ST** Air tanks - Steel
- **RESTS-W** White conspicuity markings on chassis - sideguards, toolbox and rear overhang
- **REST-RUP**
- **TL-LED** Rear lights - LED
- **BLIGHT-E** Emergency brake light

WHEELS & TYRES

- **RT-AL** Wheels - Alcoa brushed aluminium rims - standard holes for long stud fixing
- **RT-ALDP** Wheels - Alcoa Dura-Bright aluminium rims - standard holes for long stud fixing
- **RT-ALDPD** Wheels - Alcoa Dura-Bright EVO aluminium rims - countersunk holes for short stud fixing
- **RT-ALDU** Wheels - Alcoa brushed aluminium rims - countersunk holes for short stud fixing
- **RT-STEEL** Wheels - Steel rims
- **WCAP** Aerodynamic hub caps
- **SPWT-D** Spare wheel & tyre with rear tyre pattern
- **SPWT-F** Spare wheel & tyre with front tyre pattern
- **SWCP-LF** Spare wheel carrier on left side of chassis ahead of rear axle
- **SWCP-R** Rear mounted spare wheel carrier
- **SWCP-T** Spare wheel supplied temporarily strapped to chassis
- **SWCP-TP** Temporary spare wheel carrier on top of chassis frame
- **JACK-12T** 12 tonne bottle jack
- **JACK-15T** 15 tonne bottle jack
- **JACK-20T** 20 tonne bottle jack
- **TOOL-BAS** Basic Toolkit
- **TOOLKIT** Complete tool kit
- **INFLAHOS** Tyre inflation hose
- **GAUGE-TP** Tyre pressure gauge

■ Standard Equipment

□ Optional Equipment

For more detailed information about cab and powertrain equipment, please refer to separate specification sheets.

For all possible options and combinations of options please consult your Volvo sales contact who can create a specification to match your requirements using the Volvo Sales Support system (VSS).

The factory reserves the right to modify design and change equipment without previous notification. The specification can vary from country to country.

MODEL RANGE

NEW FMX11 6x2 Tag Rigid - Rear Air Suspension FMX 62R T1A

DRIVELINE EQUIPMENT

- TRAP-HD** Reinforced gearbox application
- DRM-BE** Balanced & Economy Drive Mode
- DRM-E** Economy Drive Mode
- PVT-MAP** I-See Predictive Cruise Control - using map based topography information
- CRUIS-E** Eco cruise control (with eco-roll and I-cruise, controls in steering wheel)
- CRUIS-E4** Eco fleet software - with cruise speed 85, I-See and push button I-shift.
- CRUIS-E5** Eco torque software - Improved economy mode. Fuel economy optimized cruise control for I-Save
- CRUISEC** Cruise control, standard
- AMSO-AUT** Enhanced I-shift software with manual shift available in auto mode and kickdown facility on accelerator pedal
- AVO-ENH** I-Shift application software - for construction and off road applications
- APF-ENH** I-shift enhanced PTO functions
- RET-TH** Gearbox mounted retarder
- RET-TPT** Hydraulic Retarder for Powertronic gearbox
- TC-HWO** Transmission oil cooler - water to oil
- TC-MAOH2** Extra high performance transmission oil cooler - air to oil with front mounted radiator
- TC-MWO** Basic transmission oil cooler - water to oil
- 2COM1100** Air compressor - Two-cylinder 1100 litres per minute
- 2COMP900** Air compressor - Two-cylinder 900 litres per minute
- CLU-AIRC** Clutchable air compressor
- AIRIN-HI** Air intake - Roof-mounted behind cab on the left-hand side
- AIRIN-LO** Low level air intake behind cab on left hand side
- ACL1ST-S** Air filter - two-stage element
- 24AL110B** Alternator capacity - 110 amp
- 24AL120B** Alternator capacity - 120 amp alternator
- 24AL150B** Alternator capacity - 150 amp
- CCV-C** Closed crankcase engine ventilation
- CCV-OX** Closed crankcase ventilation for cold markets
- PRIM-EL** Electrical priming pump
- PRIM-MAN** Manual priming pump
- FUEQ-EH** Fuel line electric heater
- AF-R** Hot fuel recirculation heated fuel filter
- FUEFE2SW** Small engine mounted dual fuel filter with water separator
- EST-AID** Engine starting aid -Preheating element in the air inlet manifold
- 220EBH15** 220V/1.5Kw electric engine block heater
- PTER-100** Engine power-take-off - Rear-mounted with DIN100/ISO7646 flange
- PTER-DIN** Engine power-take-off - Rear-mounted with DIN5462 (female) splined shaft for a close-coupled pump
Models with 3 steering axles will use this to drive the steering pump (AUXPSP)
- PTER1400** Engine power-take-off - Rear-mounted with SAE 1410 flange
- HPE-F101** Parker F1-101, engine mounted, fixed displacement, single flow, engine mounted hydraulic pump
- HPE-F41** Parker F1-41, engine mounted, fixed displacement, single flow, engine mounted hydraulic pump
- HPE-F51** Parker F1-51, engine mounted, fixed displacement, single flow, engine mounted hydraulic pump
- HPE-F61** Parker F1-61, engine mounted, fixed displacement, single flow, engine mounted hydraulic pump
- HPE-F81** Parker F1-81, engine mounted, fixed displacement, single flow, engine mounted hydraulic pump
- HPE-T53** Parker F2-53/53, engine mounted, Fixed displacement, Twin flow engine mounted hydraulic pump
- HPE-T70** Parker F2-70/35, engine mounted, Fixed displacement, Twin flow engine mounted hydraulic pump
- HPE-V45** Parker VP1-45, variable displacement, single flow, engine mounted hydraulic pump
- HPE-V75** Parker VP1-75, variable displacement, single flow, engine mounted hydraulic pump
- PTPT-D** Powertronic PTO, 1 front/upper DIN connection for plug-in pump (max. 850 Nm)
- PTPT-F** Powertronic PTO, 1 front/upper rear facing SAE flange conn. for prop shaft (max.850 Nm)
- PTR-D** Gearbox PTO for plug-in pump, 0.71xeng speed
- PTR-DH** Gearbox driven high speed PTO for one plug-in hydraulic pump
- PTR-DM** Gearbox driven medium speed PTO for one plug-in hydraulic pump
- PTR-F** Gearbox driven PTO with rear flange connection
- PTR-FH** Gearbox driven high speed PTO with SAE drive flange
- PTR-FL** Gearbox driven low speed PTO with SAE drive flange
- PTRD-D** Gearbox driven HIGH SPEED PTO for two plug-in hydraulic pumps
- PTRD-D1** PTRD-D1 Gearbox driven HIGH SPEED PTO (1 SAE flange & 1 plug-in hydraulic pump)
- PTRD-D2** Gearbox driven HIGH SPEED PTO (2 SAE flanges & 1 plug-in hyd pump)
- PTRD-F** PTO with 1 DIN + 1 flange connection rear, manual gearbox
- HPG-F101** Parker F1-101 gearbox mounted, fixed displacement, single flow, hydraulic pump
- HPG-F41** Parker F1-41 gearbox mounted, fixed displacement, single flow, hydraulic pump
- HPG-F51** Parker F1-51 gearbox mounted, fixed displacement, single flow, hydraulic pump
- HPG-F61** Parker F1-61 gearbox mounted, fixed displacement, single flow, hydraulic pump
- HPG-F81** Parker F1-81 gearbox mounted, fixed displacement, single flow, hydraulic pump
- STWPOS-R** Steering wheel position - RIGHT-HAND DRIVE
- STWM-LE** Leather steering wheel
- STGW-AD2** Adjustable steering wheel with neck tilt
- STGW-ADJ** Adjustable steering wheel
- AIRBAG** SRS Driver's air bag
- INST-BAS** Basic level instruments
- DRC-AMII** DPF Regeneration control switch - for manual and switching off regeneration
- 1DAYDIG2** Tachograph - Continental VDO 4.0
- ARSL** Additional road speed limit - switch in dashboard
- SPEED-DU** Dual speed limiter
- ESP-BAS1** Electronic Stability Control
- ESPC-RO** ESP (Electronic Stability Program) functionality control - Reduced / Off
- HWSS-ACB** Adaptive cruise control ACC with forward collision warning and AEBS advanced emergency brake system
- HWSS-FCB** Forward collision warning with AEBS advanced emergency brake system
- LSS-DW** Lane departure-warning system
- LCS** Lane change support
- DAS-W** Driver Alert Support system
- RSENS-W** Rain sensing windscreen wipers
- CU-ECC** Cab Climate Unit - Electrically controlled air conditioning with sun sensor
- CU-ECC2** Cab Climate Unit - Electrically controlled air conditioning with a carbon filter, sun, mist, and air quality sensor
- CU-MCC** Cab Climate Unit - Manual air conditioning
- IMMOBIL** Thatcham H2 approved immobiliser

Standard Equipment

Optional Equipment

For more detailed information about cab and powertrain equipment, please refer to separate specification sheets.

For all possible options and combinations of options please consult your Volvo sales contact who can create a specification to match your requirements using the Volvo Sales Support system (VSS).

The factory reserves the right to modify design and change equipment without previous notification. The specification can vary from country to country.

MODEL RANGE

NEW FMX11 6x2 Tag Rigid - Rear Air Suspension FMX 62R T1A

<input type="checkbox"/> ALARM-E	Enhanced vehicle alarm - Thatcham H1 approved - Cab plus external sensor for body/trailer	<input type="checkbox"/> LBK70	Lower bunk 700 x2000 mm, fixed
<input type="checkbox"/> ALCOLOCK	Alcolock	<input type="checkbox"/> MATL-FI	Firm lower bunk pocket sprung mattress
<input type="checkbox"/> BUPMON	Back up monitor - Digital reverse camera, parameter & lead supplied loose in cab.	<input type="checkbox"/> MATL-SF	Lower flexizone mattress - semi-firm, pocket springs up to 100kg - 16 stone
<input type="checkbox"/> PHONE-PK	Telephone preparation kit (antenna, antenna attachm. cable incl.)	<input type="checkbox"/> OLMAT-BA	35mm mattress overlay protector
<input type="checkbox"/> ISUNS-BS	Side sun visor - Driver & passenger side	<input type="checkbox"/> OLMAT-PR	50mm premium mattress overlay protector
<input checked="" type="checkbox"/> ISUNS-DS	Side sun visor - Driver-side	<input type="checkbox"/> TBK60F	Fixed foldable top bunk 600 x 1900mm
<input type="checkbox"/> ISUNF-B	Interior front sun visor without mirror	<input type="checkbox"/> TBK70F	Fixed foldable top bunk 700 x 1900mm
<input type="checkbox"/> ISUNF-MD	Interior front sun visor with mirror on driver side	<input type="checkbox"/> PH-CAB2	1.8kW Air to air night heater
<input type="checkbox"/> ISUNF-RE	Electrically operated textile interior sun blind	<input type="checkbox"/> PH-ENGCA	Engine and cab night heater
<input checked="" type="checkbox"/> ISUNF-RM	Manually operated textile interior sun blind	<input type="checkbox"/> PH-SS	Short stop heater
<input type="checkbox"/> ADFS	Two extra DIN slots in front shelf - can be fitted with card or drawer available as an accessory	<input type="checkbox"/> SLCP-BAS	Sleeper control panel - Basic with switches for interior light, night heater, roof hatch and door lock
<input checked="" type="checkbox"/> BUPALARM	Reverse alarm	<input type="checkbox"/> ETSB-F	Storage on engine tunnel - Central document box with two rear cup holders
<input type="checkbox"/> RTOLL-PK	Road toll PREPARATION kit for trucks operating with "Toll Collect" in Germany	<input type="checkbox"/> ETSB-FR	Storage on engine tunnel - Central document box with two rear cup holders & open storage pocket on cab rear wall
<input type="checkbox"/> LOADIND	Load indicator with central dashboard display	<input type="checkbox"/> ETSB-R	Storage on engine tunnel - Open storage pocket on cab rear wall
<input type="checkbox"/> REMC-MF	Multi-functio wireless remote control	<input type="checkbox"/> RUS-BAS	Rear cab upper storage - 300 mm high
<input type="checkbox"/> FIREXT3S	Fire extinguisher - 3kg mounted on the seat base	<input type="checkbox"/> RUS-HIG	Rear cab upper storage - 440 mm high - volume 245 litres
<input type="checkbox"/> WARNVEST	High visibility warning vest - no sleeves	<input type="checkbox"/> REF-ICPK	Fridge: engine tunnel mounted preparation kit
<input type="checkbox"/> AIDKIT	First aid kit - Legal demand for EU markets including delivery to EU bodybuilder	<input type="checkbox"/> REFR-RUS	Fridge - 28 litre rear upper wall mounted with dividers
<input type="checkbox"/> AIDKIT1B	First aid kit - Legal demand for trucks transiting Germany	<input type="checkbox"/> MICRO-PK	Wiring preparation kit for microwave oven
<input type="checkbox"/> WARNLAMP	Portable warning lamp	<input type="checkbox"/> BOTH-D	One bottle holder under dashboard centre section
<input type="checkbox"/> LAMP-IN	Inspection lamp	<input type="checkbox"/> COFMA-PK	Coffee maker, preparation kit.
<input type="checkbox"/> BULBKIT	Bulb and fuse kit	<input checked="" type="checkbox"/> INLI-BAS	Interior white LED lights - basic
<input type="checkbox"/> WRITEPAD	Writing pad	<input type="checkbox"/> INLI-NL	Interior white and red night LED light with no dimmer
<input checked="" type="checkbox"/> DST-CF4	Driver seat - Suspended, adjustable shock absorber, travel, backrest & lumbar controls - seatbelt mounted to the seat	<input type="checkbox"/> INLI-NLD	Interior white and red night LED light with dimmer
<input type="checkbox"/> DST-CF5	Driver seat - Suspended with adjustable shock absorber, travel, backrest, lumbar & heat controls - seatbelt mounted to the seat	<input type="checkbox"/> ARL-FLEX	Two flexible reading lamps (snake lamps)
<input type="checkbox"/> DST-CF6	Driver seat - Suspended with adjustable shock absorber, travel, backrest, lumbar, heat and ventilation controls - seatbelt mounted to the seat	<input checked="" type="checkbox"/> RH-EE	Fixed tinted glass sky window with emergency exit
<input type="checkbox"/> SBD-RED	Seat belt colour - Red	<input type="checkbox"/> RH-ER	Steel roof hatch - Electrically operated, rear opening with emergency exit
<input type="checkbox"/> SBPRE-DS	Driver seat belt pretensioner	<input type="checkbox"/> RH-ETR	Tinted glass roof hatch - Electrically operated, rear opening with emergency exit
<input checked="" type="checkbox"/> PST-BAS1	Passenger seat - Fixed non suspended fold up with seatbelt mounted in cab	<input type="checkbox"/> RH-MTR	Tinted glass roof hatch - Manually operated, rear opening with emergency exit
<input type="checkbox"/> PST-CF4	Passenger seat - Suspended, adjustable shock absorber, travel, backrest & lumbar controls - seatbelt mounted to the seat	<input checked="" type="checkbox"/> GLAS-TIN	Tinted windows.
<input type="checkbox"/> PST-CF5	Passenger seat - Suspended with adjustable shock absorber, travel, backrest, lumbar & heat controls - seatbelt mounted to the seat	<input type="checkbox"/> SWIND-BS	Extra side window on both sides behind "B" pillar
<input type="checkbox"/> PST-STD2	Passenger seat - Fixed with backrest adjustment, non suspended with seatbelt mounted in cab	<input type="checkbox"/> SWIND-PS	Cab side window - Left side rear behind 'B' post
<input type="checkbox"/> PST-STD4	Passenger seat - Standard suspended with seatbelt mounted in cab	<input type="checkbox"/> AWIND-RF	Rear window
<input type="checkbox"/> SBPRE-PS	Passenger seat belt pretensioner	<input type="checkbox"/> VANMIR	Vanity mirror in front shelf
<input type="checkbox"/> ARMRE-BB	Armrests - Two on both driver & passenger seats	<input type="checkbox"/> AS-FUS	Extra shelf in front upper storage compartments
<input type="checkbox"/> ARMRE-DB	Armrests - Two on the driver seat	<input type="checkbox"/> INFOT-PK	Preparation kit for the mounting of a flat screen TV in cab above the driver's door, includes bracket, electrical and speaker connections
<input type="checkbox"/> ARMRE-PB	Armrests - Two on the passenger seat	CAB EXTERIOR	
<input type="checkbox"/> ARU-BAS	Armrest upholstery - Vinyl	<input checked="" type="checkbox"/> EXTL-BAS	Basic exterior finish - Satin Volvo badges, grey grille, instep, bumper, bumper spoiler, grille, door handles mirror housing and sunvisor if specified.
<input type="checkbox"/> ARU-LEA	Armrest upholstery - Leather	<input checked="" type="checkbox"/> DGLAS-H	Tempered door glass
<input checked="" type="checkbox"/> FMAT-RUB	Footwell floor mats - Rubber	<input type="checkbox"/> DGLAS-L	Laminated door glass
<input type="checkbox"/> FMAT-TX2	Footwell floor mats - Two sets, Rubber and textile with an embossed pile supplied in the cab	<input checked="" type="checkbox"/> LOCK-CTL	Door locks - Central locking with key
		<input type="checkbox"/> LOCK-REM	Door locks - Remote central locking
		<input checked="" type="checkbox"/> BUMP-HD	Heavy duty front bumper
		<input type="checkbox"/> GUARD-EH	Engine guard to protect sump and engine hoses
		<input checked="" type="checkbox"/> BUGNET	Insect screen in front of radiator
		<input type="checkbox"/> CTILT-P-E	Electrically operated hydraulic cab tilt
		<input checked="" type="checkbox"/> CTILT-P-M	Manually operated hydraulic cab tilt

Standard Equipment

Optional Equipment

For more detailed information about cab and powertrain equipment, please refer to separate specification sheets.

For all possible options and combinations of options please consult your Volvo sales contact who can create a specification to match your requirements using the Volvo Sales Support system (VSS).

The factory reserves the right to modify design and change equipment without previous notification. The specification can vary from country to country.

MODEL RANGE

NEW FMX11 6x2 Tag Rigid - Rear Air Suspension FMX 62R T1A

- FCABS-A** Front cab suspension - Air
- FCABS-M** Front cab suspension - Mechanical spring
- RCABS-A** Rear cab suspension - Air
- RCABS-M** Rear cab suspension - Mechanical spring
- MIRCFCPX** Mirrors - Electrically heated and operated - FMX- main and wide-angle with manually adjusted kerb view mirror on the passenger side and position camera in nearside mirror arm. To increase direct vision to the side the main mirrors have no cowlings
- MIRCOMFX** Electrically heated and operated -FMX- main and wide-angle mirrors with manually adjusted passenger kerb mirror, to increase direct vision to the side the main mirrors have no cowlings
- MIRSTDX2** Electrically heated -FMX- main and wide-angle mirrors with manually adjusted passenger kerb mirror, to increase direct vision to the side the main mirrors have no cowlings
- AMIR-F20** Auxiliary front view mirror with a 200mm radius
- SUNV-H** External smoke grey sunvisor
- AD-ROOF** Roof air deflector
- AD-SIDES** Short cab side air deflector for rigid bodywork
- HL-BASIC** Halogen H7 head lamps
- HL-CLEAN** Head lamp cleaner - washer jets
- HLP-ST** Headlamp protection
- HL-ADJ** Headlight adjustment - Switch in cab
- ASL-RF2** Two Hella H11 70W spotlamps in sign box - only available with the basic headlight and no lower driving lights.
- BEACOA2F** Roof beacons - Two front roof mounted amber LED
- BEACOA2R** Roof beacons - Two rear roof mounted amber LED
- BEACON-P** Roof beacons - wiring preparation only
- BEACONA4** Roof beacons - Four amber LED - two front/ two rear
- CABPT-R1** Single outlet for roof mounted accessories
- CABPT-R2** Twin outlets for roof mounted accessories.
- SPOTP-F** Spotlamp preparation in front, max 280W
- SPOTP-R** Spotlamp preparation on roof, max 280W
- SPOTP-RF** Spotlamp preparation on cab roof and in cab front, max 2x280W
- ROS-IL2** Preparation kit for illuminated roof sign with switch loose in cab, fit after registration
- CSGN-FMX** "Volvo FMX" headboard logo
- HORN-F1S** Horn - Air single tone - chassis mounted
- HORN-R2S** Horn - Air - Two roof-mounted
- ANT-CBR** Roof mounted antenna for CB radio, single aerial. Only Globetrotter cabs brings in extra DIN slots.
- ACCBR-AP** Front, middle & rear roof mounted accessory brackets
- ACCBR-F** Front roof mounted accessory bracket
- ACCBR-FM** Front & middle roof mounted accessory brackets
- ACCBR-FR** Front & rear roof mounted accessory brackets
- ACCBR-M** Middle roof mounted accessory bracket
- ACCBR-R** Rear roof mounted accessory bracket
- ACCBR-RM** Rear & middle roof mounted accessory brackets
- REFS-CW** White cab conspicuity markings mounted on cab side
- REFS-TW** White cab conspicuity markings by packed in cab
- REFS-TY** Yellow cab conspicuity markings by packed in cab
- SW745-EE** Swapbody equipped with front stop block for wheelbase 4600 mm and body length 7150/7450 mm. Height 130 mm above frame.
- SW745-FE** Swapbody equipped with front stop block for wheelbase 4800 mm and body length 7150/7450 mm. Height 130 mm above frame.
- SW745-GE** Swapbody equipped with front stop block for wheelbase 4600 mm and body length 7150/7450 mm. Height 190 mm above frame.
- SW745-HE** Swapbody equipped with front stop block for wheelbase 4800 mm and body length 7150/7450 mm. Height 130 mm above frame.
- SW782-ME** Swapbody equipped with front stop block for wheelbase 4900 mm and body length 7150/7450/7820 mm. Height 130 mm above frame.
- SW782-OE** Swapbody equipped with front stop block for wheelbase 4900 mm and body length 7150/7450/7820 mm. Height 190 mm above frame.
- CROSSRE** Cross reinforcement for swapbody
- SRWL-PK** Chassis-mounted working lamps - Side work and reverse lamp preparation and 3 position switch - Max load 280W
- SWL-2FW** Chassis-mounted working lamps - Two white front-mounted LED lamps
- SWL-2RW** Chassis-mounted working lamps - Two white rear-mounted LED lamps
- SWL-4W** Chassis-mounted working lamps - Four white front and rear-mounted LED lamps
- SWL-PK** Chassis-mounted working lamps - Side work lamp preparation and 2 position switch - Max load 280W
- WLC-H2A** Two H3/70W working lamps with amber coloured lens high mounted back of cab
- WLC-H2W** Two H3/70W white working lamps high mounted on the back of cab
- WLC-PKCH** Working lamp back of cab - Preparation kit - cables and switch
- WLC-PKH** Preparation kit, cables and switch for high mounted working lamps back of cab
- WLC-PKL** Preparation kit, cables and switch for low mounted working lamps back of cab
- WLC-PKLH** Preparation kit - cables and switch for low and high mounted working lamps back of cab.
- ECBB-HIG** Body builder electrical centre with body builder module
- BBCHAS1** One 7-pole connector for Body builder interface
- BBCHAS3** Three 7-pole connectors for Body builder interface
- BEPR-T2** Body builder electrical software preparation for tipper with remote control
- EXSTER** External steering control - Volvo dynamic steering and bodybuilder module prepared for external control system, installed and computer by bodybuilder
- TD-BAS** Trailer detection WITHOUT LED sensing
- TD-LED** Trailer detection with LED sensing
- FRFS-B5** Frame rail free space on both sides to give space for crane legs or other equipment.
- FBA-BTF** Lower front body attachments for torsionally flexible - platform body
- FBA-BTSF** Lower front body attachments for torsionally semi-flexible body - box or curtainsider
- HBA-FSFB** Holes for body attachments - flexible/semi-flexible body
- HBA-SB** Holes for body attachments - stiff body
- RBA-T2** Lower rear body attachments for helper frame
- CRANEPK1** Crane plates mounted to frame, for cranes up to 10 tonne metre capacity
- CRANEPK2** Crane plates mounted to frame, for cranes up to 20 tonne metre capacity
- CRANEPK4** Crane plates mounted to frame, for cranes up to 40 tonne metre capacity
- AUXL-SPK** Electrical preparation kit - wiring and switch for snow plough lights
- TAILPRE2** Tail lift preparation kit, wireless remote operation
- TAILPREP** Taillift preparation kit - cab switch and warning in driver display
- AESW2** Two Body builder bistable electrical switches (marked AUX1 / AUX2)

■ Standard Equipment

Optional Equipment

For more detailed information about cab and powertrain equipment, please refer to separate specification sheets.

For all possible options and combinations of options please consult your Volvo sales contact who can create a specification to match your requirements using the Volvo Sales Support system (VSS).

The factory reserves the right to modify design and change equipment without previous notification. The specification can vary from country to country.

MODEL RANGE

NEW FMX11 6x2 Tag Rigid - Rear Air Suspension FMX 62R T1A

- **AESW2PK** 2 Body builder bistable el.switches (marked AUX1/AUX2) and prep. for 4 more switches
- **AUXSW-4** Wiring for 4 extra switches (from Body builder electrical centre to switch positions)

DELIVERY SERVICES

- **TGW-4GWL** Telematics gateway - GSM/GPRS/4G modem, LTE & WLAN
- **FMS-PK** Fleet Management System gateway
- **DRUT2** Driver utility app - "My Truck" - two-year subscription
For mobile phone, tablet, with android and IOS systems.
Only available with Volvo Connect subscription

VOLVO

Volvo Truck Corporation
volvotrucks.com