

MODEL RANGE

FMX D13 44 Tractor Diesel Rear Leaf FMX 44T 3L

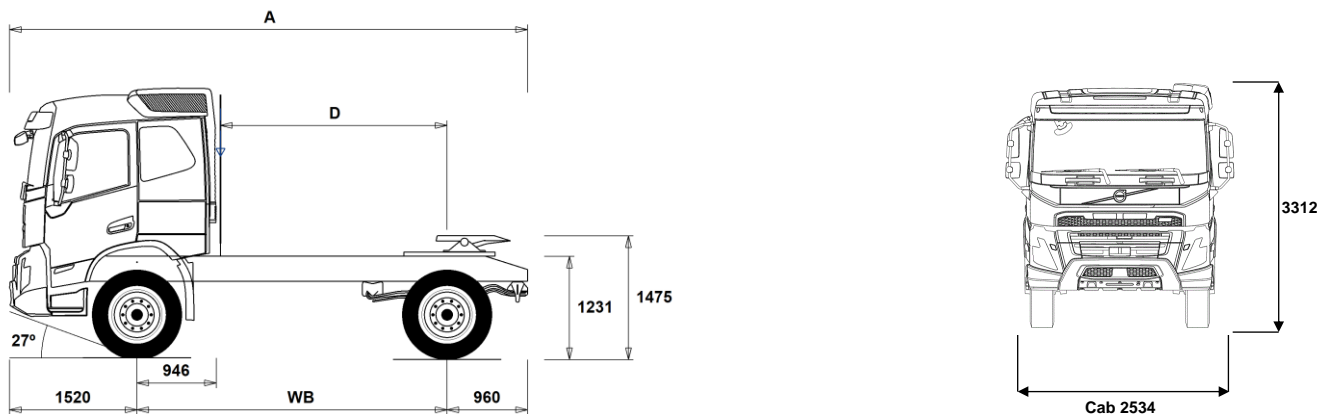

Chassis Dimensions [mm]

WB Wheelbase	3700	3800
A Overall Chassis Length	6180	6280
D Center of rear axle to back of cab	2704	2804
F Fifth Wheel Position (EC Directive 96/53)	725	725

Chassis Weights [kg]

Front Axle	5355	5360
Rear Axle	2180	2180
Kerb Weight	7535	7540

Turning Diameter [mm]

Turning Circle Diameter Kerb to Kerb	14200	14500
Turning Circle Diameter Wall to Wall	15600	15900

Plated Weights [kg]

Gross Vehicle Weight	21000
Gross Combination Weight	44000
Front Axle	8000
Rear Axle	13000

Design

Gross Vehicle Weight	21000
Gross Combination Weight	44000
Front Axle	8000
Rear Axle	13000

Important Notes

Chassis Dimensions

Cab Height: -16 mm for CAB-DAY, +312 mm for CAB-HSLP, -278 mm for CAB-LDAY, -278 mm for CAB-LSLP.

Front Axle to Back of Cab: -431 mm for CAB-DAY, -500 mm for CAB-LDAY, -6 mm for CAB-LSLP.

D-measure includes a front clearance of 50 mm and for rigid trucks also a subframe of 100 mm.

Height can vary ± 20 mm for leaf and ± 10 mm for air suspension.

All dimensions are for unladen chassis and any tag axles down.

Weight and dimensions are based upon the following tyres:

Front Axle Tyres:	315/80R22.5
Drive Axle Tyres:	315/80R22.5

Chassis weight includes oil, water, AdBlue, 0 litres fuel and without driver. Kerb weight can vary ± 3%.

Turning diameters are theoretically calculated.

Legal weights can differ from country to country.

For more detailed weight information, including optional equipment weights, ask your Volvo sales contact to enter your specification into the Volvo Weight Information system (WIS).

Do NOT use this drawing for bodybuilding. Refer to Volvo Bodybuilder Instructions and chassis assembly drawing FMX44T3L.

MODEL RANGE

FMX D13 44 Tractor Diesel Rear Leaf FMX 44T 3L

Transport operation

- **RC-ROUGH** The truck is optimised to suit the type of road the truck is going to be used on. Using the Road Condition parameter facilitates specification of frame thickness, suspension and other features.
 - For driving on badly maintained surfaced roads and hard-packed sand or gravel and other surfaces of good or bad quality. These vehicles are robust and built for long-lasting usage in tough conditions
- **RC-VROUG** The truck is optimised to suit the type of road the truck is going to be used on. Using the Road Condition parameter facilitates specification of frame thickness, suspension and other features.
 - The road condition is assessed as Very Rough if more than 5% of the total distance is covered on extremely poor roads or off-road.

Core components

- **FMX-DAY5** FMX Day cab
- **FMX-HSL5** FMX Globetrotter sleeper cab
- **FMX-LDA5** FMX Low Day cab
- **FMX-LSL5** FMX Low sleeper cab
- **FMX-SLP5** FMX Sleeper cab
- **EU6SCR** Euro 6 emission level with Selective Catalytic Reduction (SCR), particulate filter and Exhaust Gas Recirculation (EGR)
- **D13S420A** New:Diesel engine with Turbo-S, 12.8 litre Euro 6 SCR+EGR (Diesel Particulate Filter),420 hp,2100 NM
- **D13S460A** New:Diesel engine with Turbo-S, 12.8 litre Euro 6 SCR+EGR (Diesel Particulate Filter),460 hp,2300 Nm
- **D13S500A** New:Diesel engine with Turbo-S, 12.8 litre Euro 6 SCR+EGR(Diesel Particulate Filter),500 hp,2500 Nm
- **D13S540A** New:Diesel engine Turbo-S, 12.8 litre Euro 6 SCR+EGR (Diesel Particulate Filter),540 hp,2600 Nm
- **D13K420** Diesel engine, 12.8 litre Euro 6 SCR + EGR (Diesel Particulate Filter), 420 hp
- **D13K460** Diesel engine, 12.8 litre Euro 6 SCR + EGR (Diesel Particulate Filter), 460 hp
- **D13K500** Diesel engine, 12.8 litre Euro 6 SCR + EGR (Diesel Particulate Filter), 500 hp.
- **D13K540** Diesel engine, 12.8 litre Euro 6 SCR + EGR (Diesel Particulate Filter), 540 hp
- **EBR-EPG** Engine brake with exhaust pressure governor, EPG
- **EBR-EPGC** Exhaust pressure governor with Volvo compression brake
- **EBR-VEB+** Volvo Engine Brake, VEB+ (high efficiency compression brake with exhaust pressure governor, EPG)
- **AT2612** I-Shift automated mechanical 12-speed gearbox without clutch pedal, max. engine torque 2600 Nm, max.
- **ATO2612** I-Shift automated mechanical 12-speed overdrive gearbox without clutch, max. engine torque 2600 Nm, max. Suitable for hub reduction rear axles.
- **PT2606** Powertronic automatic 6-speed gearbox, max. engine torque 2600 Nm, max. permitted GCW 130000 kg
- **ASO-C** One crawler gear
- **ASO-ULC** Two crawler gears, one ultra low crawler and one crawler
- **RSH1365** Rear hub reduction solo axle - axle load 13 tonnes, GCW 65 tonnes

Packages

- **DRIVE5** Driving package
- **DRIVE5+** Driving plus package
- **DRIVE5++** Driving plus/plus package
- **1LIVINFM** Living package 1 person
- **2LIVINFM** Living package 2 persons
- **INFOBAS** Information package, basic
- **INFODF** Information package prepared for Dynafleet vehicle onboard support
- **INFOMED** Information package, medium

- **INFONAV** Information package with Navigation support
- **INFONDF** Information package with Navigation support and prepared for Dynafleet vehicle onboard support
- **VISIX5** Visibility package FMX
- **VISIXCAM**
- **GSR2024** General safety regulations 2024
- **OFFROADD** Construction package for FM/FMX day cab
- **OFFROADS** Construction package for sleeper cabs

Chassis

- **FST-PAR3** 3 leaf front parabolic suspension (stiffer than normal)
- **FAL10.0** Front axle load 10.0 tonnes
- **FAL8.0** Front axle load 8.0 tonnes
- **FAL9.0** Front axle load 9.0 tonnes
- **FSTAB** Front stabilizer with normal stiffness
- **RAL13** Rear axle load 13 tonnes
- **RSTAB1** Rear stabilizer with normal stiffness
- **PSP-FIX** Power steering pump with fixed displacement
- **PSP-VAR** Power steering pump with variable displacement
- **EBS-MED** EBS (Electronic Brake System) medium package:
 - ABS (Anti-lock Braking System)
 - Lining Wear Sensing (20 % left)
 - Lining Wear Control (incl. wear on the axle)
 - Brake Blending
 - Drag Torque Control
 - Diff Lock Synchronization
 - Diff lock Control
 - Brake Temperature Warning
 - External Brake Demand
 - Diagnosis Via Truck Electronic System
 - Traction Control System
 - Emergency Brake Assistance
 - Constant Wheel Brake Monitoring
 - Coupling Force Control
 - Automatic Parking Brake Activation
 - Lining Wear Analyses (calc of remaining mileage)
 - Auto hold
- **EBS-STD** EBS (Electronic Brake System) standard package:
 - ABS (Anti-lock Braking System)
 - Lining Wear Sensing (20 % left)
 - Lining Wear Control (incl. wear on the axle)
 - Brake Blending
 - Drag Torque Control
 - Diff Lock Synchronization
 - Diff lock Control
 - Brake Temperature Warning
 - External Brake Demand
 - Diagnosis Via Truck Electronic System
 - Traction Control System
 - Emergency Brake Assistance
 - Constant Wheel Brake Monitoring
 - Coupling Force Control
 - Automatic Parking Brake Activation
- **AUXPARK** Two extra parking brake chambers
- **RST-MUL** Rear conventional multi-leaf suspension
- **RST-PAR5** Rear progressive parabolic leaf suspension
- **FST8080** Frame section thickness - web 8.0 mm / flange 8.0 mm
- **FIL-EEEB** Frame inner liner from end of engine end to end of bogie
- **FIL-TXEB** Frame inner liner from transmission cross member to end of bogie
- **BBOX-L** Battery box on left hand side
- **2BAT210B** Gel batteries 2x210 Ah
- **2BAT210C** AGM batteries 2x210 Ah
- **BATTAMP** Battery voltage and ampere gauge
- **BATTIND** Battery voltage, ampere and battery status gauge with visual alerts

■ Standard Equipment □ Optional Equipment

For more detailed information about cab and powertrain equipment, please refer to separate specification sheets.

For all possible options and combinations of options please consult your Volvo sales contact who can create a specification to match your requirements using the Volvo Sales Support system (VSS).

The factory reserves the right to modify design and change equipment without previous notification. The specification can vary from country to country.

MODEL RANGE

FMX D13 44 Tractor Diesel Rear Leaf FMX 44T 3L

- **MSWI-C** Chassis main switch - battery box placed toggle switch circuit shut down
 - **MSWI-R** Remote controlled main switch - key fob operated circuit shut down
 - **R315A56** Right 315 litre aluminium 560 mm high D-shaped diesel tank. Usable volume is 97% of stated volume. Min volume 255l Max volume 540l
 - **ADTP-BC** AdBlue tank behind/under cab on right hand side
 - **ADTP-L** AdBlue tank on left hand side (for dual front axles between the axles)
 - **ADTP-R** AdBlue tank on right hand side
 - **ADB048** AdBlue tank usable volume 48 litres, 560 mm high mounted on chassis side.
 - **ADB050** AdBlue tank usable volume 50 litres, mounted behind cab.
 - **ADB064** AdBlue tank usable volume 64 litres, 710 mm high mounted on chassis side.
 - **ADB068** AdBlue tank usable volume 68 litres, 560 mm high mounted on chassis side.
 - **ADB083** AdBlue tank usable volume 83 litres, 560 mm high mounted on chassis side.
 - **ADB090** AdBlue tank usable volume 90 litres, 710 mm high mounted on chassis side.
 - **ADB112** AdBlue tank usable volume 112 litres, 710 mm high mounted on chassis side.
 - **FCAP-L** The variant includes two or three lockable caps, one or two for the fuel tank(s) and one for the AdBlue tank, and two keys that fit all tank locks (not cab door locks). The number of fuel tank caps are depending of how many fuel tanks that are specified.
 - **FUFF-AS** Fuel filling anti-spillage device
 - **FUFF-ATS** Fuel filling anti-theft and anti-spillage devices
 - **ESH-REAR** Horizontal muffler, rear exhaust outlet
 - **ESH-VERT** Horizontal muffler, vertical exhaust outlet on right hand side
 - **ESV-VERT** Vertical muffler, vertical exhaust outlet on right hand side
 - **EXST-SSP** Bright polished vertical stainless steel exhaust top pipe
 - **EXST-ST** Aluminized steel vertical exhaust top pipe
 - **WHC-FIX2** Two fixed wheel chocks
 - **WHC-FOL2** 2 foldable wheel chocks
 - **WHCP-F** Wheel chock(s) in the front part of the vehicle.
 - TRACTOR, BBOX-L, Fold, 1/2 w chocks = Top of left side battery box
 - TRACTOR, BBOX-EF, Fold, 1/2 w chocks = Top of lefts side fuel tank
 - TRACTOR, BBOX-EF, Fix, 2 w chocks = Left frame front of fuel tank
 - RIGID, 1 front axle, Fold, 1/2 w chocks = Top of left side battery box
 - RIGID, 2 front axles, Fold, Frame free space, 2 wc = Top of left side battery box
 - RIGID, 2 front axles, Fix, W/o frame free space, 2 wc = Left frame behind 1st front wheel
 - **WHCP-M** Wheel chock(s) in the middle part of the vehicle
 - TRACTOR, BBOX-L, Fix, 1/2 w chocks = Left frame front of rear wheels
 - RIGID, 1 front axle, Fix, 1/2 w chocks = Left frame front of (or behind) rear wheels
 - **WHCP-T** Transport mounted wheel chock(s) in cab outer luggage compartment
 - **TB-L80** Left toolbox 800 mm length (mounting length 800 mm, real length 730 mm)
 - **TB-R80** Right toolbox 800 mm length (mounting length 800 mm, real length 730 mm)
 - **CHAIN-S** The non-skid chains are on economical safety accessory that provides good grip owing to its square profile and S-shaped pattern. They are made of micro-alloy manganese steel and have a weight of 21 kg each. Using the chains does not cause any imbalance. They are supplied individually in sacks and spares are supplied with each chain. The variant includes one pair of chains except for all wheel drive 6*6, where two pairs are enclosed
 - **RFEC-B** Rear frame end, bent (standard for tractor vehicles)
 - **TOWR-ONE** One rear towing device in frame end cross member
 - **TREL15** 15 pol electrical trailer connector (ADR certified)
 - **TREL7-7** 2x7 pol (24N+24S) electrical trailer connectors (UADR)
 - **TBC-EC** Trailer brake connection, European Community
 - **TRBR-STA** Stationary trailer brake control
 - **TRB-STRE** Automatic low speed trailer brake activation (stretch brake) to avoid jack-knifing and to improve steerability
 - **RFEND-B** The fenders have a robust three-piece design with a top part that can easily be removed (no tools required) facilitating access for body building and service. The fenders are manufactured from black plastic and received in different performance to suit chassis height and tyre dimension. The fender design fulfils the technical requirements of current EU directive.
 - **RFH-BAS** Optimal fender installation (rear and 2nd front axle) with regard to legal demands, wheel/tyre sizes, chassis height and fifth wheel height.
 - **RFH-HIG** Highest fender installation (rear and 2nd front axle). Suitable for rough and very rough road conditions.
 - **RFH-LOW** Lower fender installation (rear and 2nd front axle). Suitable only for smooth road conditions. Increased risk of fender top wear.
 - **TL-LED** The LED tail lamp has all functions integrated in the lamp housing: Tail light, exterior marker light, brake light, hazard warning, reverse light, rear fog light and reflector. All light functions have LED (Light Emitting Diode) lights, which means very low energy consumption. LED lamps are insensitive to vibration and have a very long operating life. They shine with the same high intensity throughout their lifetime.
 - **BLIGHT-E** Flashing brake lights will automatically activate in emergency braking. The flashing frequency is 4 Hz and emergency braking is detected if speed exceeds 50km/h and retardation is 4 m/s² or more. The function deactivates when retardation is less than 2.5 m/s² - Easier for road users to detect emergency braking. - Contributes to safety in congested traffic
 - **FRACLOS** Frame end closing
- ### Rims and Tyres
- **RT-STEEL** Steel rims on all axles
 - **SPWT-D** Spare wheel with tyre equal to drive
 - **SPWT-F** Spare wheel with tyre equal to front wheel
 - **SWCP-T** Plastic strips strapped to the chassis are used as a temporary spare wheel carrier. Note that the mounting only is temporary and used during transportation.
 - **SWCP-TP** Plastic strips strapped to the chassis are used as a temporary spare wheel carrier. Note that the mounting only is temporary and used during transportation. An ordinary spare wheel carrier is also included. This carrier is transport mounted on top of the temporarily chassis frame strapped spare wheel.
 - **JACK-20T** The hydraulic jack has a capacity of 20 tonnes and its low manual pumping force facilitates use in uncomfortable positions. It has a release valve, which permits safe, easy and precise control over rate of lowering and a filter in the oil reservoir gives protection from contamination. The jack has a minimum height of 190 mm and a maximum

■ Standard Equipment □ Optional Equipment

For more detailed information about cab and powertrain equipment, please refer to separate specification sheets.

For all possible options and combinations of options please consult your Volvo sales contact who can create a specification to match your requirements using the Volvo Sales Support system (VSS).

The factory reserves the right to modify design and change equipment without previous notification. The specification can vary from country to country.

MODEL RANGE

FMX D13 44 Tractor Diesel Rear Leaf FMX 44T 3L

<p>height of 325 mm. Weight: 11.5 kg</p> <p>■ TOOL-BAS This kit consists of a tool bag (case) including the following tools:</p> <ul style="list-style-type: none"> • Combination screwdriver. – 1 screwdriver handle – 1 blade, Philips/flat blade – 1 blade, Torx T10/Torx T20 – 1 blade, Torx T25/Torx T27 – 1 blade, Torx T30/Torx T40 • Socket wrench. <p>□ TOOLKIT This kit consists of a tool bag (case) including the following tools:</p> <ul style="list-style-type: none"> • Combination screwdriver. – 1 screwdriver handle – 1 blade, Philips/flat blade – 1 blade, Torx T10/Torx T20 – 1 blade, Torx T25/Torx T27 – 1 blade, Torx T30/Torx T40 • Socket wrench. • Adjustable pliers. • Allen key. • Adjustable spanner. • Hammer. <p>■ INFLAHOS The tyre inflation hose is a 18 meter long air hose made of high quality rubber and equipped with nozzles on both ends. It can be used for filling air into a tyre by connecting the hose to an air tank valve on the truck. The tyre inflation hose is stored in the cab compartment for clean and easy access, either in the external luggage compartment (sleeper cab) or behind the seat (day cab).</p> <p>□ GAUGE-TP Tyre pressure gauge</p>	<p>■ AIRIN-HI High air intake</p> <p>□ AIRIN-LO Low air intake</p> <p>□ ACL1ST-S Air cleaner with additional filter element (primary + secondary)</p> <p>■ 24A110BL Alternator 110 Ampere</p> <p>□ 24A150BL Alternator 150 Ampere</p> <p>□ 24AL110B Alternator 110 Ampere</p> <p>□ 24AL150B Alternator 150 Ampere</p> <p>□ CCV-C Closed crankcase ventilation</p> <p>□ CCV-O Open crankcase ventilation</p> <p>□ PRIM-EL An electrical fuel priming pump is available for the D11 and D13 Euro 6 engines. The pump makes it faster and easier to bleed the fuel system in the case of running low on fuel or other problems with the fuel system. The priming pump is included in the fuel filter housing.</p> <p>■ PRIM-MAN An electrical fuel priming pump is available for the D11 and D13 Euro 6 engines. The pump makes it faster and easier to bleed the fuel system in the case of running low on fuel or other problems with the fuel system. The priming pump is included in the fuel filter housing.</p> <p>□ AF-E Electrically heated fuel filter</p> <p>□ AF-R Hot fuel recirculation heated fuel filter</p> <p>■ EST-AID Engine start pre-heating element</p> <p>□ 220EBH15 Engine block heater, 220 volt, 1.5 kW</p> <p>□ PTER-100 Rear engine mounted clutch independent power-take-off with flange connection (DIN 100 / ISO 7646)</p> <p>□ PTER-DIN Rear engine mounted clutch independent PTO with splined shaft groove (female) for a close coupled pump (DIN 5462 / ISO 7653)</p> <p>□ PTER1400 Rear engine mounted clutch independent power-take-off with flange connection (SAE 1410 / ISO 7647)</p> <p>□ HPE-F101 Rear engine mounted hydraulic pump F1-101, fixed displacement, single flow</p> <p>□ HPE-F41 Rear engine mounted hydraulic pump F1-41, fixed displacement, single flow</p> <p>□ HPE-F51 Rear engine mounted hydraulic pump F1-51, fixed displacement, single flow</p> <p>□ HPE-F61 Rear engine mounted hydraulic pump F1-61, fixed displacement, single flow</p> <p>□ HPE-F81 Rear engine mounted hydraulic pump F1-81, fixed displacement, single flow</p> <p>□ HPE-T53 Rear engine mounted hydraulic pump F2-53/53, fixed displacement, twin flow</p> <p>□ HPE-T70 Rear engine mounted hydraulic pump F2-70/35, fixed displacement, twin flow</p> <p>□ HPE-V45 Rear engine mounted hydraulic pump VP1-45, variable displacement, single flow</p> <p>□ HPE-V75 Rear engine mounted hydraulic pump VP1-75, variable displacement, single flow</p> <p>□ PTPT-D Automatic gearbox driven power take-off, 1 front/upper connection (DIN 5462 / ISO 7653) for plug-in pump (max. 850 Nm).</p> <p>□ PTPT-F Automatic gearbox driven Power take-off, 1 front/upper rear facing flange connection (SAE 1410 / ISO 7647) for propeller shaft (max. 850 Nm).</p> <p>□ PTR-D Mechanical gearbox driven low speed power take-off, 1 rear connection (DIN 5462 / ISO 7653) for plug-in pump (max. 1000 Nm).</p> <p>□ PTR-DH Mechanical gearbox driven high speed power take-off, 1 rear connection (DIN 5462 / ISO 7653) for plug-in pump (max. 600 Nm).</p> <p>□ PTR-DM Mechanical gearbox driven medium speed power take-off, 1 rear connection (DIN 5462 / ISO 7653) for plug-in pump (max. 600 Nm).</p> <p>□ PTR-F Mechanical gearbox driven low speed power take-off, 1 rear flange connection (SAE 1410 / ISO 7647) for propeller shaft (max. 1000 Nm).</p> <p>□ PTRD-D Mechanical gearbox driven high speed power take-off, 1 rear and 1 front connections (DIN 5462 / ISO 7653) for plug-in pumps (max. 870 Nm).</p>
---	--

■ Standard Equipment □ Optional Equipment

For more detailed information about cab and powertrain equipment, please refer to separate specification sheets.

For all possible options and combinations of options please consult your Volvo sales contact who can create a specification to match your requirements using the Volvo Sales Support system (VSS).

The factory reserves the right to modify design and change equipment without previous notification. The specification can vary from country to country.

MODEL RANGE

FMX D13 44 Tractor Diesel Rear Leaf FMX 44T 3L

<ul style="list-style-type: none"> <input type="checkbox"/> PTRD-D1 Mechanical gearbox driven high speed power take-off, 1 rear flange connection (SAE 1410 / ISO 7647) for propeller shaft / 1 front connection (DIN 5462 / ISO 7653) for plug-in pump (max. 870 Nm). <input type="checkbox"/> PTRD-D2 Mechanical gearbox driven power take-off, 2 rear flange (high-speed) connections (SAE 1310/1410 / ISO 7647) for propeller shafts / 1 front (high speed) connection (DIN 5462 / ISO 7653) for plug-in pump (max. 870/1000 Nm). <input type="checkbox"/> HPG-F101 Gearbox mounted hydraulic pump F1-101, fixed displacement, single flow <input type="checkbox"/> HPG-F41 Gearbox mounted hydraulic pump F1-41, fixed displacement, single flow <input type="checkbox"/> HPG-F51 Gearbox mounted hydraulic pump F1-51, fixed displacement, single flow <input type="checkbox"/> HPG-F61 Gearbox mounted hydraulic pump F1-61, fixed displacement, single flow <input type="checkbox"/> HPG-F81 Gearbox mounted hydraulic pump F1-81, fixed displacement, single flow 	<ul style="list-style-type: none"> ■ IMMOBIL Immobiliser <input type="checkbox"/> ALARM-E Burglar alarm - cab/body/trailer <input type="checkbox"/> PHONE-PK Telephone preparation kit (antenna, antenna attachment, cable from antenna to radio shelf). <input type="checkbox"/> ISUNS-BS Manually manoeuvred side interior sun visor (roller blind type) on both sides ■ ISUNS-DS Manually manoeuvred side interior sun visor (roller blind type) on driver side <input type="checkbox"/> ISUNF-B Interior front plastic sun visors (driver and passenger side) without mirror on driver side <input type="checkbox"/> ISUNF-MD Interior front plastic sun visors (driver and passenger side) with mirror on driver side <input type="checkbox"/> ISUNF-RE Electrical textile interior sun visor (roller blind) integrated in front shelf ■ ISUNF-RM Manual interior textile sun visor (roller-blind) integrated in front shelf <input type="checkbox"/> ADFS Two extra DIN slots in front shelf (push/pull storage), 165x40x180 mm (WxHxD) <input type="checkbox"/> BUPALARM Reversing warning unit (back-up alarm) <input type="checkbox"/> RTOLL-PK Preparation kit for road toll collect (GPS/GSM antenna and cables) <input type="checkbox"/> REMC-MF Wireless remote control - multi functional <input type="checkbox"/> FIREXT2G The fire extinguisher is an important part of the safety equipment. It is extremely reliable, has a high capacity and withstands temperatures down to -30°C. The fire extinguisher manages to extinguish fires in electrical systems and brakes. It is located on the driver side*, beside the seat, which makes it easy to reach in case of an accident. The placement of the fire extinguisher may vary depending on the specification, but it is always easily reachable by the driver. <input type="checkbox"/> FIREXT3S The fire extinguisher is an important part of the safety equipment. It is extremely reliable, has a high capacity and withstands temperatures down to -30°C. The fire extinguisher manages to extinguish fires in electrical systems and brakes. It is located on the driver side*, beside the seat, which makes it easy to reach in case of an accident. The placement of the fire extinguisher may vary depending on the specification, but it is always easily reachable by the driver. <input type="checkbox"/> WARNVEST The reflective vest makes a person clearly visible during work near a vehicle when it is dark or during other occasions when it is difficult to observe a person. It is made of yellow fluorescent textile, 100 % polyester, and it features two 50 mm wide reflective strips at the front and back. The reflective material is resistant to fuel and oil and works well in both wet and dry weather. The vest is stored in a plastic bag and it is washable at 40°C. Fulfills European standard according to EN 471 class 2. ■ WARNTR12 Warning triangles are an important safety detail. They offer extra security in the event of an unplanned stop at the roadside, when they alert other road users to be careful and slow down in the area. Two triangles give the opportunity to observe vehicles in both direction, one to be positioned ahead of the truck and the second one behind. The two triangles are delivered in the tool box behind left seat, stripes for tool bag or on the left shelf luggage compartment ■ AIDKIT The first-aid kit features a well thought-out assortment of emergency treatment products for both minor and severe injuries: <ul style="list-style-type: none"> • 1 first-aid instruction • 1 pair of scissors • 2 triangular bandage, unbleached cotton cloth • 2 pairs of protective gloves (large)
--	--

Cab Interior, Driving

- **STWPOS-L** Left hand drive
- STWM-LE** Leather steering wheel
- STGW-AD2** Mechanically adjustable steering wheel with neck tilt
- AIRBAG** Airbag on driver side
- INST-BAS** 24-HDV - Instrumentation, high performance 12" fully dynamic instrument cluster.
CLASS-HDV - Basic level instrument cluster - 4 inch monochrome display 240x320 pix
- DRC-AMII** Regeneration control of diesel filter particulates - auto initiation / manual on demand / manual inhibition
- **DRC-AUTO** Regeneration control of diesel filter particulates - fully automatic (in motion)
- 1DAYDIG2** Gen 2 one day digital tachograph, EC approved
- **1DAYDIG4** Gen 4 one day digital tachograph, EC approved
- ARSL** Additional road speed limiter (switch in dashboard)
The additional road speed limiter allows the driver to define a temporary speed limit for the truck. This is a useful feature when entering a low-speed area.
The driver activates the additional speed limiter by pressing a switch on the instrument panel and the current speed becomes the limit. The speed limiter is deactivated by pressing the switch and releasing the accelerator, lifting off to below 20% engagement.
- ESP-BAS1** Electronic Stability Program package intended for RIGID single vehicles or vehicle combinations with standard centre of gravity height when laden and for TRACTOR vehicle combinations with a single trailer or multiple trailers with ABS/EBS.
- ESPC-RO** ESP (Electronic Stability Program) functionality control - Reduced / Off
- HWSS-AC** Adaptive cruise control with forward collision warning
- HWSS-ACB** Adaptive cruise control with forward collision warning (stationary and moving objects) and emergency braking. Using both radar and camera to collect info.
- HWSS-FCB** Forward collision warning (stationary and moving objects) with emergency braking
- LSS-DW** Lane keeping support - lane departure warning system
- LCS4** Side Collision Avoidance Support, passenger and driver side
- DAS-W** Driver Alert Support (drowsy driver warning)
- RSENS-W** Wiper rain sensor
- CU-ECC** Fully electrically controlled air conditioning with sun sensor
- CU-ECC2** Fully electrically controlled air conditioning with sun sensor, mist sensor, air quality sensor and carbon filter
- **CU-MCC** Electrical manually controlled air conditioning

■ Standard Equipment □ Optional Equipment

For more detailed information about cab and powertrain equipment, please refer to separate specification sheets.

For all possible options and combinations of options please consult your Volvo sales contact who can create a specification to match your requirements using the Volvo Sales Support system (VSS).

The factory reserves the right to modify design and change equipment without previous notification. The specification can vary from country to country.

MODEL RANGE

FMX D13 44 Tractor Diesel Rear Leaf FMX 44T 3L

<ul style="list-style-type: none"> • 3 gauze bandages 80×4000 mm • 2 gauze bandages 60×4000 mm • 1 bandaging cloth 600×800 mm • 2 bandaging cloths 400×600 mm • 6 gauze dressings 100×100 mm (3×2) • 1 adhesive bandage 60×100 mm • 1 adhesive tape 25×5000 mm • 1 first-aid packet 100×120 mm • 3 first-aid packets 80×100 mm • 1 rescue sheet 1600×2100 mm (gold/silver) 	<ul style="list-style-type: none"> □ PH-SS Short stop heater □ SLCP-BAS Basic sleeper control panel (controlling interior light, parking heater, roof hatch and door lock) □ ETSB-F Storage on engine tunnel - on front top □ ETSB-FR Storage on engine tunnel - on front top and at rear cab wall □ ETSB-FRS Storage on engine tunnel - on front top & at rear cab wall & storage immersed into tunnel on RH side □ ETSB-FS Storage on engine tunnel - on front top and storage immersed into tunnel on right hand side □ ETSB-R Fixed engine tunnel storage box at rear cab wall □ ETSB-RS Storage on engine tunnel - at rear cab wall and storage immersed into tunnel on right hand side □ ETSB-S Storage on engine tunnel - immersed into tunnel on right hand side □ RUS-BAS Rear cab upper storage 154 litres (300 mm high) □ RUS-HIG Rear cab upper storage 245 litres (440 mm high) □ REF-ICPK The kit consists of a bracket that is mounted on the engine tunnel and a hook that is mounted on the refrigerator side in order to strap it down to the bracket. The kit comes with all necessary equipment for installation of both the bracket and the refrigerator. □ MICRO-PK The front shelf above the passenger seat is prepared from factory with prerouted electrical cables for installation of a 24 V microwave oven. Cables for power supply and ground connections are included. □ BOTH-D One 1.5 litre plastic soft-drink bottle holder under dashboard centre section □ COFMA-PK Preparation kit (24V) for coffee maker ■ INLI-BAS Interior white light with smooth light transition at on/off, no dimming □ INLI-NL Interior white and red (night) light with smooth light transition at on/off □ INLI-NLD Interior white and red (night) light with smooth light transition at on/off and dimmer □ ARL-FLEX Two (driver and passenger side) reading lamps with flexible arms (snake lamps) and led lamps fitted on side walls ■ RH-EE Without roof hatch, sky window / emergency exit (tinted glass) □ RH-ER Roof hatch - Electrically operated / steel / emergency exit handle □ RH-ETR Roof hatch - Electrically operated / Tinted glass / Rear opening □ RH-MTR Roof hatch - Manually operated / Tinted glass / Rear opening ■ GLAS-TIN Tinted windows (front/side/rear) □ SWIND-BS Extra side window on both sides □ SWIND-PS Rear side window on passenger side □ AWIND-RF Rear fixed window (without curtains) □ VANMIR Vanity mirror in front shelf lid. In sleeper cab on passenger side and in high/extra high cabs in middle section of the front shelf. □ AS-FUS One extra shelf in each of the two front upper storage compartments. Only 1 shelf if microwave oven mounted in one of the two compartments. □ INFOT-PK Preparation kit (bracket, security straps, power cable, antenna cable and aux cable) for mounting of a television above driver door.
<ul style="list-style-type: none"> □ AIDKIT1B First aid kit containing sticking plaster, compresses, elastic bandages, gloves, scissors, triangular bandage, bandaging cloths, adhesive tape and rescue sheet (German requirements) □ WARNLAMP Portable warning lamp with batteries □ LAMP-IN The inspection lamp is a device that is used to illuminate repairing areas during night or when the day light is not enough. It has a plug for connection into the lighter socket. The length of the electrical cable is 10 meters. The lamp is stored in a storage compartment on driver □ BULBKIT Bulb and fuse kit □ WRITEPAD Writing pad with spring-loaded paper clip 	<ul style="list-style-type: none"> □ PH-SS Short stop heater □ SLCP-BAS Basic sleeper control panel (controlling interior light, parking heater, roof hatch and door lock) □ ETSB-F Storage on engine tunnel - on front top □ ETSB-FR Storage on engine tunnel - on front top and at rear cab wall □ ETSB-FRS Storage on engine tunnel - on front top & at rear cab wall & storage immersed into tunnel on RH side □ ETSB-FS Storage on engine tunnel - on front top and storage immersed into tunnel on right hand side □ ETSB-R Fixed engine tunnel storage box at rear cab wall □ ETSB-RS Storage on engine tunnel - at rear cab wall and storage immersed into tunnel on right hand side □ ETSB-S Storage on engine tunnel - immersed into tunnel on right hand side □ RUS-BAS Rear cab upper storage 154 litres (300 mm high) □ RUS-HIG Rear cab upper storage 245 litres (440 mm high) □ REF-ICPK The kit consists of a bracket that is mounted on the engine tunnel and a hook that is mounted on the refrigerator side in order to strap it down to the bracket. The kit comes with all necessary equipment for installation of both the bracket and the refrigerator. □ MICRO-PK The front shelf above the passenger seat is prepared from factory with prerouted electrical cables for installation of a 24 V microwave oven. Cables for power supply and ground connections are included. □ BOTH-D One 1.5 litre plastic soft-drink bottle holder under dashboard centre section □ COFMA-PK Preparation kit (24V) for coffee maker ■ INLI-BAS Interior white light with smooth light transition at on/off, no dimming □ INLI-NL Interior white and red (night) light with smooth light transition at on/off □ INLI-NLD Interior white and red (night) light with smooth light transition at on/off and dimmer □ ARL-FLEX Two (driver and passenger side) reading lamps with flexible arms (snake lamps) and led lamps fitted on side walls ■ RH-EE Without roof hatch, sky window / emergency exit (tinted glass) □ RH-ER Roof hatch - Electrically operated / steel / emergency exit handle □ RH-ETR Roof hatch - Electrically operated / Tinted glass / Rear opening □ RH-MTR Roof hatch - Manually operated / Tinted glass / Rear opening ■ GLAS-TIN Tinted windows (front/side/rear) □ SWIND-BS Extra side window on both sides □ SWIND-PS Rear side window on passenger side □ AWIND-RF Rear fixed window (without curtains) □ VANMIR Vanity mirror in front shelf lid. In sleeper cab on passenger side and in high/extra high cabs in middle section of the front shelf. □ AS-FUS One extra shelf in each of the two front upper storage compartments. Only 1 shelf if microwave oven mounted in one of the two compartments. □ INFOT-PK Preparation kit (bracket, security straps, power cable, antenna cable and aux cable) for mounting of a television above driver door.
<p>Cab Interior, Living</p>	
<ul style="list-style-type: none"> ■ DST-CF1 Driver seat, comfort, suspended □ DST-CF4 Driver seat, comfort, suspended, belt in seat □ DST-CF5 Driver seat, comfort, suspended, belt in seat, electrically heated □ DST-CF6 Driver seat, comfort, suspended, belt in seat, electrically heated, ventilated □ SBD-RED A three-point safety belt is the most effective system to reduce the risk of injuries in a traffic accident. The belts keep the driver and the passenger in position and catch the body in the best possible way in case of a collision. The red coloured safety belt improves and increases the safety image for transport companies, when it thanks to the clear colour is noticed and thereby distributes good reputation. □ SBPRE-DS Driver seat belt pretensioner □ PST-BAS1 Passenger seat, basic, non suspended □ PST-CF4 Passenger seat, comfort, suspended, belt in seat □ PST-CF5 Passenger seat, comfort, suspended, belt in seat, electrically heated □ SBPRE-PS Passenger seat belt pretensioner □ ARMRE-BB Two armrests on both driver and passenger seats □ ARMRE-DB Two armrests on driver seat □ ARMRE-PB Two armrests on passenger seat □ ARU-BAS Vinyl armrest upholstery □ ARU-LEA Leather armrest upholstery ■ FMAT-RUB Two black rubber floor mats □ FMAT-TX2 Two textile (dark grey on FH/FM, black on FH16) and two black rubber floor mats ■ LBK70 Lower fixed bunk, not foldable - 2000x700 mm. Safety net included. □ MATL-FI Mattress lower bunk - firm for over approx. 100 kg, pocket springs. ■ MATL-SF Mattress lower bunk - semi-firm up to approx 100 kg, pocket springs. □ OLMAT-BA Overlay mattress protector, 28 mm thick black textile □ OLMAT-PR Overlay mattress protector, 35 mm thick black textile □ TBK60F Fixed top bunk 600x1900 mm, foldable up to 52 degrees to rear wall (depending on cab version and upper storage). Safety net included. □ TBK70F Fixed top bunk 700x1900 mm, foldable up to 52 degrees to rear wall (depending on cab version and upper storage). Safety net included. □ PH-CAB2 Cab parking heater, 2 kW □ PH-ENGCA Engine and cab parking heater 	<ul style="list-style-type: none"> □ PH-SS Short stop heater □ SLCP-BAS Basic sleeper control panel (controlling interior light, parking heater, roof hatch and door lock) □ ETSB-F Storage on engine tunnel - on front top □ ETSB-FR Storage on engine tunnel - on front top and at rear cab wall □ ETSB-FRS Storage on engine tunnel - on front top & at rear cab wall & storage immersed into tunnel on RH side □ ETSB-FS Storage on engine tunnel - on front top and storage immersed into tunnel on right hand side □ ETSB-R Fixed engine tunnel storage box at rear cab wall □ ETSB-RS Storage on engine tunnel - at rear cab wall and storage immersed into tunnel on right hand side □ ETSB-S Storage on engine tunnel - immersed into tunnel on right hand side □ RUS-BAS Rear cab upper storage 154 litres (300 mm high) □ RUS-HIG Rear cab upper storage 245 litres (440 mm high) □ REF-ICPK The kit consists of a bracket that is mounted on the engine tunnel and a hook that is mounted on the refrigerator side in order to strap it down to the bracket. The kit comes with all necessary equipment for installation of both the bracket and the refrigerator. □ MICRO-PK The front shelf above the passenger seat is prepared from factory with prerouted electrical cables for installation of a 24 V microwave oven. Cables for power supply and ground connections are included. □ BOTH-D One 1.5 litre plastic soft-drink bottle holder under dashboard centre section □ COFMA-PK Preparation kit (24V) for coffee maker ■ INLI-BAS Interior white light with smooth light transition at on/off, no dimming □ INLI-NL Interior white and red (night) light with smooth light transition at on/off □ INLI-NLD Interior white and red (night) light with smooth light transition at on/off and dimmer □ ARL-FLEX Two (driver and passenger side) reading lamps with flexible arms (snake lamps) and led lamps fitted on side walls ■ RH-EE Without roof hatch, sky window / emergency exit (tinted glass) □ RH-ER Roof hatch - Electrically operated / steel / emergency exit handle □ RH-ETR Roof hatch - Electrically operated / Tinted glass / Rear opening □ RH-MTR Roof hatch - Manually operated / Tinted glass / Rear opening ■ GLAS-TIN Tinted windows (front/side/rear) □ SWIND-BS Extra side window on both sides □ SWIND-PS Rear side window on passenger side □ AWIND-RF Rear fixed window (without curtains) □ VANMIR Vanity mirror in front shelf lid. In sleeper cab on passenger side and in high/extra high cabs in middle section of the front shelf. □ AS-FUS One extra shelf in each of the two front upper storage compartments. Only 1 shelf if microwave oven mounted in one of the two compartments. □ INFOT-PK Preparation kit (bracket, security straps, power cable, antenna cable and aux cable) for mounting of a television above driver door.
<p>Cab Exterior</p>	
<ul style="list-style-type: none"> ■ EXTL-BAS NEW-HDV: Exterior trim level basic CLASS-HDV: Basic exterior finish in a lightning grey colour of cab surrounding parts (mirror housings, insteps, bumper and fitted bumper spoiler and sun visor). If fitted roof air deflector, side air deflector and chassis fairings are always painted in cab colour. ■ DGLAS-H Tempered door glass □ DGLAS-L Laminated door glass. A laminated safety glass can crack, but retains its protective effect for much longer. This means 	<ul style="list-style-type: none"> ■ EXTL-BAS NEW-HDV: Exterior trim level basic CLASS-HDV: Basic exterior finish in a lightning grey colour of cab surrounding parts (mirror housings, insteps, bumper and fitted bumper spoiler and sun visor). If fitted roof air deflector, side air deflector and chassis fairings are always painted in cab colour. ■ DGLAS-H Tempered door glass □ DGLAS-L Laminated door glass. A laminated safety glass can crack, but retains its protective effect for much longer. This means

■ Standard Equipment □ Optional Equipment

For more detailed information about cab and powertrain equipment, please refer to separate specification sheets.

For all possible options and combinations of options please consult your Volvo sales contact who can create a specification to match your requirements using the Volvo Sales Support system (VSS).

The factory reserves the right to modify design and change equipment without previous notification. The specification can vary from country to country.

MODEL RANGE

FMX D13 44 Tractor Diesel Rear Leaf FMX 44T 3L

	reduced risk of injury in case of an accident. This glass also provides better sound insulation. The laminated door glass is tinted and has a water repellent treatment.	<input type="checkbox"/> ROS-IL	Illuminated roof sign with switch in radio shelf. Switch for turning on/off.
<input type="checkbox"/> LOCK-REM	Central door locking with remote control	<input type="checkbox"/> ROS-IL2	Preparation kit for installing an illuminated roof sign*. It includes a prerouted cable harness, a switch and LED-lamps. The switch is connected in the radio shelf middle section. Switch cap with icon, are enclosed in cab. Lamps in sign are mounted. The stripe in the Globetrotter window is selected via the cab sign variants
<input checked="" type="checkbox"/> BUMP-HD	Heavy duty front bumper	<input type="checkbox"/> ROS-ILP	Wiring preparation kit (wires and switch) for cab sign or roof air deflector illumination
<input type="checkbox"/> AUXFS	Extra cab side foot-step	<input type="checkbox"/> CSGN-FMX	FMX decal in the cab roof sign area
<input type="checkbox"/> GUARD-EH	Guard plate for cooling pipes and oil sump	<input checked="" type="checkbox"/> HORN-F1S	One front mounted (behind grille) single tone air horn, Jericho. Operated by steering wheel buttons.
<input type="checkbox"/> SIDEH-B	Guide rail on day cab driver side	<input type="checkbox"/> HORN-R2S	Two roof mounted single tone chromed air horns. Operated by steering wheel buttons.
<input type="checkbox"/> SIDSTP-R	Side ladder and guide rail on on day cab driver side	<input type="checkbox"/> ANT-CBR	Right hand side roof mounted foldable antenna and cables for CB radio, single aerial.
<input checked="" type="checkbox"/> BUGNET	Radiator screen / Mosquito net (PVC coated fibreglass) in front of radiator	<input type="checkbox"/> ACCBR-AP	Front, middle & rear roof mounted accessory brackets
<input type="checkbox"/> CTILT-P-E	Electrical cab tilt pump	<input type="checkbox"/> ACCBR-F	Front roof mounted accessory bracket
<input checked="" type="checkbox"/> CTILT-P-M	Manual cab tilt pump	<input type="checkbox"/> ACCBR-FM	Front & middle roof mounted accessory brackets
<input type="checkbox"/> FCABS-A	Air front cab suspension	<input type="checkbox"/> ACCBR-FR	Front & rear roof mounted accessory brackets
<input checked="" type="checkbox"/> FCABS-M	Mechanical cab suspension	<input type="checkbox"/> ACCBR-M	Middle roof mounted accessory bracket
<input type="checkbox"/> RCABS-A	Air rear cab suspension	<input type="checkbox"/> ACCBR-R	Rear roof mounted accessory bracket
<input checked="" type="checkbox"/> RCABS-M	Mechanical rear cab suspension	<input type="checkbox"/> ACCBR-RM	Rear & middle roof mounted accessory brackets
<input type="checkbox"/> MIRCFPCX	Electrically heated and operated rear view mirrors with a wide angle section on both sides and kerb observation mirror on the passenger side. Passenger corner camera in the mirror bracket at the passenger side.	<input type="checkbox"/> RFCAR-BC	Rear fender carrier back of cab
<input checked="" type="checkbox"/> MIRCOMFX	El heated & operated robust main rear view mirrors, electrically heated wide angle mirrors (both sides). Close view mirror on passenger side.	<input type="checkbox"/> LADDER	Ladder back of cab
<input checked="" type="checkbox"/> AMIR-F20	Front close view mirror above windscreen, passenger side (radius 200 mm)	<input type="checkbox"/> REFS-TW	Reflecting white cab side stripes by-packed in cab
<input type="checkbox"/> SUNV-H	Exterior transparent dark grey front sun visor	<input type="checkbox"/> REFS-TY	Reflecting yellow cab side stripes by-packed in cab
<input type="checkbox"/> AD-ROOF	Roof air deflector. Design (length, height etc.) automatically calculated and varies depending on vehicle total height (chassis height, cab type, tyres etc).	Superstructure preparations	
<input type="checkbox"/> AD-SIDEL	Long cab side air deflector	<input type="checkbox"/> 5WM-ISOL	Fifth wheel ISO mounting on low L-profiles (t=8 mm) with 12 mm ISO mounting plate. L-profile height above frame = 4 mm. Total height above frame 16 mm.
<input type="checkbox"/> AD-SIDES	Short cab side air deflectors	<input checked="" type="checkbox"/> 5WM-ISOM	Fifth wheel ISO mounting on medium L-profiles (t=8 mm) with 10 mm ISO tie plate. L-profile height above frame = 50 mm. Total height above frame 60 mm.
<input checked="" type="checkbox"/> HL-BASIC	Halogen H7 head lamps	<input type="checkbox"/> 5WH150	Fifth wheel leg-height 150 mm
<input type="checkbox"/> HL-CLEAN	The headlamp cleaner is a high-pressure washer unit with nozzles integrated at the side of the headlamp. It works during high- or low beam and it is activated when the windscreen wiper switch is turned on. The cleaner mainly cleans high- and low beam area	<input type="checkbox"/> 5WH185	Fifth wheel leg-height 185 mm
<input type="checkbox"/> HLP-ST	Steel headlamp protection	<input type="checkbox"/> 5WT-FO14	Fontaine 150SP2 pressed steel fixed fifth wheel
<input checked="" type="checkbox"/> HL-ADJ	The headlamp adjustment control is used to change the height of the light beam. If there is a big difference between the chassis inclination angle when loaded and unloaded, this optional feature can be operated to avoid dazzling other road users. The function is not needed when chassis height is adjusted via the air suspension system height control.	<input type="checkbox"/> 5WT-FO15	Fontaine cast iron 3000 series air actuated sliding fifth wheel. Specified fifth wheel position always gives rearmost position.
<input checked="" type="checkbox"/> DRL-LED	V-shaped ("V-light") day running light (LED). Turned on low beam gives a dimmed "V-light".	<input checked="" type="checkbox"/> 5WT-JO10	Just JSK 36 pressed steel fixed fifth wheel
<input type="checkbox"/> ASL-RF2	Two Hella H11 70W spot lamps in sign box (one on each side of the Globetrotter sign)	<input type="checkbox"/> 5WT-JO8	Just JSK 37 cast iron fixed fifth wheel
<input type="checkbox"/> BEACOA2F	Two LED warning lights on the cab front	<input type="checkbox"/> 5WT-SH	SAF-Holland/+GF+ SK-S 36.20 V cast iron fixed fifth wheel
<input type="checkbox"/> BEACOA2R	Two LED warning lights on the cab rear	<input type="checkbox"/> 5WL-S1	Fifth wheel lubrication - locking mechanism and top plate
<input type="checkbox"/> BEACON-P	Preparation kit	<input type="checkbox"/> 5WL-S2	Fifth wheel lubrication - locking mechanism
<input type="checkbox"/> BEACONA4	Four LED warning lights on the cab front-rear	<input type="checkbox"/> TCIND	Trailer connection indication with sensors for height, kingpin and coupling lock
<input type="checkbox"/> CABPT-R1	One front cab roof pass through on passenger side	<input checked="" type="checkbox"/> RDECK	Basic rear deck (one plate between frame rails and one over left fuel tank or left battery box)
<input checked="" type="checkbox"/> CABPT-R2	Two front cab roof pass throughs, one on each side	<input type="checkbox"/> RDECK-M	Medium rear deck (two plates between frame rails and one over left fuel tank or left battery box)
<input type="checkbox"/> SPOTP-F	Spotlamp preparation in cab front, max 280W	<input type="checkbox"/> SRWL-PK	Wiring preparation for chassis mounted working lamps and a 3-position switch (On/Off/Reverse auto on).
<input type="checkbox"/> SPOTP-R	Spotlamp preparation on cab roof, max 280W	<input type="checkbox"/> SWL-2RA	Two amber rear chassis-mounted (LH/RH side) LED working lamps and a 2-position switch (On/Off).
<input type="checkbox"/> SPOTP-RF	Spotlamp preparation on cab roof and in cab front, max 2x280W	<input type="checkbox"/> SWL-2RW	Two white rear chassis-mounted (LH/RH side) LED working lamps and a 2-position switch (On/Off).
		<input type="checkbox"/> SWL-PK	Wiring preparation for chassis mounted working lamps and a 2-position switch (On/Off).
		<input type="checkbox"/> WL-TA1A	Trailer arch working lamp with amber coloured lens and H3/35W bulb
		<input checked="" type="checkbox"/> WL-TA1W	Trailer arch working lamp with white lens and LED/70W bulb
		<input type="checkbox"/> WLC-H2A	Two H3/70W working lamps with amber coloured lens high mounted back of cab (switch incl).
<input checked="" type="checkbox"/> Standard Equipment	<input type="checkbox"/> Optional Equipment		

For more detailed information about cab and powertrain equipment, please refer to separate specification sheets.

For all possible options and combinations of options please consult your Volvo sales contact who can create a specification to match your requirements using the Volvo Sales Support system (VSS).

The factory reserves the right to modify design and change equipment without previous notification. The specification can vary from country to country.

MODEL RANGE

FMX D13 44 Tractor Diesel Rear Leaf FMX 44T 3L

- **WLC-H2W** Two H3/70W working lamps, white lens high mounted back of cab (switch incl).
- **WLC-PKH** Preparation kit (cables and switch) for high mounted working lamps back of cab (pass through in cab rear roof included). Max load 280W.
- **WLC-PKL** Preparation kit (cables and switch) for low mounted working lamps back of cab (pass through in cab rear wall included). Max load 280W.
- **WLC-PKLH** Preparation kit (cables and switch) for low and high mounted working lamps back of cab (pass throughs in rear wall and rear roof included). Max load 280W.
- **ECBB-BAS** Body builder electrical centre without any body builder module
- **ECBB-HIG** Body builder electrical centre with cab body builder module, 14 high and 4 low dig. outlet
- **ECBB-MED** Body builder electrical centre with cab body builder module, 7 hig and 4 low dig. outlet
- **BBCHAS1** One 7-pole connector for Body builder interface. Wiring harness routed from the bodybuilder electrical distribution box inside the cab to a connection point inside the right frame rail beside the gearbox.
- **BBCHAS3** Three 7-pole connectors for Body builder interface. Wiring harness routed from the bodybuilder electrical distribution box inside the cab to a connection point inside the right frame rail beside the gearbox.
- **BEPR-T2** Body builder electrical software preparation for tipper with remote control
- **TD-BAS** Trailer detection without LED sensor
- **TD-LED** Trailer detection with LED sensor
- **AUXL-SPK** Electrical preparation kit (wiring and a switch in dashboard) for snow plough lights. Preparation for installation of additional headlights and additional turning indicators.
- **TAILPRE2** Tail lift preparation kit, wireless remote operation
- **TAILPREP** Tail lift preparation kit, wire remote operation
- **AESW2** Two Body builder bistable electrical switches (marked AUX1 / AUX2)
- **AESW2PK** Two Body builder bistable electrical switches (marked AUX1/AUX2) and in an empty 4-group preparation another four bistable switches with dummy switch caps
- **AUXSW-4** Wiring for 4 extra hardwired switches (from Body builder electrical centre to switch positions)

Services

- **TGW-4GWL** Telematics gateway with 4G modem
- **FMS-PK** Fleet Management System gateway, preparation kit
- **DRUT1** My Truck connects the vehicle to the smartphone app, 1 year prepaid subscription
- **DRUT2** My Truck connects the vehicle to the smartphone app, 2 year prepaid subscription
- **DRUT3** My Truck connects the vehicle to the smartphone app, 3 year prepaid subscription
- **DRUT4** My Truck connects the vehicle to the smartphone app, 4 year prepaid subscription
- **DRUT5** My Truck connects the vehicle to the smartphone app, 5 year prepaid subscription