

MODEL RANGE

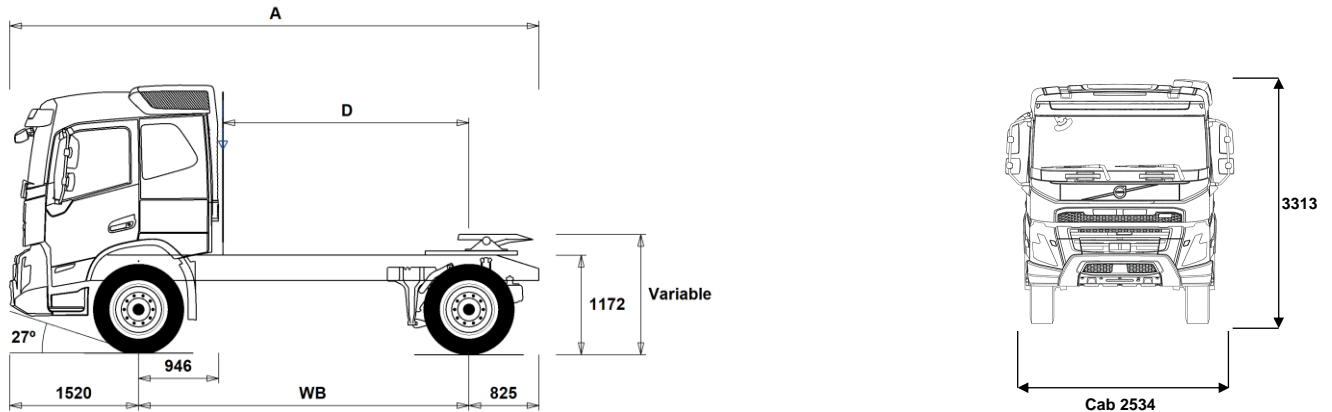

Volvo Trucks. Driving Progress

NEW FMX13 4x4 Tractor - Rear Air Suspension - N3G FMX 44T 3A



Chassis Dimensions [mm]

WB Wheelbase	3900
A Overall Chassis Length	6245
D Center of rear axle to back of cab	2904
F Fifth Wheel Position (EC Directive 96/53)	925

Chassis Weights [kg]

Front Axle	5335
Rear Axle	2335
Kerb Weight	7670

Turning Diameter [mm]

Turning Circle Diameter Kerb to Kerb	14000
Turning Circle Diameter Wall to Wall	15500

Plated Weights [kg]

	Plated	Design
Gross Vehicle Weight	18000	21000
Gross Combination Weight	40000	40000
Front Axle	8000	8000
Rear Axle	11500	13000

Important Notes

Chassis Dimensions

Cab Height: -16 mm for CAB-DAY, +312 mm for CAB-HSLP, -278 mm for CAB-LDAY, -278 mm for CAB-LSLP.

Front Axle to Back of Cab: -431 mm for CAB-DAY, -500 mm for CAB-LDAY, -6 mm for CAB-LSLP.

D-measure includes a front clearance of 50 mm and for rigid trucks also a subframe of 100 mm.

Height can vary ± 20 mm for leaf and ± 10 mm for air suspension.

All dimensions are for unladen chassis and any tag axles down.

Weight and dimensions are based upon the following tyres:

Front Axle Tyres:	315/80R22.5
Drive Axle Tyres:	315/80R22.5

Chassis weight includes oil, water, AdBlue, 0 litres fuel and without driver. Kerb weight can vary $\pm 3\%$.

Turning diameters are theoretically calculated.

Legal weights can differ from country to country.

For more detailed weight information, including optional equipment weights, ask your Volvo sales contact to enter your specification into the Volvo Weight Information system (WIS).

Do NOT use this drawing for bodybuilding. Refer to Volvo Bodybuilder Instructions and chassis assembly drawing FMX44T3A.

MODEL RANGE

NEW FMX13 4x4 Tractor - Rear Air Suspension - N3G FMX 44T 3A

CORE COMPONENTS

- **RAD-G2** Rear air suspension, 1 axle - 1 driven, high ground clearance
 - **FMX-DAY5** Cab - Day - with steel safety cage design
Designed and built to Swedish impact and ECE R29 regulations
 - **FMX-HSL5** Cab - Globetrotter - with steel safety cage design
Designed and built to Swedish impact and ECE R29 regulations
 - **FMX-LDA5** Cab - Low Day - with steel safety cage design
Designed and built to Swedish impact and ECE R29 regulations
 - **FMX-LSL5** Cab - Low Sleeper - all-steel safety cage design.
Built to Swedish impact and ECE R29 regulations
 - **FMX-SLP5** Cab - Sleeper - with steel safety cage design
Designed and built to Swedish impact and ECE R29 regulations
 - **EU6SCR** Emission level - Euro VI step E
 - **D13 420S** Engine - D13K420 12.8 litre developing 420hp at 14-1800rpm.
Peak torque 2100Nm at 860 -1400rpm.
 - **D13 460S** Engine - D13K460 12.8 litre developing 460hp at 14-1800rpm.
Peak torque 2300Nm at 900-1400rpm.
 - **D13 500S** Engine - D13K500 12.8 litre developing 500hp at 14-1800rpm.
Peak torque 2500Nm at 1000-1400rpm.
 - **D13 540S** Engine - D13K540 12.8 litre developing 540hp at 14-1800rpm.
Peak torque 2600Nm at 1000-1450rpm.
 - **D13K420** D13K420 - 420hp engine
 - **D13K460** D13K460 - 460hp engine
 - **D13K500** D13K500 - 500hp engine
 - **D13K540** D13K540 - 540hp engine
 - **EBR-EPG** Engine Brake Type - Exhaust brake controlled by steering column switch
 - **EBR-EPGC** Engine Brake Type - Exhaust pressure governor for 1 shift gearbox
 - **EBR-VEB+** Engine Brake Type - Volvo engine brake + and exhaust pressure governor, enhanced performance from additional exhaust rocker control. Retardation 375kW
 - **AT2612F** Gearbox - AT2612F 12-speed "I-shift" automated mechanical suitable for gross train weights up to 60tonne only.
Refer to sales engineering when used in conjunction with a PTO
 - **ATO2612F** Gearbox - ATO2612F 12-speed "I-shift" overdrive automated mechanical, suitable for gross train weights up to 60tonne.
Refer to sales engineering when used in conjunction with a PTO
 - **PT2606** Gearbox - Powertronic automatic 6-speed, max. engine torque 2600 Nm, max. permitted GCW 130000 kg
 - **ASO-C** Crawler gear -
Ratio direct top gearbox 19:1
Ratio Overdrive gearbox 17:1
 - **ASO-ULC** Ultra low crawler and crawler gear -
Ratios direct top gearbox 32:1 and 19:1
Ratios Overdrive box 32:1 and 17:1
 - **RSH1370F** Drive Axle - RSH1370F 13-tonne hub reduction with differential lock - design GCW 70 tonne
- ### PACKAGES
- **DRIVE5** Drive Package
 - **DRIVE5+** Drive+ Package
 - **DRIVE5++** Drive++ Package
 - **1LIVINFM** Sleep & Resting Package - Living one-bed
 - **2LIVINFM** Sleep & Resting Package - Living two-bed
 - **INFOBAS** Basic media package without secondary display
 - **INFODF** Media Information Platform with Dynafleet Support
 - **INFOMED** Media Information Platform - Medium level
 - **INFONAV** Media Information Platform with Navigation
 - **INFONDF** Media Information Platform with Navigation & Dynafleet Support
- ### CHASSIS
- **FST-PAR3** Front suspension type - 3 leaf parabolic springs
 - **FAL10.0** Front axle design capacity - 10 tonne - check tyre capacity
 - **FAL8.0** Front axle design capacity - 8.0 tonne - check tyre capacity
 - **FAL9.0** Front axle design capacity - 9.0 tonne - check tyre capacity
 - **FSM-LUB** Front suspension maintenance - Lubricated rear shackles on pins and bushings
 - **FSTAB** Front anti-roll bar - Normal stiffness
 - **RAL13** Rear axle design capacity - 13 tonne
 - **RSTAB3** Rear anti-roll bar - Stiff
 - **ASF-DL1** Air suspension with 1 driving level
 - **ASF-DL3** Air suspension with 3 driving levels
 - **PSP-FIX** Power steering pump - Fixed displacement
 - **PSP-VAR** Power steering pump - Variable displacement
 - **EBS-MED** Brake package - EBS medium including "hill" hold function
 - **AUXPARK** Auxiliary parking brake - Additional spring brakes
 - **FRAME300** Chassis frame section external height - 300 mm
 - **FST8080** Chassis frame thickness - 8 mm web and flange
 - **FIL-EEEB** Chassis frame inner liner - From the end of the engine to the end of the bogie
 - **FIL-TXEB** Chassis frame inner liner - From gearbox member to the end of the bogie
 - **BBOX-L** Battery box position - Left hand side
 - **2BAT210B** Battery Capacity - 2 x 210 Ah - Gel type
 - **2BAT210C** Battery Capacity - 2 x 210 Ah - AGM Absorbent Glass-fibre Material type
 - **2BATT170** Battery Capacity - 2 x 170 Ah on the left-hand side
 - **2BATT225** Battery Capacity - 2 x 225 Ah
 - **BATTAMP** Battery management - Voltage and current gauge
 - **BATTIND** Battery management - Charge indicator
 - **MSWI-C** Battery master switch - Chassis mounted toggle by the battery box
 - **MSWI-R** Battery master switch - Key fob operated remote controlled
 - **R315A56** Right fuel tank - 315litre aluminium diameter 560mm
Min volume 255l
Max volume 540l
 - **ADTP-BC** AdBlue tank position - Behind and under the cab on the right-hand side
 - **ADTP-L** AdBlue tank position - Chassis mounted on the left-hand side
 - **ADTP-R** AdBlue tank position - Chassis mounted on the right-hand side
 - **ADB048** Plastic AdBlue tank - 48 litre
 - **ADB050** Plastic AdBlue tank - 50 litre under/behind the cab
 - **ADB064** Plastic AdBlue tank - 64 litre
 - **ADB068** Plastic AdBlue tank - 68 litre
 - **ADB090** Plastic AdBlue tank - 90 litre
 - **FCAP-L** Diesel and AdBlue filler cap - Locking
 - **FUFF-AS** Fuel filler - Anti-spill device
 - **FUFF-ATS** Fuel filler - Anti-spill & anti-syphon device
 - **ESH-REAR** Exhaust - Horizontal silencer - rear outlet
 - **ESH-VERT** Exhaust - Horizontal silencer - vertical outlet
 - **EXST-SSP** Stainless steel exhaust stack - NOT polished
 - **EXST-ST** Steel exhaust stack
 - **WHC-FIX1** Wheel chock - One fixed design
 - **WHC-FIX2** Wheel chocks - Two fixed design
 - **WHC-FOL1** One foldable wheel chock
 - **WHC-FOL2** Two foldable wheel chocks
 - **WHCP-F** Wheel chock carrier position - In the front part of the vehicle
 - **WHCP-M** Wheel chock carrier position - Middle part of the vehicle
 - **WHCP-T** Wheel chock carrier position - Outer luggage locker
 - **CHAIN-S** Snow chains

■ Standard Equipment

□ Optional Equipment

For more detailed information about cab and powertrain equipment, please refer to separate specification sheets.

For all possible options and combinations of options please consult your Volvo sales contact who can create a specification to match your requirements using the Volvo Sales Support system (VSS).

The factory reserves the right to modify design and change equipment without previous notification. The specification can vary from country to country.

MODEL RANGE

NEW FMX13 4x4 Tractor - Rear Air Suspension - N3G FMX 44T 3A

- **TOWF-HD1** Front towing device - One heavy-duty front towing device
- **RFEC-B** Rear frame profile - Tapered
- **TOWR-ONE** Towing hitch attached to rear crossmember
- **TREL15** Trailer electrical connection - Single 15 pin - ADR certified
- **TREL7** 7 pole - 24N trailer electrical suzie
- **TREL7-7** Trailer electrical connection - 2 x 7 pin - 24N and 24S
- **TBC-EC** Trailer brakes with EC palm coupling connectors
- **TRBR-HCF** Full pressure hand controlled trailer brake
- **TRBR-STA** Stationary trailer brake control
- **TRB-STRE** Stretch Brake - Automatic low speed trailer brake activation to avoid jack-knifing and improve steerability
- **RFEND-B** Three piece EC approved rear mud wings and spray flaps
- **RFH-BAS** Basic rear wing height
- **RFH-HIG** High rear wing height - higher wing tops
- **RFH-LOW** Lower rear wing height - shallower wing tops
- **TL-LED** Rear lights - LED
- **BLIGHT-E** Emergency brake light
- WHEELS & TYRES**
- **RT-STEEL** Wheels - Steel rims
- **SPWT-D** Spare wheel & tyre with rear tyre pattern
- **SPWT-F** Spare wheel & tyre with front tyre pattern
- **SWCP-T** Spare wheel supplied temporarily strapped to chassis
- **SWCP-TP** Temporary spare wheel carrier on top of chassis frame
- **JACK-20T** 20 tonne bottle jack
- **TOOL-BAS** Basic Toolkit
- **TOOLKIT** Complete tool kit
- **INFLAHOS** Tyre inflation hose
- **GAUGE-TP** Tyre pressure gauge
- DRIVELINE EQUIPMENT**
- **TRAP-HD** Reinforced gearbox application
- **DRM-BE** Balanced & Economy Drive Mode
- **DRM-E** Economy Drive Mode
- **PVT-MAP** I-See Predictive Cruise Control - using map based topography information
- **CRUIS-E** Eco cruise control (with eco-roll and I-cruise, controls in steering wheel)
- **CRUIS-E5** Eco torque software - Improved economy mode. Fuel economy optimized cruise control for I-Save
- **CRUISEC** Cruise control, standard
- **AMSO-AUT** Enhanced I-shift software with manual shift available in auto mode and kickdown facility on accelerator pedal
- **AVO-ENH** I-Shift application software - for construction and off road applications
- **APF-ENH** I-shift enhanced PTO functions
- **RET-TPT** Hydraulic Retarder for Powertronic gearbox
- **TC-HWO** Transmission oil cooler - water to oil
- **TC-MAOH2** Extra high performance transmission oil cooler - air to oil with front mounted radiator
- **TC-MWO** Basic transmission oil cooler - water to oil
- **1COMP530** Air compressor - One-cylinder 530 litres per minute
- **2COM1100** Air compressor - Two-cylinder 1100 litres per minute
- **2COMP900** Air compressor - Two-cylinder 900 litres per minute
- **CLU-AIRC** Clutchable air compressor
- **AIRIN-HI** Air intake - Roof-mounted behind cab on the left-hand side
- **AIRIN-LO** Low level air intake behind cab on left hand side
- **ACL1ST-S** Air filter - two-stage element
- **24AL110B** Alternator capacity - 110 amp
- **24AL120B** Alternator capacity - 120 amp alternator
- **24AL150B** Alternator capacity - 150 amp
- **CCV-C** Closed crankcase engine ventilation
- **CCV-OX** Closed crankcase ventilation for cold markets
- **PRIM-EL** Electrical priming pump
- **PRIM-MAN** Manual priming pump
- **FUEQ-EH** Fuel line electric heater
- **AF-R** Hot fuel recirculation heated fuel filter
- **FUEFE2LW** Large engine mounted dual fuel filter with water separator
- **FUEFE2SW** Small engine mounted dual fuel filter with water separator
- **EST-AID** Engine starting aid -Preheating element in the air inlet manifold
- **220EBH15** 220V/1.5Kw electric engine block heater
- **PTER-100** Engine power-take-off - Rear-mounted with DIN100/ISO7646 flange
- **PTER-DIN** Engine power-take-off - Rear-mounted with DIN5462 (female) splined shaft for a close-coupled pump
Models with 3 steering axles will use this to drive the steering pump (AUXPSP)
- **PTER1400** Engine power-take-off - Rear-mounted with SAE 1410 flange
- **HPE-F101** Parker F1-101, engine mounted, fixed displacement, single flow, engine mounted hydraulic pump
- **HPE-F41** Parker F1-41, engine mounted, fixed displacement, single flow, engine mounted hydraulic pump
- **HPE-F51** Parker F1-51, engine mounted, fixed displacement, single flow, engine mounted hydraulic pump
- **HPE-F61** Parker F1-61, engine mounted, fixed displacement, single flow, engine mounted hydraulic pump
- **HPE-F81** Parker F1-81, engine mounted, fixed displacement, single flow, engine mounted hydraulic pump
- **HPE-T53** Parker F2-53/53, engine mounted, Fixed displacement, Twin flow engine mounted hydraulic pump
- **HPE-T70** Parker F2-70/35, engine mounted, Fixed displacement, Twin flow engine mounted hydraulic pump
- **HPE-V45** Parker VP1-45, variable displacement, single flow, engine mounted hydraulic pump
- **HPE-V75** Parker VP1-75, variable displacement, single flow, engine mounted hydraulic pump
- **PTPT-D** Powertronic PTO, 1 front/upper DIN connection for plug-in pump (max. 850 Nm)
- **PTPT-F** Powertronic PTO, 1 front/upper rear facing SAE flange conn. for prop shaft (max.850 Nm)
- **PTR-D** Gearbox PTO for plug-in pump, 0.71xeng speed
- **PTR-DH** Gearbox driven high speed PTO for one plug-in hydraulic pump
- **PTR-DM** Gearbox driven medium speed PTO for one plug-in hydraulic pump
- **PTR-F** Gearbox driven PTO with rear flange connection
- **PTRD-D** Gearbox driven HIGH SPEED PTO for two plug-in hydraulic pumps
- **PTRD-D1** PTRD-D1 Gearbox driven HIGH SPEED PTO (1 SAE flange & 1 plug-in hydraulic pump)
- **PTRD-D2** Gearbox driven HIGH SPEED PTO (2 SAE flanges & 1 plug-in hyd pump)
- **HPG-F101** Parker F1-101 gearbox mounted, fixed displacement, single flow, hydraulic pump
- **HPG-F41** Parker F1-41 gearbox mounted, fixed displacement, single flow, hydraulic pump
- **HPG-F51** Parker F1-51 gearbox mounted, fixed displacement, single flow, hydraulic pump
- **HPG-F61** Parker F1-61 gearbox mounted, fixed displacement, single flow, hydraulic pump
- **HPG-F81** Parker F1-81 gearbox mounted, fixed displacement, single flow, hydraulic pump
- **STWPOS-L** Steering wheel position - LEFT-HAND DRIVE
- **STWM-LE** Leather steering wheel
- **STGW-AD2** Adjustable steering wheel with neck tilt

■ Standard Equipment

□ Optional Equipment

For more detailed information about cab and powertrain equipment, please refer to separate specification sheets.

For all possible options and combinations of options please consult your Volvo sales contact who can create a specification to match your requirements using the Volvo Sales Support system (VSS).

The factory reserves the right to modify design and change equipment without previous notification. The specification can vary from country to country.

MODEL RANGE

NEW FMX13 4x4 Tractor - Rear Air Suspension - N3G FMX 44T 3A

<input checked="" type="checkbox"/> AIRBAG	SRS Driver's air bag	<input checked="" type="checkbox"/> PST-BAS1	Passenger seat - Fixed non suspended fold up with seatbelt mounted in cab
<input type="checkbox"/> INST-BAS	Basic level instruments	<input type="checkbox"/> PST-CF4	Passenger seat - Suspended, adjustable shock absorber, travel, backrest & lumbar controls - seatbelt mounted to the seat
<input checked="" type="checkbox"/> DRC-AM11	DPF Regeneration control switch - for manual and switching off regeneration	<input type="checkbox"/> PST-CF5	Passenger seat - Suspended with adjustable shock absorber, travel, backrest, lumbar & heat controls - seatbelt mounted to the seat
<input checked="" type="checkbox"/> 1DAYDIG2	Tachograph - Continental VDO 4.0	<input type="checkbox"/> SBPRE-PS	Passenger seat belt pretensioner
<input type="checkbox"/> ARSL	Additional road speed limit - switch in dashboard	<input type="checkbox"/> ARMRE-BB	Armrests - Two on both driver & passenger seats
<input type="checkbox"/> ESP-BAS1	Electronic Stability Control	<input type="checkbox"/> ARMRE-DB	Armrests - Two on the driver seat
<input type="checkbox"/> LSS-DW	Lane departure-warning system	<input type="checkbox"/> ARMRE-PB	Armrests - Two on the passenger seat
<input type="checkbox"/> DAS-W	Driver Alert Support system	<input type="checkbox"/> ARU-BAS	Armrest upholstery - Vinyl
<input type="checkbox"/> RSSENS-W	Rain sensing windscreen wipers	<input type="checkbox"/> ARU-LEA	Armrest upholstery - Leather
<input type="checkbox"/> CU-ECC	Cab Climate Unit - Electrically controlled air conditioning with sun sensor	<input checked="" type="checkbox"/> FMAT-RUB	Footwell floor mats - Rubber
<input type="checkbox"/> CU-ECC2	Cab Climate Unit - Electrically controlled air conditioning with a carbon filter, sun, mist, and air quality sensor	<input type="checkbox"/> FMAT-TX2	Footwell floor mats - Two sets, Rubber and textile with an embossed pile supplied in the cab
<input checked="" type="checkbox"/> CU-MCC	Cab Climate Unit - Manual air conditioning	<input checked="" type="checkbox"/> LBK70	Lower bunk 700 x2000 mm, fixed
<input checked="" type="checkbox"/> IMMOBIL	Thatcham H2 approved immobiliser	<input type="checkbox"/> MATL-FI	Firm lower bunk pocket sprung mattress
<input type="checkbox"/> ALARM-E	Enhanced vehicle alarm - Thatcham H1 approved - Cab plus external sensor for body/trailer	<input checked="" type="checkbox"/> MATL-SF	Lower flexizone mattress - semi-firm, pocket springs up to 100kg - 16 stone
<input type="checkbox"/> ALCOLOCK	Alcolock	<input type="checkbox"/> OLMAT-BA	35mm mattress overlay protector
<input type="checkbox"/> BUPMON	Back up monitor - Digital reverse camera, parameter & lead supplied loose in cab.	<input type="checkbox"/> OLMAT-PR	50mm premium mattress overlay protector
<input type="checkbox"/> PHONE-PK	Telephone preparation kit (antenna, antenna attachm. cable incl.)	<input type="checkbox"/> TBK60F	Fixed foldable top bunk 600 x 1900mm
<input type="checkbox"/> ISUNS-BS	Side sun visor - Driver & passenger side	<input type="checkbox"/> TBK70F	Fixed foldable top bunk 700 x 1900mm
<input checked="" type="checkbox"/> ISUNS-DS	Side sun visor - Driver-side	<input type="checkbox"/> PH-CAB2	1.8kW Air to air night heater
<input type="checkbox"/> ISUNF-B	Interior front sun visor without mirror	<input type="checkbox"/> PH-ENGCA	Engine and cab night heater
<input type="checkbox"/> ISUNF-MD	Interior front sun visor with mirror on driver side	<input type="checkbox"/> PH-SS	Short stop heater
<input type="checkbox"/> ISUNF-RE	Electrically operated textile interior sun blind	<input type="checkbox"/> SLCP-BAS	Sleeper control panel - Basic with switches for interior light, night heater, roof hatch and door lock
<input checked="" type="checkbox"/> ISUNF-RM	Manually operated textile interior sun blind	<input type="checkbox"/> ETSB-F	Storage on engine tunnel - Central document box with two rear cup holders
<input type="checkbox"/> ADFS	Two extra DIN slots in front shelf - can be fitted with card or drawer available as an accessory	<input type="checkbox"/> ETSB-FR	Storage on engine tunnel - Central document box with two rear cup holders & open storage pocket on cab rear wall
<input checked="" type="checkbox"/> BUPALARM	Reverse alarm	<input type="checkbox"/> ETSB-R	Storage on engine tunnel - Open storage pocket on cab rear wall
<input type="checkbox"/> RTOLL-PK	Road toll PREPARATION kit for trucks operating with "Toll Collect" in Germany	<input type="checkbox"/> RUS-BAS	Rear cab upper storage - 300 mm high
<input type="checkbox"/> LOADIND	Load indicator with central dashboard display	<input type="checkbox"/> RUS-HIG	Rear cab upper storage - 440 mm high - volume 245 litres
<input type="checkbox"/> REMC-MF	Multi-functio wireless remote control	<input type="checkbox"/> REF-ICPK	Fridge: engine tunnel mounted preparation kit
<input type="checkbox"/> FIREXT3S	Fire extinguisher - 3kg mounted on the seat base	<input type="checkbox"/> MICRO-PK	Wiring preparation kit for microwave oven
<input type="checkbox"/> WARNVEST	High visibility warning vest - no sleeves	<input type="checkbox"/> BOTH-D	One bottle holder under dashboard centre section
<input type="checkbox"/> AIDKIT	First aid kit - Legal demand for EU markets including delivery to EU bodybuilder	<input type="checkbox"/> COFMA-PK	Coffee maker, preparation kit.
<input type="checkbox"/> AIDKIT1B	First aid kit - Legal demand for trucks transiting Germany	<input checked="" type="checkbox"/> INLI-BAS	Interior white LED lights - basic
<input type="checkbox"/> WARNLAMP	Portable warning lamp	<input type="checkbox"/> INLI-NL	Interior white and red night LED light with no dimmer
<input type="checkbox"/> LAMP-IN	Inspection lamp	<input type="checkbox"/> INLI-NLD	Interior white and red night LED light with dimmer
<input type="checkbox"/> BULBKIT	Bulb and fuse kit	<input type="checkbox"/> ARL-FLEX	Two flexible reading lamps (snake lamps)
<input type="checkbox"/> WRITEPAD	Writing pad	<input checked="" type="checkbox"/> RH-EE	Fixed tinted glass sky window with emergency exit
<input checked="" type="checkbox"/> DST-CF4	Driver seat - Suspended, adjustable shock absorber, travel, backrest & lumbar controls - seatbelt mounted to the seat	<input type="checkbox"/> RH-ER	Steel roof hatch - Electrically operated, rear opening with emergency exit
<input type="checkbox"/> DST-CF5	Driver seat - Suspended with adjustable shock absorber, travel, backrest, lumbar & heat controls - seatbelt mounted to the seat	<input type="checkbox"/> RH-ETR	Tinted glass roof hatch - Electrically operated, rear opening with emergency exit
<input type="checkbox"/> DST-CF6	Driver seat - Suspended with adjustable shock absorber, travel, backrest, lumbar, heat and ventilation controls - seatbelt mounted to the seat	<input type="checkbox"/> RH-MTR	Tinted glass roof hatch - Manually operated, rear opening with emergency exit
<input type="checkbox"/> SBD-RED	Seat belt colour - Red	<input checked="" type="checkbox"/> GLAS-TIN	Tinted windows.
<input type="checkbox"/> SBPRE-DS	Driver seat belt pretensioner	<input type="checkbox"/> SWIND-BS	Extra side window on both sides behind "B" pillar
		<input type="checkbox"/> SWIND-PS	Cab side window - Left side rear behind 'B' post
		<input type="checkbox"/> AWIND-RF	Rear window
		<input type="checkbox"/> VANMIR	Vanity mirror in front shelf
		<input type="checkbox"/> AS-FUS	Extra shelf in front upper storage compartments

Standard Equipment

Optional Equipment

For more detailed information about cab and powertrain equipment, please refer to separate specification sheets.

For all possible options and combinations of options please consult your Volvo sales contact who can create a specification to match your requirements using the Volvo Sales Support system (VSS).

The factory reserves the right to modify design and change equipment without previous notification. The specification can vary from country to country.

MODEL RANGE

NEW FMX13 4x4 Tractor - Rear Air Suspension - N3G FMX 44T 3A

- INFOT-PK** Preparation kit for the mounting of a flat screen TV in cab above the driver's door, includes bracket, electrical and speaker connections

CAB EXTERIOR

- **EXTL-BAS** Basic exterior finish - Satin Volvo badges, grey grille, instep, bumper, bumper spoiler, grille, door handles mirror housing and sunvisor if specified.
- **DGLAS-H** Tempered door glass
- DGLAS-L** Laminated door glass
- **LOCK-CTL** Door locks - Central locking with key
- LOCK-REM** Door locks - Remote central locking
- **BUMP-HD** Heavy duty front bumper
- AUXFS** Lower swinging cab step
- GUARD-EH** Engine guard to protect sump and engine hoses
- **BUGNET** Insect screen in front of radiator
- CTILT-P-E** Electrically operated hydraulic cab tilt
- **CTILT-P-M** Manually operated hydraulic cab tilt
- FCABS-A** Front cab suspension - Air
- **FCABS-M** Front cab suspension - Mechanical spring
- RCABS-A** Rear cab suspension - Air
- **RCABS-M** Rear cab suspension - Mechanical spring
- MIRCFCPX** Mirrors - Electrically heated and operated - FMX- main and wide-angle with manually adjusted kerb view mirror on the passenger side and position camera in nearside mirror arm. To increase direct vision to the side the main mirrors have no cowlings
- MIRCOMFX** Electrically heated and operated -FMX- main and wide-angle mirrors with manually adjusted passenger kerb mirror, to increase direct vision to the side the main mirrors have no cowlings
- **MIRSTDX2** Electrically heated -FMX- main and wide-angle mirrors with manually adjusted passenger kerb mirror, to increase direct vision to the side the main mirrors have no cowlings
- **AMIR-F20** Auxiliary front view mirror with a 200mm radius
- SUNV-H** External smoke grey sunvisor
- AD-ROOF** Roof air deflector
- AD-SIDEL** Side air deflector extension panels
- AD-SIDES** Short cab side air deflector for rigid bodywork
- **HL-BASIC** Halogen H7 head lamps
- HL-CLEAN** Head lamp cleaner - washer jets
- HLP-ST** Headlamp protection
- HL-ADJ** Headlight adjustment - Switch in cab
- ASL-RF2** Two Hella H11 70W spotlamps in sign box - only available with the basic headlight and no lower driving lights.
- BEACOA2F** Roof beacons - Two front roof mounted amber LED
- BEACOA2R** Roof beacons - Two rear roof mounted amber LED
- BEACON-P** Roof beacons - wiring preparation only
- BEACONA4** Roof beacons - Four amber LED - two front/ two rear
- CABPT-R1** Single outlet for roof mounted accessories
- **CABPT-R2** Twin outlets for roof mounted accessories.
- SPOTP-F** Spotlamp preparation in front, max 280W
- SPOTP-R** Spotlamp preparation on roof, max 280W
- SPOTP-RF** Spotlamp preparation on cab roof and in cab front, max 2x280W
- ROS-IL2** Preparation kit for illuminated roof sign with switch loose in cab, fit after registration
- CSGN-FMX** "Volvo FMX" headboard logo
- **HORN-F1S** Horn - Air single tone - chassis mounted
- HORN-R2S** Horn - Air - Two roof-mounted

- ANT-CBR** Roof mounted antenna for CB radio, single aerial. Only Globetrotter cabs brings in extra DIN slots.

- ACCBR-AP** Front, middle & rear roof mounted accessory brackets
- ACCBR-F** Front roof mounted accessory bracket
- ACCBR-FM** Front & middle roof mounted accessory brackets
- ACCBR-FR** Front & rear roof mounted accessory brackets
- ACCBR-M** Middle roof mounted accessory bracket
- ACCBR-R** Rear roof mounted accessory bracket
- ACCBR-RM** Rear & middle roof mounted accessory brackets
- RFCAR-BC** Rear mudwing carrier, back of cab
- LADDER** Ladder back of cab
- REFS-TW** White cab conspicuity markings by packed in cab
- REFS-TY** Yellow cab conspicuity markings by packed in cab

SUPERSTRUCTURE PREPARATIONS

- **5WM-ISOM** Mount - 50mm L profiles with 10mm ISO plate - 60mm high above chassis frame
- 5WH150** Leg-height - 150 mm
- 5WH185** Leg-height - 185 mm
- 5WT-FO14** Fifth wheel - Fontaine 150SP2 pressed steel
- **5WT-JO10** Fifth wheel - Jost JSK 36 pressed
- 5WT-JO8** Fifth wheel - Jost JSK 37 cast
- 5WT-SH** Fifth wheel - SAF-Holland/+GF+ SK-S 36.20 cast
- 5WL-S1** Fifthwheel lubrication - locking mechanism and top plate
- 5WL-S2** Fifthwheel lubrication - locking mechanism
- TCIND** Trailer connection indicator - Sensors for height, kingpin and coupling lock
- **RDECK** Catwalk - Single plate and step
- RDECK-M** Catwalk - Extended with two plates and step
- SRWL-PK** Chassis-mounted working lamps - Side work and reverse lamp preparation and 3 position switch - Max load 280W
- SWL-2RA** Chassis-mounted working lamps - Two amber rear-mounted LED lamps
- SWL-2RW** Chassis-mounted working lamps - Two white rear-mounted LED lamps
- SWL-PK** Chassis-mounted working lamps - Side work lamp preparation and 2 position switch - Max load 280W
- **WL-TA1W** Coupling light - White
- WLC-H2A** Two H3/70W working lamps with amber coloured lens high mounted back of cab
- WLC-H2W** Two H3/70W white working lamps high mounted on the back of cab
- WLC-PKH** Preparation kit, cables and switch for high mounted working lamps back of cab
- WLC-PKL** Preparation kit, cables and switch for low mounted working lamps back of cab
- WLC-PKLH** Preparation kit - cables and switch for low and high mounted working lamps back of cab.
- **ECBB-BAS** Bodybuilder electrical centre without bodybuilder module
- ECBB-HIG** Body builder electrical centre with body builder module
- BBCHAS1** One 7-pole connector for Body builder interface
- BBCHAS3** Three 7-pole connectors for Body builder interface
- BEPR-T2** Body builder electrical software preparation for tipper with remote control
- TD-BAS** Trailer detection WITHOUT LED sensing
- **TD-LED** Trailer detection with LED sensing
- AUXL-SPK** Electrical preparation kit - wiring and switch for snow plough lights
- TAILPRE2** Tail lift preparation kit, wireless remote operation
- TAILPREP** Taillift preparation kit - cab switch and warning in driver display
- AESW2** Two Body builder bistable electrical switches (marked AUX1 / AUX2)
- AESW2PK** 2 Body builder bistable el.switches (marked AUX1/AUX2) and prep. for 4 more switches

■ Standard Equipment Optional Equipment

For more detailed information about cab and powertrain equipment, please refer to separate specification sheets.

For all possible options and combinations of options please consult your Volvo sales contact who can create a specification to match your requirements using the Volvo Sales Support system (VSS).

The factory reserves the right to modify design and change equipment without previous notification. The specification can vary from country to country.

MODEL RANGE

NEW FMX13 4x4 Tractor - Rear Air Suspension - N3G FMX 44T 3A

- **AUXSW-4** Wiring for 4 extra switches (from Body builder electrical centre to switch positions)

DELIVERY SERVICES

- **TGW-4GWL** Telematics gateway - GSM/GPRS/4G modem, LTE & WLAN
- **FMS-PK** Fleet Management System gateway
- **DRUT2** Driver utility app - "My Truck" - two-year subscription
For mobile phone, tablet, with android and IOS systems.
Only available with Volvo Connect subscription

VOLVO

Volvo Truck Corporation
volvotrucks.com