

# MODEL RANGE

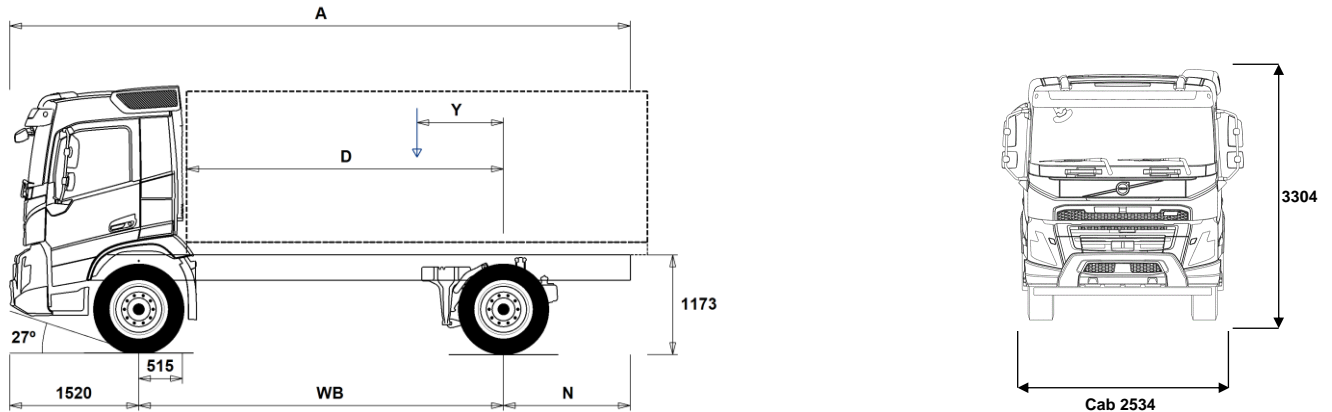

Volvo Trucks. Driving Progress

NEW FMX11 4x4 Rigid - Rear Air Suspension - N3G FMX 44R 1A



## Chassis Dimensions [mm]

WB Wheelbase	4000	4300	4600	4900
A Overall Chassis Length	7065	7365	7665	7965
D Center of rear axle to front of body	3435	3735	4035	4335
N Rear Overhang (Min.)	1395	1395	1395	1395
N Rear Overhang (Max.)	1545	1545	1545	1545
Y Center of Gravity for Payload (Min.)	563	598	635	672
Y Center of Gravity for Payload (Max.)	1114	1192	1272	1352

## Chassis Weights [kg]

Front Axle	5000	5020	5035	5045
Rear Axle	2100	2120	2130	2145
Kerb Weight	7100	7140	7165	7190
Payload (including body, driver, fuel, etc.)	10900	10860	10835	10810

## Turning Diameter [mm]

Turning Circle Diameter Kerb to Kerb	14300	15200	16100	17100
Turning Circle Diameter Wall to Wall	15800	16700	17600	18500

## Plated Weights [kg]

	Plated	Design
Gross Vehicle Weight	18000	21000
Gross Combination Weight	40000	40000
Front Axle	8000	8000
Rear Axle	11500	13000

## Important Notes

### Chassis Dimensions

Cab Height: +328 mm for CAB-HSLP, -262 mm for CAB-LDAY, -262 mm for CAB-LSLP, +16 mm for CAB-SLP.

Front Axle to Back of Cab: +431 mm for CAB-HSLP and CAB-SLP, -69 mm for CAB-LDAY, +425 mm for CAB-LSLP.

D-measure includes a front clearance of 50 mm and for rigid trucks also a subframe of 100 mm.

Height can vary  $\pm 20$  mm for leaf and  $\pm 10$  mm for air suspension.

All dimensions are for unladen chassis and any tag axles down.

Rear overhang used for vehicle weight calculation is the maximum rear overhang (N Max.) for selected wheelbase.

Weight and dimensions are based upon the following tyres:

Front Axle Tyres: 315/80R22.5  
Drive Axle Tyres: 315/80R22.5

**Chassis weight includes oil, water, AdBlue, 0 litres fuel and without driver. Kerb weight can vary  $\pm 3\%$ .**

Turning diameters are theoretically calculated.

Legal weights can differ from country to country.

For more detailed weight information, including optional equipment weights, ask your Volvo sales contact to enter your specification into the Volvo Weight Information system (WIS).

Do NOT use this drawing for bodybuilding. Refer to Volvo Bodybuilder Instructions and chassis assembly drawing FMX44R1A.

# MODEL RANGE

## NEW FMX11 4x4 Rigid - Rear Air Suspension - N3G FMX 44R 1A

### TRUCK USE

- **UNIFORM** Transport Adaption - Basic platform vehicle

### CORE COMPONENTS

- **RAD-G2** Rear air suspension, 1 axle - 1 driven, high ground clearance
  - **CDCOPREP**
  - **FMX-CREW** Cab - Fire four-door crew for up to 9 people
  - **FMX-DAY5** Cab - Day - with steel safety cage design  
Designed and built to Swedish impact and ECE R29 regulations
  - **FMX-HSL5** Cab - Globetrotter - with steel safety cage design  
Designed and built to Swedish impact and ECE R29 regulations
  - **FMX-LDA5** Cab - Low Day - with steel safety cage design  
Designed and built to Swedish impact and ECE R29 regulations
  - **FMX-LSL5** Cab - Low Sleeper - all-steel safety cage design.  
Built to Swedish impact and ECE R29 regulations
  - **FMX-SLP5** Cab - Sleeper - with steel safety cage design  
Designed and built to Swedish impact and ECE R29 regulations
  - **EU6SCR** Emission level - Euro VI step E
  - **D11K330** Engine - D11K330 10.8 litre engine developing 330hp at 16-1900rpm.  
Peak torque 1600Nm at 950-1400rpm.
  - **D11K380** Engine - D11K380 10.8 litre engine developing 380hp at 17-1900rpm.  
Peak torque 1800Nm at 950-1400rpm.
  - **D11K430** D11K430 10.8 litre engine developing 430hp at 17-1800rpm.  
Peak torque 2050Nm at 1058-1400rpm.
  - **D11K460** D11K460 10.8 litre engine developing 460hp at 16-1800rpm.  
Peak torque 2200Nm at 1050-1400rpm.
  - **EBR-EPG** Engine Brake Type - Exhaust brake controlled by steering column switch
  - **EBR-EPGC** Engine Brake Type - Exhaust pressure governor for I shift gearbox
  - **EBR-VEB** Engine Brake Type - Volvo engine brake and exhaust pressure governor retardation 300kW
  - **AT2612F** Gearbox - AT2612F 12-speed "I-shift" automated mechanical suitable for gross train weights up to 60tonne only.  
Refer to sales engineering when used in conjunction with a PTO
  - **ATO2612F** Gearbox - ATO2612F 12-speed "I-shift" overdrive automated mechanical, suitable for gross train weights up to 60tonne.  
Refer to sales engineering when used in conjunction with a PTO
  - **PT2106** Gearbox - Powertronic automatic 6-speed, max. engine torque 2100 Nm, max. permitted GCW 100000 kg
  - **RSH1370F** Drive Axle - RSH1370F 13-tonne hub reduction with differential lock - design GCW 70 tonne
- ### PACKAGES
- **DRIVE5** Drive Package
  - **DRIVE5+** Drive+ Package
  - **DRIVE5++** Drive++ Package
  - **1LIVINFM** Sleep & Resting Package - Living one-bed
  - **2LIVINFM** Sleep & Resting Package - Living two-bed
  - **INFOBAS** Basic media package without secondary display
  - **INFODF** Media Information Platform with Dynafleet Support
  - **INFOMED** Media Information Platform - Medium level
  - **INFONAV** Media Information Platform with Navigation
  - **INFONDF** Media Information Platform with Navigation & Dynafleet Support
- ### CHASSIS
- **FST-PAR3** Front suspension type - 3 leaf parabolic springs
  - **FAL10.0** Front axle design capacity - 10 tonne - check tyre capacity
  - **FAL8.0** Front axle design capacity - 8.0 tonne - check tyre capacity
  - **FAL9.0** Front axle design capacity - 9.0 tonne - check tyre capacity
  - **FSM-LUB** Front suspension maintenance - Lubricated rear shackles on pins and bushings
  - **FSTAB** Front anti-roll bar - Normal stiffness
  - **RAL13** Rear axle design capacity - 13 tonne
  - **RSTAB3** Rear anti-roll bar - Stiff
  - **ASF-DL1** Air suspension with 1 driving level
  - **ASF-DL3** Air suspension with 3 driving levels
  - **PSP-FIX** Power steering pump - Fixed displacement
  - **PSP-VAR** Power steering pump - Variable displacement
  - **EBS-MED** Brake package - EBS medium including "hill" hold function
  - **AUXPARK** Auxiliary parking brake - Additional spring brakes
  - **FRAME300** Chassis frame section external height - 300 mm
  - **FST8080** Chassis frame thickness - 8 mm web and flange
  - **FIL-EEEB** Chassis frame inner liner - From the end of the engine to the end of the bogie
  - **FIL-EEEF** Chassis frame inner liner - From the end of the engine to end of the frame
  - **FIL-TXEB** Chassis frame inner liner - From gearbox member to the end of the bogie
  - **FIL-TXEF** Chassis frame inner liner - From gearbox member to the end of the frame
  - **BBOX-L** Battery box position - Left hand side
  - **2BAT210B** Battery Capacity - 2 x 210 Ah - Gel type
  - **2BAT210C** Battery Capacity - 2 x 210 Ah - AGM Absorbent Glass-fibre Material type
  - **BATTAMP** Battery management - Voltage and current gauge
  - **BATTIND** Battery management - Charge indicator
  - **MSWI-C** Battery master switch - Chassis mounted toggle by the battery box
  - **MSWI-R** Battery master switch - Key fob operated remote controlled
  - **R315A56** Right fuel tank - 315litre aluminium diameter 560mm  
Min volume 255l  
Max volume 630l
  - **ADTP-L** AdBlue tank position - Chassis mounted on the left-hand side
  - **ADTP-R** AdBlue tank position - Chassis mounted on the right-hand side
  - **ADB048** Plastic AdBlue tank - 48 litre
  - **ADB064** Plastic AdBlue tank - 64 litre
  - **ADB068** Plastic AdBlue tank - 68 litre
  - **ADB090** Plastic AdBlue tank - 90 litre
  - **FCAP-L** Diesel and AdBlue filler cap - Locking
  - **FUFF-AS** Fuel filler - Anti-spill device
  - **FUFF-ATS** Fuel filler - Anti-spill & anti-syphon device
  - **ESH-REAR** Exhaust - Horizontal silencer - rear outlet
  - **ESH-VERT** Exhaust - Horizontal silencer - vertical outlet
  - **EXST-SSP** Stainless steel exhaust stack - NOT polished
  - **EXST-ST** Steel exhaust stack
  - **WHC-FIX1** Wheel chock - One fixed design
  - **WHC-FIX2** Wheel chocks - Two fixed design
  - **WHC-FOL1** One foldable wheel chock
  - **WHC-FOL2** Two foldable wheel chocks
  - **WHCP-F** Wheel chock carrier position - In the front part of the vehicle
  - **WHCP-M** Wheel chock carrier position - Middle part of the vehicle
  - **WHCP-R** Wheel chock carrier position - In the rear part of the vehicle
  - **WHCP-T** Wheel chock carrier position - Outer luggage locker
  - **CHAIN-S** Snow chains
  - **HOOK-SC** Snow chain hooks
  - **TOWF-HD1** Front towing device - One heavy-duty front towing device
  - **TOWMBRH** Towing member, high mounted in centre of frame, D = 190
  - **TOWMBRL1** Towing member, low mounted under the frame

■ Standard Equipment

□ Optional Equipment

For more detailed information about cab and powertrain equipment, please refer to separate specification sheets.

For all possible options and combinations of options please consult your Volvo sales contact who can create a specification to match your requirements using the Volvo Sales Support system (VSS).

The factory reserves the right to modify design and change equipment without previous notification. The specification can vary from country to country.

# MODEL RANGE

## NEW FMX11 4x4 Rigid - Rear Air Suspension - N3G FMX 44R 1A

- TOWMBRM** Towing member, medium mounted in line with frame lower flange
  - RFEC-S** Rear frame profile - Straight cut
  - RFEC-U** Rear frame profile - Slight uppercut for tipppers
  - C-RI4040** Towing coupling, Ringfeder 4040 G-150
  - C-RI5055** Towing coupling, Ringfeder 5055 G-150
  - C-RO400G** Towing coupling, Rockinger 400 G-150 for 40mm eyes
  - C-RO50** Rockinger RO 50 50mm for centre axle trailer
  - TOWR-ONE** Towing hitch attached to rear crossmember
  - TREL-PK** Trailer electrical preparation kit - chassis/cab wiring
  - TREL14** Single 14 pole electrical trailer connector
  - TREL15** Trailer electrical connection - Single 15 pin - ADR certified
  - TREL7** 7 pole - 24N trailer electrical suzie
  - TREL7-7** Trailer electrical connection - 2 x 7 pin - 24N and 24S
  - TBC-DUO** Duomatic type air line connectors
  - TBC-EC** Trailer brakes with EC palm coupling connectors
  - TRBR-HCF** Full pressure hand controlled trailer brake
  - TRBR-STA** Stationary trailer brake control
  - TRB-STRE** Stretch Brake - Automatic low speed trailer brake activation to avoid jack-knifing and improve steerability
  - RFEND-B** Three piece EC approved rear mud wings and spray flaps
  - RFEND-T** Rear mud wings - Temporary on drive axle for transport delivery only
  - RFH-BAS** Basic rear wing height
  - RFH-HIG** High rear wing height - higher wing tops
  - RFH-LOW** Lower rear wing height - shallower wing tops
  - TL-LED** Rear lights - LED
  - BLIGHT-E** Emergency brake light
- ### WHEELS & TYRES
- RT-STEEL** Wheels - Steel rims
  - SPWT-D** Spare wheel & tyre with rear tyre pattern
  - SPWT-F** Spare wheel & tyre with front tyre pattern
  - SWCP-R** Rear mounted spare wheel carrier
  - SWCP-T** Spare wheel supplied temporarily strapped to chassis
  - SWCP-TP** Temporary spare wheel carrier on top of chassis frame
  - JACK-20T** 20 tonne bottle jack
  - TOOL-BAS** Basic Toolkit
  - TOOLKIT** Complete tool kit
  - INFLAHOS** Tyre inflation hose
  - GAUGE-TP** Tyre pressure gauge
- ### DRIVELINE EQUIPMENT
- TRAP-HD** Reinforced gearbox application
  - DRM-BE** Balanced & Economy Drive Mode
  - DRM-E** Economy Drive Mode
  - PVT-MAP** I-See Predictive Cruise Control - using map based topography information
  - CRUIS-E** Eco cruise control (with eco-roll and I-cruise, controls in steering wheel)
  - CRUIS-E5** Eco torque software - Improved economy mode. Fuel economy optimized cruise control for I-Save
  - CRUISEC** Cruise control, standard
  - AMSO-AUT** Enhanced I-shift software with manual shift available in auto mode and kickdown facility on accelerator pedal
  - AVO-ENH** I-Shift application software - for construction and off road applications
  - APF-ENH** I-shift enhanced PTO functions
  - RET-TPT** Hydraulic Retarder for Powertronic gearbox
  - TC-HWO** Transmission oil cooler - water to oil
  - TC-MAOH2** Extra high performance transmission oil cooler - air to oil with front mounted radiator
  - TC-MWO** Basic transmission oil cooler - water to oil
  - 1COMP530** Air compressor - One-cylinder 530 litres per minute
  - 2COM1100** Air compressor - Two-cylinder 1100 litres per minute
  - 2COMP900** Air compressor - Two-cylinder 900 litres per minute
  - CLU-AIRC** Clutchable air compressor
  - AIRIN-HI** Air intake - Roof-mounted behind cab on the left-hand side
  - AIRIN-LO** Low level air intake behind cab on left hand side
  - ACL1ST-S** Air filter - two-stage element
  - 24AL110B** Alternator capacity - 110 amp
  - 24AL120B** Alternator capacity - 120 amp alternator
  - 24AL150B** Alternator capacity - 150 amp
  - CCV-C** Closed crankcase engine ventilation
  - CCV-OX** Closed crankcase ventilation for cold markets
  - PRIM-EL** Electrical priming pump
  - PRIM-MAN** Manual priming pump
  - FUEQ-EH** Fuel line electric heater
  - AF-R** Hot fuel recirculation heated fuel filter
  - FUEFE2SW** Small engine mounted dual fuel filter with water separator
  - EST-AID** Engine starting aid -Preheating element in the air inlet manifold
  - 220EBH15** 220V/1.5Kw electric engine block heater
  - PTER-100** Engine power-take-off - Rear-mounted with DIN100/ISO7646 flange
  - PTER-DIN** Engine power-take-off - Rear-mounted with DIN5462 (female) splined shaft for a close-coupled pump  
Models with 3 steering axles will use this to drive the steering pump (AUXPSP)
  - PTER1400** Engine power-take-off - Rear-mounted with SAE 1410 flange
  - HPE-F101** Parker F1-101, engine mounted, fixed displacement, single flow, engine mounted hydraulic pump
  - HPE-F41** Parker F1-41, engine mounted, fixed displacement, single flow, engine mounted hydraulic pump
  - HPE-F51** Parker F1-51, engine mounted, fixed displacement, single flow, engine mounted hydraulic pump
  - HPE-F61** Parker F1-61, engine mounted, fixed displacement, single flow, engine mounted hydraulic pump
  - HPE-F81** Parker F1-81, engine mounted, fixed displacement, single flow, engine mounted hydraulic pump
  - HPE-T53** Parker F2-53/53, engine mounted, Fixed displacement, Twin flow engine mounted hydraulic pump
  - HPE-T70** Parker F2-70/35, engine mounted, Fixed displacement, Twin flow engine mounted hydraulic pump
  - HPE-V45** Parker VP1-45, variable displacement, single flow, engine mounted hydraulic pump
  - HPE-V75** Parker VP1-75, variable displacement, single flow, engine mounted hydraulic pump
  - PTPT-D** Powertronic PTO, 1 front/upper DIN connection for plug-in pump (max. 850 Nm)
  - PTPT-F** Powertronic PTO, 1 front/upper rear facing SAE flange conn. for prop shaft (max.850 Nm)
  - PTR-D** Gearbox PTO for plug-in pump, 0.71xeng speed
  - PTR-DH** Gearbox driven high speed PTO for one plug-in hydraulic pump
  - PTR-DM** Gearbox driven medium speed PTO for one plug-in hydraulic pump
  - PTR-F** Gearbox driven PTO with rear flange connection
  - PTRD-D** Gearbox driven HIGH SPEED PTO for two plug-in hydraulic pumps
  - PTRD-D1** PTRD-D1 Gearbox driven HIGH SPEED PTO (1 SAE flange & 1 plug-in hydraulic pump)
  - PTRD-D2** Gearbox driven HIGH SPEED PTO (2 SAE flanges & 1 plug-in hyd pump)
  - HPG-F101** Parker F1-101 gearbox mounted, fixed displacement, single flow, hydraulic pump

Standard Equipment

Optional Equipment

For more detailed information about cab and powertrain equipment, please refer to separate specification sheets.

For all possible options and combinations of options please consult your Volvo sales contact who can create a specification to match your requirements using the Volvo Sales Support system (VSS).

The factory reserves the right to modify design and change equipment without previous notification. The specification can vary from country to country.

# MODEL RANGE

## NEW FMX11 4x4 Rigid - Rear Air Suspension - N3G FMX 44R 1A

- |   |  |
|---|--|
| <ul style="list-style-type: none"> <li><input type="checkbox"/> <b>HPG-F41</b> Parker F1-41 gearbox mounted, fixed displacement, single flow, hydraulic pump</li> <li><input type="checkbox"/> <b>HPG-F51</b> Parker F1-51 gearbox mounted, fixed displacement, single flow, hydraulic pump</li> <li><input type="checkbox"/> <b>HPG-F61</b> Parker F1-61 gearbox mounted, fixed displacement, single flow, hydraulic pump</li> <li><input type="checkbox"/> <b>HPG-F81</b> Parker F1-81 gearbox mounted, fixed displacement, single flow, hydraulic pump</li> <li>■ <b>STWPOS-R</b> Steering wheel position - RIGHT-HAND DRIVE</li> <li><input type="checkbox"/> <b>STWM-LE</b> Leather steering wheel</li> <li><input type="checkbox"/> <b>STGW-AD2</b> Adjustable steering wheel with neck tilt</li> <li>■ <b>STGW-ADJ</b> Adjustable steering wheel</li> <li>■ <b>AIRBAG</b> SRS Driver's air bag</li> <li><input type="checkbox"/> <b>INST-BAS</b> Basic level instruments</li> <li>■ <b>DRC-AMII</b> DPF Regeneration control switch - for manual and switching off regeneration</li> <li>■ <b>1DAYDIG2</b> Tachograph - Continental VDO 4.0</li> <li><input type="checkbox"/> <b>ARSL</b> Additional road speed limit - switch in dashboard</li> <li><input type="checkbox"/> <b>ESP-BAS1</b> Electronic Stability Control</li> <li><input type="checkbox"/> <b>LSS-DW</b> Lane departure-warning system</li> <li><input type="checkbox"/> <b>DAS-W</b> Driver Alert Support system</li> <li><input type="checkbox"/> <b>RSENS-W</b> Rain sensing windscreen wipers</li> <li><input type="checkbox"/> <b>CU-ECC</b> Cab Climate Unit - Electrically controlled air conditioning with sun sensor</li> <li><input type="checkbox"/> <b>CU-ECC2</b> Cab Climate Unit - Electrically controlled air conditioning with a carbon filter, sun, mist, and air quality sensor</li> <li>■ <b>CU-MCC</b> Cab Climate Unit - Manual air conditioning</li> <li>■ <b>IMMOBIL</b> Thatcham H2 approved immobiliser</li> <li><input type="checkbox"/> <b>ALARM-E</b> Enhanced vehicle alarm - Thatcham H1 approved - Cab plus external sensor for body/trailer</li> <li><input type="checkbox"/> <b>ALCOLOCK</b> Alcolock</li> <li><input type="checkbox"/> <b>BUPMON</b> Back up monitor - Digital reverse camera, parameter &amp; lead supplied loose in cab.</li> <li><input type="checkbox"/> <b>PHONE-PK</b> Telephone preparation kit (antenna, antenna attachm. cable incl.)</li> <li><input type="checkbox"/> <b>ISUNS-BS</b> Side sun visor - Driver &amp; passenger side</li> <li>■ <b>ISUNS-DS</b> Side sun visor - Driver-side</li> <li><input type="checkbox"/> <b>ISUNF-B</b> Interior front sun visor without mirror</li> <li><input type="checkbox"/> <b>ISUNF-MD</b> Interior front sun visor with mirror on driver side</li> <li><input type="checkbox"/> <b>ISUNF-RE</b> Electrically operated textile interior sun blind</li> <li>■ <b>ISUNF-RM</b> Manually operated textile interior sun blind</li> <li><input type="checkbox"/> <b>ADFS</b> Two extra DIN slots in front shelf - can be fitted with card or drawer available as an accessory</li> <li>■ <b>BUPALARM</b> Reverse alarm</li> <li><input type="checkbox"/> <b>RTOLL-PK</b> Road toll PREPARATION kit for trucks operating with "Toll Collect" in Germany</li> <li><input type="checkbox"/> <b>LOADIND</b> Load indicator with central dashboard display</li> <li><input type="checkbox"/> <b>REMC-MF</b> Multi-functio wireless remote control</li> <li><input type="checkbox"/> <b>FIREXT3S</b> Fire extinguisher - 3kg mounted on the seat base</li> <li><input type="checkbox"/> <b>WARNVEST</b> High visibility warning vest - no sleeves</li> <li><input type="checkbox"/> <b>AIDKIT</b> First aid kit - Legal demand for EU markets including delivery to EU bodybuilder</li> <li><input type="checkbox"/> <b>AIDKIT1B</b> First aid kit - Legal demand for trucks transiting Germany</li> <li><input type="checkbox"/> <b>WARNLAMP</b> Portable warning lamp</li> <li><input type="checkbox"/> <b>LAMP-IN</b> Inspection lamp</li> <li><input type="checkbox"/> <b>BULBKIT</b> Bulb and fuse kit</li> </ul> | <ul style="list-style-type: none"> <li><input type="checkbox"/> <b>WRITEPAD</b> Writing pad</li> <li>■ <b>DST-CF4</b> Driver seat - Suspended, adjustable shock absorber, travel, backrest &amp; lumbar controls - seatbelt mounted to the seat</li> <li><input type="checkbox"/> <b>DST-CF5</b> Driver seat - Suspended with adjustable shock absorber, travel, backrest, lumbar &amp; heat controls - seatbelt mounted to the seat</li> <li><input type="checkbox"/> <b>DST-CF6</b> Driver seat - Suspended with adjustable shock absorber, travel, backrest, lumbar, heat and ventilation controls - seatbelt mounted to the seat</li> <li><input type="checkbox"/> <b>SBD-RED</b> Seat belt colour - Red</li> <li><input type="checkbox"/> <b>SBPRE-DS</b> Driver seat belt pretensioner</li> <li>■ <b>PST-BAS1</b> Passenger seat - Fixed non suspended fold up with seatbelt mounted in cab</li> <li><input type="checkbox"/> <b>PST-CF4</b> Passenger seat - Suspended, adjustable shock absorber, travel, backrest &amp; lumbar controls - seatbelt mounted to the seat</li> <li><input type="checkbox"/> <b>PST-CF5</b> Passenger seat - Suspended with adjustable shock absorber, travel, backrest, lumbar &amp; heat controls - seatbelt mounted to the seat</li> <li><input type="checkbox"/> <b>PST-STD2</b> Passenger seat - Fixed with backrest adjustment, non suspended with seatbelt mounted in cab</li> <li><input type="checkbox"/> <b>PST-STD4</b> Passenger seat - Standard suspended with seatbelt mounted in cab</li> <li><input type="checkbox"/> <b>SBPRE-PS</b> Passenger seat belt pretensioner</li> <li><input type="checkbox"/> <b>ARMRE-BB</b> Armrests - Two on both driver &amp; passenger seats</li> <li><input type="checkbox"/> <b>ARMRE-DB</b> Armrests - Two on the driver seat</li> <li><input type="checkbox"/> <b>ARMRE-PB</b> Armrests - Two on the passenger seat</li> <li><input type="checkbox"/> <b>ARU-BAS</b> Armrest upholstery - Vinyl</li> <li><input type="checkbox"/> <b>ARU-LEA</b> Armrest upholstery - Leather</li> <li>■ <b>FMAT-RUB</b> Footwell floor mats - Rubber</li> <li><input type="checkbox"/> <b>FMAT-TX2</b> Footwell floor mats - Two sets, Rubber and textile with an embossed pile supplied in the cab</li> <li><input type="checkbox"/> <b>LBK70</b> Lower bunk 700 x2000 mm, fixed</li> <li><input type="checkbox"/> <b>MATL-FI</b> Firm lower bunk pocket sprung mattress</li> <li><input type="checkbox"/> <b>MATL-SF</b> Lower flexizone mattress - semi-firm, pocket springs up to 100kg - 16 stone</li> <li><input type="checkbox"/> <b>OLMAT-BA</b> 35mm mattress overlay protector</li> <li><input type="checkbox"/> <b>OLMAT-PR</b> 50mm premium mattress overlay protector</li> <li><input type="checkbox"/> <b>TBK60F</b> Fixed foldable top bunk 600 x 1900mm</li> <li><input type="checkbox"/> <b>TBK70F</b> Fixed foldable top bunk 700 x 1900mm</li> <li><input type="checkbox"/> <b>PH-CAB2</b> 1.8kW Air to air night heater</li> <li><input type="checkbox"/> <b>PH-ENGCA</b> Engine and cab night heater</li> <li><input type="checkbox"/> <b>PH-SS</b> Short stop heater</li> <li><input type="checkbox"/> <b>SLCP-BAS</b> Sleeper control panel - Basic with switches for interior light, night heater, roof hatch and door lock</li> <li><input type="checkbox"/> <b>ETSB-F</b> Storage on engine tunnel - Central document box with two rear cup holders</li> <li><input type="checkbox"/> <b>ETSB-FR</b> Storage on engine tunnel - Central document box with two rear cup holders &amp; open storage pocket on cab rear wall</li> <li><input type="checkbox"/> <b>ETSB-R</b> Storage on engine tunnel - Open storage pocket on cab rear wall</li> <li><input type="checkbox"/> <b>RUS-BAS</b> Rear cab upper storage - 300 mm high</li> <li><input type="checkbox"/> <b>RUS-HIG</b> Rear cab upper storage - 440 mm high - volume 245 litres</li> <li><input type="checkbox"/> <b>REF-ICPK</b> Fridge: engine tunnel mounted preparation kit</li> <li><input type="checkbox"/> <b>MICRO-PK</b> Wiring preparation kit for microwave oven</li> <li><input type="checkbox"/> <b>BOTH-D</b> One bottle holder under dashboard centre section</li> <li><input type="checkbox"/> <b>COFMA-PK</b> Coffee maker, preparation kit.</li> <li>■ <b>INLI-BAS</b> Interior white LED lights - basic</li> <li><input type="checkbox"/> <b>INLI-NL</b> Interior white and red night LED light with no dimmer</li> <li><input type="checkbox"/> <b>INLI-NLD</b> Interior white and red night LED light with dimmer</li> <li><input type="checkbox"/> <b>ARL-FLEX</b> Two flexible reading lamps (snake lamps)</li> <li>■ <b>RH-EE</b> Fixed tinted glass sky window with emergency exit</li> </ul> |
|---|--|

■ Standard Equipment

Optional Equipment

For more detailed information about cab and powertrain equipment, please refer to separate specification sheets.

For all possible options and combinations of options please consult your Volvo sales contact who can create a specification to match your requirements using the Volvo Sales Support system (VSS).

The factory reserves the right to modify design and change equipment without previous notification. The specification can vary from country to country.

# MODEL RANGE

## NEW FMX11 4x4 Rigid - Rear Air Suspension - N3G FMX 44R 1A

- RH-ER** Steel roof hatch - Electrically operated, rear opening with emergency exit
  - RH-ETR** Tinted glass roof hatch - Electrically operated, rear opening with emergency exit
  - RH-MTR** Tinted glass roof hatch - Manually operated, rear opening with emergency exit
  - GLAS-TIN** Tinted windows.
  - SWIND-BS** Extra side window on both sides behind "B" pillar
  - SWIND-PS** Cab side window - Left side rear behind 'B' post
  - AWIND-RF** Rear window
  - VANMIR** Vanity mirror in front shelf
  - AS-FUS** Extra shelf in front upper storage compartments
  - INFOT-PK** Preparation kit for the mounting of a flat screen TV in cab above the driver's door, includes bracket, electrical and speaker connections
- ### CAB EXTERIOR
- EXTL-BAS** Basic exterior finish - Satin Volvo badges, grey grille, instep, bumper, bumper spoiler, grille, door handles mirror housing and sunvisor if specified.
  - DGLAS-H** Tempered door glass
  - DGLAS-L** Laminated door glass
  - LOCK-CTL** Door locks - Central locking with key
  - LOCK-REM** Door locks - Remote central locking
  - BUMP-HD** Heavy duty front bumper
  - AUXFS** Lower swinging cab step
  - GUARD-EH** Engine guard to protect sump and engine hoses
  - BUGNET** Insect screen in front of radiator
  - CTILT-P-E** Electrically operated hydraulic cab tilt
  - CTILT-P-M** Manually operated hydraulic cab tilt
  - FCABS-A** Front cab suspension - Air
  - FCABS-M** Front cab suspension - Mechanical spring
  - RCABS-A** Rear cab suspension - Air
  - RCABS-M** Rear cab suspension - Mechanical spring
  - MIRFCPX** Mirrors - Electrically heated and operated - FMX- main and wide-angle with manually adjusted kerb view mirror on the passenger side and position camera in nearside mirror arm. To increase direct vision to the side the main mirrors have no cowlings
  - MIRCOMFX** Electrically heated and operated -FMX- main and wide-angle mirrors with manually adjusted passenger kerb mirror, to increase direct vision to the side the main mirrors have no cowlings
  - MIRSTDX2** Electrically heated -FMX- main and wide-angle mirrors with manually adjusted passenger kerb mirror, to increase direct vision to the side the main mirrors have no cowlings
  - AMIR-F20** Auxiliary front view mirror with a 200mm radius
  - SUNV-H** External smoke grey sunvisor
  - AD-ROOF** Roof air deflector
  - AD-SIDES** Short cab side air deflector for rigid bodywork
  - HL-BASIC** Halogen H7 head lamps
  - HL-CLEAN** Head lamp cleaner - washer jets
  - HLP-ST** Headlamp protection
  - HL-ADJ** Headlight adjustment - Switch in cab
  - ASL-RF2** Two Hella H11 70W spotlamps in sign box - only available with the basic headlight and no lower driving lights.
  - BEACOA2F** Roof beacons - Two front roof mounted amber LED
  - BEACOA2R** Roof beacons - Two rear roof mounted amber LED
  - BEACON-P** Roof beacons - wiring preparation only
  - BEACONA4** Roof beacons - Four amber LED - two front/ two rear
- CABPT-R1** Single outlet for roof mounted accessories
  - CABPT-R2** Twin outlets for roof mounted accessories.
  - SPOTP-F** Spotlamp preparation in front, max 280W
  - SPOTP-R** Spotlamp preparation on roof, max 280W
  - SPOTP-RF** Spotlamp preparation on cab roof and in cab front, max 2x280W
  - ROS-IL2** Preparation kit for illuminated roof sign with switch loose in cab, fit after registration
  - CSGN-FMX** "Volvo FMX" headboard logo
  - HORN-F1S** Horn - Air single tone - chassis mounted
  - HORN-R2S** Horn - Air - Two roof-mounted
  - ANT-CBR** Roof mounted antenna for CB radio, single aerial. Only Globetrotter cabs brings in extra DIN slots.
  - ACCB-AP** Front, middle & rear roof mounted accessory brackets
  - ACCB-F** Front roof mounted accessory bracket
  - ACCB-FM** Front & middle roof mounted accessory brackets
  - ACCB-FR** Front & rear roof mounted accessory brackets
  - ACCB-M** Middle roof mounted accessory bracket
  - ACCB-R** Rear roof mounted accessory bracket
  - ACCB-RM** Rear & middle roof mounted accessory brackets
  - REFS-TW** White cab conspicuity markings by packed in cab
  - REFS-TY** Yellow cab conspicuity markings by packed in cab
- ### SUPERSTRUCTURE PREPARATIONS
- SRWL-PK** Chassis-mounted working lamps - Side work and reverse lamp preparation and 3 position switch - Max load 280W
  - SWL-2FW** Chassis-mounted working lamps - Two white front-mounted LED lamps
  - SWL-2RW** Chassis-mounted working lamps - Two white rear-mounted LED lamps
  - SWL-4W** Chassis-mounted working lamps - Four white front and rear-mounted LED lamps
  - SWL-PK** Chassis-mounted working lamps - Side work lamp preparation and 2 position switch - Max load 280W
  - WLC-H2A** Two H3/70W working lamps with amber coloured lens high mounted back of cab
  - WLC-H2W** Two H3/70W white working lamps high mounted on the back of cab
  - WLC-PKCH** Working lamp back of cab - Preparation kit - cables and switch
  - WLC-PKH** Preparation kit, cables and switch for high mounted working lamps back of cab
  - WLC-PKL** Preparation kit, cables and switch for low mounted working lamps back of cab
  - WLC-PKLH** Preparation kit - cables and switch for low and high mounted working lamps back of cab.
  - ECBB-HIG** Body builder electrical centre with body builder module
  - BBCHAS1** One 7-pole connector for Body builder interface
  - BBCHAS3** Three 7-pole connectors for Body builder interface
  - BEPR-T2** Body builder electrical software preparation for tipper with remote control
  - TD-BAS** Trailer detection WITHOUT LED sensing
  - TD-LED** Trailer detection with LED sensing
  - FRFS-BS** Frame rail free space on both sides to give space for crane legs or other equipment.
  - FBA-BTF** Lower front body attachments for torsionally flexible - platform body
  - FBA-BTSF** Lower front body attachments for torsionally semi-flexible body - box or curtainsider
  - HBA-FSFB** Holes for body attachments - flexible/semi-flexible body
  - HBA-SB** Holes for body attachments - stiff body
  - RBA-T2** Lower rear body attachments for helper frame
  - AUXL-SPK** Electrical preparation kit - wiring and switch for snow plough lights
  - TAILPRE2** Tail lift preparation kit, wireless remote operation

Standard Equipment

Optional Equipment

For more detailed information about cab and powertrain equipment, please refer to separate specification sheets.

For all possible options and combinations of options please consult your Volvo sales contact who can create a specification to match your requirements using the Volvo Sales Support system (VSS).

The factory reserves the right to modify design and change equipment without previous notification. The specification can vary from country to country.

# MODEL RANGE

## NEW FMX11 4x4 Rigid - Rear Air Suspension - N3G FMX 44R 1A

---

- **TAILPREP** Taillift preparation kit - cab switch and warning in driver display
- **AESW2** Two Body builder bistable electrical switches (marked AUX1 / AUX2)
- **AESW2PK** 2 Body builder bistable el.switches (marked AUX1/AUX2) and prep. for 4 more switches
- **AUXSW-4** Wiring for 4 extra switches (from Body builder electrical centre to switch positions)

### DELIVERY SERVICES

- **TGW-4GWL** Telematics gateway - GSM/GPRS/4G modem, LTE & WLAN
- **FMS-PK** Fleet Management System gateway
- **DRUT2** Driver utility app - "My Truck" - two-year subscription  
For mobile phone, tablet, with android and IOS systems.  
Only available with Volvo Connect subscription

**VOLVO**

Volvo Truck Corporation  
volvotrucks.com