

# MODEL RANGE

NEW FM Low Entry Battery Electric 8x2 Pusher & Tag Rigid - Full Air Suspension

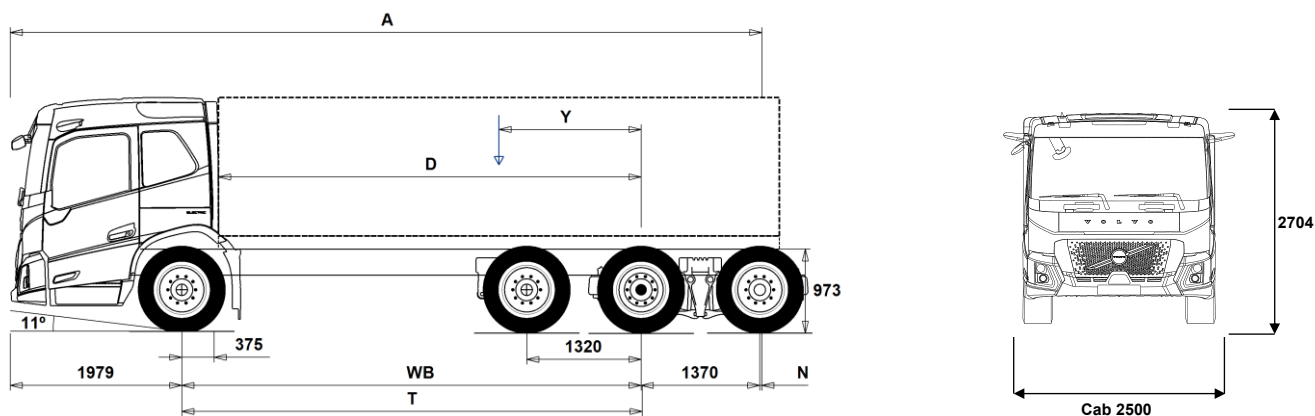

## Chassis Dimensions [mm]

WB Wheelbase	5300	5600
A Overall Chassis Length	11024	11324
D Center of rear axle to front of body	4875	5175
N Rear Overhang	2375	2375
T Theoretical Wheelbase	5314	5614
Y Center of Gravity for Payload (Min.)	269	266
Y Center of Gravity for Payload (Max.)	269	266

## Chassis Weights [kg]

Front Axle	6405	6475
Rear Bogie	4555	4505
Kerb Weight	10960	10980
Payload (including body, driver, fuel, etc.)	20540	20520

## Turning Diameter [mm]

Turning Circle Diameter Kerb to Kerb	20800	21700
Turning Circle Diameter Wall to Wall	22800	23700

## Plated Weights [kg]

	Plated	Design
Gross Vehicle Weight	31500	35000
Gross Combination Weight	32000	32000
Front Axle	7500	8000
Rear Bogie	24000	27000

## Important Notes

### Chassis Dimensions

Cab Height: +374 mm for CAB-HCR2.  
 D-measure includes a front clearance of 50 mm and for rigid trucks also a subframe of 100 mm.  
 Height can vary ± 20 mm for leaf and ± 10 mm for air suspension.  
 All dimensions are for unladen chassis and any tag axles down.

Weight and dimensions are based upon the following tyres:

Front Axle Tyres:	315/70R22.5
Drive Axle Tyres:	315/70R22.5
Trailing/Pusher Axle Tyres:	315/70R22.5

Chassis weight includes oil, water, AdBlue, 0 litres fuel and without driver. Kerb weight can vary ± 3%.

Turning diameters are theoretically calculated. Tag axle used: TA-FIXED.

Legal weights can differ from country to country.

For more detailed weight information, including optional equipment weights, ask your Volvo sales contact to enter your specification into the Volvo Weight Information system (WIS).

Do NOT use this drawing for bodybuilding. Refer to Volvo Bodybuilder Instructions and chassis assembly drawing FML82RPTE.

# MODEL RANGE

## NEW FM Low Entry Battery Electric 8x2 Pusher & Tag Rigid - Full Air Suspension

### TRUCK USE

- **RC-SMOOT** Road Conditions - Smooth
- **GARB-PRE** Transport Adaption - Refuse preparation
- **TIPP-PRE** Transport Adaption - Tipper vehicle preparation
- **UNIFORM** Transport Adaption - Basic platform vehicle

### CORE COMPONENTS

- **CHH-MED** Chassis height - Medium - for loading heights check the unique BEP chassis drawing attached to this quote
- **PT-TEHY2** Pusher-tag tridem - Electro hydraulic steered pusher and tag axle, both with single wheel mounting
- **PT-TFID2** Pusher-tag tridem - Electro hydraulic steered pusher with fixed tag/dual wheel mounting
- **RAPDT-GR** Rear air suspension, 3 axles - 1 pusher/1 driven/1 tag
- **FMLE-CR** Cab - Low entry with steel safety cage design  
Designed and built to Swedish impact and ECE R29 regulations
- **FMLE-HCR** Cab - Low entry high roof with steel safety cage design  
Designed and built to Swedish impact and ECE R29 regulations
- **ESS360K** Energy storage system - Total energy 360 kWh
- **EPT2412** Gearbox - I-shift Automated 12-speed - suitable for gross train weights up to 44tonne
- **NEM2** Electric Motors - 2 - Output 330 kW - 450hp continuous power
- **RSS1344C** Drive axle - RS1344C single reduction with differential lock - design GCW 44 tonne
- **RSS1344E** Drive axle - RSS1344E single reduction with differential lock - design GCW 44 tonne
- **RSS1370A** Drive axle - RSS1370A single reduction 13 tonne with differential lock - design GCW 70 tonne

### PACKAGES

- **INFOHIGH** Media Information Platform - Medium level
- **DRIV-EXT** Cab package - Drive Extended
- **DRIV-SEL** Cab Package - Drive Select
- **RANGOP5** Range Optimisation Package - 5 years prepaid subscription

### CHASSIS

- **FST-AIR** Front suspension type - Air
- **FSL5-BAS** Front suspension levelling - basic stroke
- **FAL10.0** Front axle design capacity - 10 tonne - check tyre capacity
- **FAL8.0** Front axle design capacity - 8.0 tonne - check tyre capacity
- **FAL8.5** Front axle design capacity - 8.5 tonnes
- **FAL9.0** Front axle design capacity - 9.0 tonne - check tyre capacity
- **FALIM** Front axle load limiter
- **FSTAB2** Front anti-roll bar - Medium stiffness
- **FSTAB3** Front anti-roll bar - High stiffness
- **RAL27** Rear bogie design capacity - 27 tonne
- **RSTAB3** Rear anti-roll bar - Stiff
- **RALIM105** Rear-axle load limiter - 10.5 tonne - speed controlled
- **RALIM115** Rear-axle load limiter -11.5 tonne - speed controlled
- **RALIM13** Rear-axle load limiter - 13 tonne
- **ASF-DL1** Air suspension with 1 driving level
- **ACTST-TO** Active Steering- Volvo Dynamic Steering - VDS - with extra electronic pump and torque overlay
- **ASFE-BAS** Active steering feature - Basic - Volvo Dynamic Steering - VDS - only
- **ASFE-OG** Active steering feature - Volvo Dynamic Steering - VDS - with stability assist - oversteer
- **ASFE-PO** Active steering feature - Volvo Dynamic Steering - VDS - with personal settings and stability assist
- **ASFE-PS** Active steering feature - Volvo Dynamic Steering - VDS - with personal settings

- **RST-AIR** Rear suspension type - Air
- **FRAME300** Chassis frame section external height - 300 mm
- **FST8080** Chassis frame thickness - 8 mm web and flange
- **FIL-EEEB** Chassis frame inner liner - From the end of the engine to the end of the bogie
- **FIL-EEEF** Chassis frame inner liner - From the end of the engine to end of the frame
- **FIL-TXEB** Chassis frame inner liner - From gearbox member to the end of the bogie
- **FIL-TXEF** Chassis frame inner liner - From gearbox member to the end of the frame
- **BATTAMP** Battery management - Voltage and current gauge
- **BATTIND** Battery management - Voltage, current and charge indicators
- **WHC-FIX2** Wheel chocks - Two fixed design
- **WHC-FOL2** Two foldable wheel chocks
- **WHCP-M** Wheel chock carrier position - Middle part of the vehicle
- **WHCP-R** Wheel chock carrier position - In the rear part of the vehicle
- **WHCP-T** Wheel chock carrier position - Outer luggage locker
- **SUP-BAS** Side guards - Check with bodybuilder chassis space requirements
- **CHAIN-S** Snow chains
- **HOOK-SC** Snow chain hooks
- **TOWF-NO1** Front towing device - One detachable - stored in cab
- **TOWF-NO2** Front towing device - Two detachable - stored in cab
- **RFEC-S** Rear frame profile - Straight cut
- **RFEC-U** Rear frame profile - Slight uppercut for tippers
- **TOWR-ONE** Towing hitch attached to rear crossmember
- **RFEND-B** Rear mud wings - Three piece EC approved and spray flaps
- **RFEND-T** Rear mud wings - Temporary on drive axle for transport delivery only
- **RFH-BAS** Basic rear wing height
- **RFH-HIG** High rear wing height - higher wing tops
- **RFH-LOW** Lower rear wing height - shallower wing tops
- **BLIGHT-E** Emergency brake light

### WHEELS & TYRES

- **RT-AL** Wheels - Howmet Alcoa brushed aluminium rims - standard holes for long stud fixing
- **RT-ALDP** Wheels - Howmet Alcoa Dura-Bright aluminium rims - standard holes for long stud fixing
- **RT-ALDPD** Wheels - Howmet Alcoa Dura-Bright EVO aluminium rims - countersunk holes for short stud fixing
- **RT-ALDU** Wheels - Howmet Alcoa brushed aluminium rims - countersunk holes for short stud fixing
- **SPWT-D** Spare wheel & tyre with rear tyre pattern
- **SPWT-F** Spare wheel & tyre with front tyre pattern
- **SWCP-R** Rear mounted spare wheel carrier
- **SWCP-T** Spare wheel supplied temporarily strapped to chassis
- **SWCP-TP** Temporary spare wheel carrier on top of chassis frame
- **JACK-12T** 12 tonne bottle jack
- **JACK-15T** 15 tonne bottle jack
- **JACK-20T** 20 tonne bottle jack
- **TOOL-BAS** Basic Toolkit
- **TOOLKIT** Complete tool kit
- **INFLAHOS** Tyre inflation hose
- **GAUGE-TP** Tyre pressure gauge

### DRIVELINE EQUIPMENT

- **DRM-B** Drive mode - Balanced
- **DRM-BE** Drive mode - Balanced & Economy
- **PVT-MAP** I-See Predictive Cruise Control - using map-based topography information

- Standard Equipment
- Optional Equipment

For more detailed information about cab and powertrain equipment, please refer to separate specification sheets.

For all possible options and combinations of options please consult your Volvo sales contact who can create a specification to match your requirements using the Volvo Sales Support system (VSS).

The factory reserves the right to modify design and change equipment without previous notification. The specification can vary from country to country.

# MODEL RANGE

## NEW FM Low Entry Battery Electric 8x2 Pusher & Tag Rigid - Full Air Suspension

<input type="checkbox"/> <b>EP400A</b>	Electric Power Outlet Voltage - 400V AC	<input type="checkbox"/> <b>HWSS-AC</b>	Forward collision warning with adaptive cruise control WITHOUT AEBS advanced emergency brake system
<input type="checkbox"/> <b>EPTC270</b>	Electro-mechanical Power Take Off - Output 270 Nm - transport located on top of chassis behind cab	<input type="checkbox"/> <b>HWSS-ACB</b>	Forward collision warning with adaptive cruise control and AEBS advanced emergency brake system
<input type="checkbox"/> <b>HPM-F101</b>	Electric motor mounted hydraulic pump - Parker F1-101 for electrical motor, fixed displacement	<input checked="" type="checkbox"/> <b>HWSS-FCB</b>	Forward collision warning with AEBS advanced emergency brake system
<input type="checkbox"/> <b>HPM-F41</b>	Electric motor mounted hydraulic pump - Parker F1-41 for electrical motor, fixed displacement	<input type="checkbox"/> <b>LSS-DW</b>	Lane departure-warning system
<input type="checkbox"/> <b>HPM-F51</b>	Electric motor mounted hydraulic pump - Parker F1-51 for electrical motor, fixed displacement pum	<input checked="" type="checkbox"/> <b>LCS4</b>	Side Collision Avoidance Support - passenger and driver side
<input type="checkbox"/> <b>HPM-F61</b>	Electric motor mounted hydraulic pump - Parker F1-61 for electrical motor, fixed displacement	<input checked="" type="checkbox"/> <b>DAS-W</b>	Driver Alert Support system
<input type="checkbox"/> <b>HPM-F81</b>	Electric motor mounted hydraulic pump - Parker F1-81 for electrical motor, fixed displacement	<input type="checkbox"/> <b>RSENS-W</b>	Rain sensing windscreen wipers
<input type="checkbox"/> <b>HPM-T42</b>	Electric motor mounted hydraulic pump - Parker F2-42/42 for electrical motor, twin flow displacement	<input checked="" type="checkbox"/> <b>CU-ECC</b>	Cab climate Unit - Electrically controlled air conditioning with sun sensor
<input type="checkbox"/> <b>HPM-T53</b>	Hydraulic pump - F2-53/53 for electrical motor, twin flow displacement pump	<input type="checkbox"/> <b>CU-ECC2</b>	Cab climate Unit - Electrically controlled air conditioning with a carbon filter, sun, mist, and air quality sensor
<input type="checkbox"/> <b>HPM-T55</b>	Hydraulic pump - F2-55/28 for electrical motor, twin flow displacement pump	<input checked="" type="checkbox"/> <b>IMMOBIL</b>	Immobiliser
<input type="checkbox"/> <b>HPM-T70</b>	Hydraulic pump - F2-70/35 for electrical motor, twin flow displacement pump	<input type="checkbox"/> <b>ALARM-E</b>	Enhanced vehicle alarm - Thatcham H1 approved - Cab plus external sensor for body/trailer
<input type="checkbox"/> <b>HPM-V130</b>	Hydraulic pump - VP1-130 for electrical motor, variable displacement pump.	<input type="checkbox"/> <b>ISUNS-BS</b>	Side sun visor - Driver & passenger side
<input type="checkbox"/> <b>HPM-V45</b>	Hydraulic pump - VP1-45 for electrical motor, variable displacement pump.	<input checked="" type="checkbox"/> <b>ISUNS-DS</b>	Side sun visor - Driver-side
<input type="checkbox"/> <b>HPM-V75</b>	Hydraulic pump - VP1-75 for electrical motor, variable displacement pump.	<input type="checkbox"/> <b>ISUNF-RE</b>	Electrically operated textile interior sun blind
<input type="checkbox"/> <b>HPM-V95</b>	Hydraulic pump - VP1-95 for electrical motor, variable displacement pump.	<input checked="" type="checkbox"/> <b>ISUNF-RM</b>	Manually operated textile interior sun blind
<input type="checkbox"/> <b>PTR-D</b>	Gearbox PTO for plug-in pump, 0.71xeng speed	<input type="checkbox"/> <b>ADFS</b>	Two extra DIN slots in front shelf - can be fitted with card or drawer available as an accessory
<input type="checkbox"/> <b>PTR-DH</b>	Gearbox driven high speed PTO for one plug-in hydraulic pump	<input checked="" type="checkbox"/> <b>BUPALARM</b>	Reverse alarm
<input type="checkbox"/> <b>PTR-DM</b>	Gearbox driven medium speed PTO for one plug-in hydraulic pump	<input type="checkbox"/> <b>RTOLL-PK</b>	Road toll PREPARATION kit for trucks operating with "Toll Collect" in Germany
<input type="checkbox"/> <b>PTR-F</b>	Gearbox driven PTO with rear flange connection	<input checked="" type="checkbox"/> <b>LOADIND</b>	Load indicator with central dashboard display
<input type="checkbox"/> <b>PTR-FH</b>	Gearbox driven high speed PTO with SAE drive flange	<input type="checkbox"/> <b>REMC-MF</b>	Multi-functio wireless remote control
<input type="checkbox"/> <b>PTR-FL</b>	Gearbox driven low speed PTO with SAE drive flange	<input checked="" type="checkbox"/> <b>FIREXT3S</b>	Fire extinguisher - 3kg mounted on the seat base
<input type="checkbox"/> <b>PTRD-D</b>	Gearbox driven HIGH SPEED PTO for two plug-in hydraulic pumps	<input type="checkbox"/> <b>WARNVEST</b>	High visibility warning vest - No sleeves
<input type="checkbox"/> <b>PTRD-D1</b>	PTRD-D1 Gearbox driven HIGH SPEED PTO (1 SAE flange & 1 plug-in hydraulic pump)	<input checked="" type="checkbox"/> <b>WARNTRI2</b>	Roadside hazard warning triangle
<input type="checkbox"/> <b>PTRD-D2</b>	Gearbox driven HIGH SPEED PTO (2 SAE flanges & 1 plug-in hyd pump)	<input type="checkbox"/> <b>AIDKIT</b>	First aid kit - Legal demand for EU markets including delivery to EU bodybuilder
<input type="checkbox"/> <b>PTRD-F</b>	PTO with 1 DIN + 1 flange connection rear, manual gearbox	<input type="checkbox"/> <b>AIDKIT1B</b>	First aid kit - Legal demand for trucks transiting Germany
<input type="checkbox"/> <b>HPG-F101</b>	Gearbox mounted hydraulic pump - Parker F1-101 hydraulic pump gearbox mounted	<input type="checkbox"/> <b>WARNLAMP</b>	Portable warning lamp
<input type="checkbox"/> <b>HPG-F41</b>	Gearbox mounted hydraulic pump - Parker F1-41 gearbox mounted, fixed displacement, single flow	<input type="checkbox"/> <b>LAMP-IN</b>	Inspection lamp
<input type="checkbox"/> <b>HPG-F51</b>	Gearbox mounted hydraulic pump - Parker F1-51 gearbox mounted, fixed displacement, single flow	<input type="checkbox"/> <b>WRITEPAD</b>	Writing pad
<input type="checkbox"/> <b>HPG-F61</b>	Gearbox mounted hydraulic pump - Parker F1-61 gearbox mounted, fixed displacement, single flow	<input checked="" type="checkbox"/> <b>DST-CF4</b>	Driver seat - Suspended, adjustable shock absorber, travel, backrest & lumbar controls with integrated seatbelt
<input type="checkbox"/> <b>HPG-F81</b>	Gearbox mounted hydraulic pump - Parker F1-81 gearbox mounted, fixed displacement, single flow	<input type="checkbox"/> <b>DST-CF5</b>	Driver seat - Suspended with adjustable shock absorber, travel, backrest, lumbar & heat controls with integrated seatbelt
<input checked="" type="checkbox"/> <b>CRUIS-E</b>	Eco cruise control (with eco-roll and I-cruise, controls in steering wheel)	<input type="checkbox"/> <b>DST-CF6</b>	Driver seat - Suspended with adjustable shock absorber, travel, backrest, lumbar, heat and ventilation controls with integrated seatbelt
<input checked="" type="checkbox"/> <b>DTRI-PER</b>	Dashboard in darker peregrine greyish brown. Steering wheel grey and door panels in light beige for FH and black for FH16.	<input type="checkbox"/> <b>SBD-RED</b>	Seat belt colour - Red
<input checked="" type="checkbox"/> <b>STWPOS-R</b>	Steering wheel position - RIGHT-HAND DRIVE	<input type="checkbox"/> <b>PST-CF4</b>	Passenger seat - Suspended, adjustable shock absorber, travel, backrest & lumbar controls with integrated seatbelt
<input type="checkbox"/> <b>STWM-LE</b>	Steering wheel - Leather	<input type="checkbox"/> <b>PST-CF5</b>	Passenger seat - Suspended with adjustable shock absorber, travel, backrest, lumbar & heat controls with integrated seatbelt
<input type="checkbox"/> <b>STGW-AD2</b>	Steering wheel adjustment - Neck tilt, column height and angle	<input type="checkbox"/> <b>ARMRE-BB</b>	Armrests - Two on both driver & passenger seats
<input type="checkbox"/> <b>STGW-ADJ</b>	Steering wheel adjustment - Column height and angle	<input type="checkbox"/> <b>ARMRE-DB</b>	Armrests - Two on the driver seat
<input checked="" type="checkbox"/> <b>1DAYDIG4</b>	Smart tachograph - Continental VDO 4.1 version 2 - legal demand from 21/08/2023	<input type="checkbox"/> <b>ARMRE-PB</b>	Armrests - Two on the passenger seat
<input type="checkbox"/> <b>TAC-PK2</b>	Tachograph prep Kit	<input type="checkbox"/> <b>ARU-BAS</b>	Armrest upholstery - Vinyl
<input type="checkbox"/> <b>ARSL</b>	Additional road speed limit - switch in dashboard	<input type="checkbox"/> <b>ARU-LEA</b>	Armrest upholstery - Leather
<input type="checkbox"/> <b>ESP-BAS1</b>	Electronic Stability Control ESC	<input checked="" type="checkbox"/> <b>FMAT-RUB</b>	Footwell floor mats - Rubber
<input type="checkbox"/> <b>ESPC-RO</b>	Additional ESC functions - Reduced / Off	<input type="checkbox"/> <b>FMAT-TX2</b>	Footwell floor mats - Two sets, Rubber and textile with an embossed pile supplied in the cab
<input checked="" type="checkbox"/> <b>Standard Equipment</b>		<input checked="" type="checkbox"/> <b>RUS-BAS</b>	Rear cab upper storage - 300 mm high
<input type="checkbox"/> <b>Optional Equipment</b>		<input type="checkbox"/> <b>RUS-HIG</b>	Rear cab upper storage - 440 mm high - volume 245 litres

For more detailed information about cab and powertrain equipment, please refer to separate specification sheets.

For all possible options and combinations of options please consult your Volvo sales contact who can create a specification to match your requirements using the Volvo Sales Support system (VSS).

The factory reserves the right to modify design and change equipment without previous notification. The specification can vary from country to country.

# MODEL RANGE

## NEW FM Low Entry Battery Electric 8x2 Pusher & Tag Rigid - Full Air Suspension

<input type="checkbox"/> <b>REFR-RUS</b>	Fridge - 28 litre rear upper wall mounted with dividers	<input type="checkbox"/> <b>BEACON-P</b>	Roof beacons - switch and wiring preparation only
<input type="checkbox"/> <b>MICRO-PK</b>	Wiring preparation kit for microwave oven	<input type="checkbox"/> <b>BEACONA4</b>	Roof beacons - Four amber LED - two front/ two rear
<input type="checkbox"/> <b>COFMA-PK</b>	Coffee maker - Preparation kit.	<input type="checkbox"/> <b>CABPT-R1</b>	Single outlet for roof mounted accessories
<input checked="" type="checkbox"/> <b>INLI-BAS</b>	Interior light - White LEDs	<input checked="" type="checkbox"/> <b>CABPT-R2</b>	Twin outlets for roof mounted accessories.
<input type="checkbox"/> <b>INLI-NL</b>	Interior light - White and red nightlight LEDs without dimmer	<input type="checkbox"/> <b>SPOTP-F</b>	Spotlamp preparation in front, max 280W
<input type="checkbox"/> <b>INLI-NLD</b>	Interior light - White and red nightlight LEDs with dimmer	<input type="checkbox"/> <b>SPOTP-R</b>	Spotlamp preparation on roof, max 280W
<input type="checkbox"/> <b>ARL-FLEX</b>	Flexible reading lamps - Two "snake" type	<input type="checkbox"/> <b>SPOTP-RF</b>	Spotlamp preparation on cab roof and in cab front, max 2x280W
<input checked="" type="checkbox"/> <b>RH-EE</b>	Fixed tinted glass sky window with emergency exit	<input type="checkbox"/> <b>ROS-IL</b>	Globetrotter roof sign illuminated
<input type="checkbox"/> <b>RH-ER</b>	Steel roof hatch - Electrically operated, rear opening with emergency exit	<input type="checkbox"/> <b>ROS-IL2</b>	Preparation kit for illuminated roof sign with switch loose in cab, fit after registration
<input type="checkbox"/> <b>RH-ETR</b>	Tinted glass roof hatch - Electrically operated, rear opening with emergency exit	<input type="checkbox"/> <b>ROS-ILP</b>	Roof sign illumination preparation kit
<input type="checkbox"/> <b>RH-MTR</b>	Tinted glass roof hatch - Manually operated, rear opening with emergency exit	<input type="checkbox"/> <b>CSGN-GTR</b>	Cab sign logo - FH "Globetrotter" or FH16 "Power"
<input checked="" type="checkbox"/> <b>GLAS-TIN</b>	Cab windows - Tinted	<input type="checkbox"/> <b>HORN-R2S</b>	Horn - Air - Two roof-mounted
<input type="checkbox"/> <b>AWIND-RF</b>	Rear window	<input type="checkbox"/> <b>ANT-CBR</b>	Roof mounted antenna for CB radio, single aerial. Only Globetrotter cabs brings in extra DIN slots.
<input type="checkbox"/> <b>SWIND-BS</b>	Cab side window - On both sides behind 'B' post	<input type="checkbox"/> <b>ACCBR-F</b>	Front roof mounted accessory bracket
<input type="checkbox"/> <b>SWIND-PS</b>	Cab side window - Left side behind 'B' post	<input type="checkbox"/> <b>ACCBR-FR</b>	Front & rear roof mounted accessory brackets
<input type="checkbox"/> <b>VANMIR</b>	Vanity mirror - In front shelf	<input type="checkbox"/> <b>ACCBR-R</b>	Rear roof mounted accessory bracket
<input type="checkbox"/> <b>AS-FUS</b>	Extra shelf in front compartments	<input type="checkbox"/> <b>REFS-TW</b>	White cab conspicuity markings by packed in cab
		<input type="checkbox"/> <b>REFS-TY</b>	Yellow cab conspicuity markings by packed in cab
<b>CAB EXTERIOR</b>		<b>SUPERSTRUCTURE PREPARATIONS</b>	
<input checked="" type="checkbox"/> <b>EXTL-BA2</b>	Enhanced exterior finish - Satin Volvo badges, instep, bumper, and mirror housing in cab colour. Main grille in thunder grey. Aluminium step inserts. Sunvisor and bumper spoiler in cab colour if specified.	<input type="checkbox"/> <b>SRWL-2RW</b>	Chassis-mounted working lamps - Two white rear-mounted LED lamps and 3 position switch
<input checked="" type="checkbox"/> <b>DGLAS-L</b>	Door glass - Laminated	<input type="checkbox"/> <b>SRWL-PK</b>	Chassis-mounted working lamps - Side work and reverse lamp preparation and 3 position switch - Max load 280W
<input checked="" type="checkbox"/> <b>BUMP-B</b>	Front bumper - Plastic	<input type="checkbox"/> <b>SWL-2RW</b>	Chassis-mounted working lamps - Two white rear mounted LED lamps
<input checked="" type="checkbox"/> <b>CTILT-P-E</b>	Electrically operated hydraulic cab tilt	<input type="checkbox"/> <b>SWL-PK</b>	Chassis-mounted working lamps - Side work lamp preparation and 2 position switch - Max load 280W
<input checked="" type="checkbox"/> <b>FCABS-M</b>	Front cab suspension - Mechanical spring	<input type="checkbox"/> <b>WLC-H2W</b>	Working lamp back of cab - Two white LED high mounted at the back of cab
<input checked="" type="checkbox"/> <b>RCABS-A</b>	Rear cab suspension - Air	<input type="checkbox"/> <b>WLC-PKH</b>	Working lamp back of cab - Preparation kit - cables and switch
<input checked="" type="checkbox"/> <b>HCC-EXT</b>	Exterior hood catch - manually operated from the front of the vehicle	<input type="checkbox"/> <b>WLC-PKH</b>	Preparation kit, cables and switch for high mounted working lamps back of cab
<input type="checkbox"/> <b>MIRCFCPX</b>	Mirrors - Electrically heated and operated - FMX- main and wide-angle with manually adjusted kerb view mirror on the passenger side and position camera in nearside mirror arm. To increase direct vision to the side the main mirrors have no cowlings	<input type="checkbox"/> <b>ECBB-BAS</b>	Bodybuilder electrical centre without bodybuilder module
<input type="checkbox"/> <b>MIRCMCP</b>	Camera monitoring and mirrors - Electrically heated and operated main and wide-angle rear view cameras with manually adjusted passenger kerb and front mirror and passenger corner pedestrian camera.	<input checked="" type="checkbox"/> <b>ECBB-HIG</b>	Bodybuilder module - High level body electrical centre in dash input/output module
<input type="checkbox"/> <b>MIRCMS</b>	Camera monitoring and mirrors - Electrically heated and operated main and wide-angle rear view cameras with manually adjusted passenger kerb and front mirror	<input type="checkbox"/> <b>BBCHAS1</b>	One 7-pole connector for Body builder interface
<input type="checkbox"/> <b>MIRCMPFX</b>	Electrically heated and operated -FMX- main and wide-angle mirrors with manually adjusted passenger kerb mirror, to increase direct vision to the side the main mirrors have no cowlings	<input type="checkbox"/> <b>BBCHAS3</b>	Three 7-pole connectors for Body builder interface
<input checked="" type="checkbox"/> <b>AMIR-F20</b>	Auxiliary front view mirror with a 200mm radius	<input type="checkbox"/> <b>BEPR-T2</b>	Body builder electrical software preparation for tipper with remote control
<input type="checkbox"/> <b>AD-ROOF</b>	Cab roof deflector - Adjustable	<input type="checkbox"/> <b>EXSTER</b>	External steering control - Volvo dynamic steering and bodybuilder module prepared for external control system, installed and computer by bodybuilder
<input checked="" type="checkbox"/> <b>AD-SIDES</b>	Cab side deflector - Short extension panels	<input type="checkbox"/> <b>FBA-BTF</b>	Lower front body attachments for torsionally flexible - platform body
<input type="checkbox"/> <b>ADCF-F</b>	Additional black edging on chassis side skirt	<input type="checkbox"/> <b>FBA-BTSF</b>	Lower front body attachments for torsionally semi-flexible body - box or curtainsider
<input checked="" type="checkbox"/> <b>HL-LED</b>	Headlights - LED	<input type="checkbox"/> <b>HBA-FSFB</b>	Holes for body attachments - flexible/semi-flexible body
<input checked="" type="checkbox"/> <b>DRL-LED</b>	Daytime running lights - V shaped	<input type="checkbox"/> <b>HBA-SB</b>	Holes for body attachments - stiff body
<input checked="" type="checkbox"/> <b>UDRIVL</b>	Auxiliary driving lights - Without	<input type="checkbox"/> <b>RBA-T2</b>	Lower rear body attachments for helper frame
<input type="checkbox"/> <b>ASL-RF2</b>	Integrated roof spotlights - Two LED spot lights in Globetrotter sign box	<input type="checkbox"/> <b>CRANEPK1</b>	Crane plates mounted to frame, for cranes up to 10 tonne metre capacity
<input type="checkbox"/> <b>BEACOA2F</b>	Roof beacons - Two front roof mounted amber LED	<input type="checkbox"/> <b>CRANEPK2</b>	Crane plates mounted to frame, for cranes up to 20 tonne metre capacity
<input type="checkbox"/> <b>BEACOA2R</b>	Roof beacons - Two rear roof mounted amber LED	<input type="checkbox"/> <b>CRANEPK4</b>	Crane plates mounted to frame, for cranes up to 40 tonne metre capacity
<input type="checkbox"/> <b>AESW2</b>	Two Body builder bistable electrical switches (marked AUX1 / AUX2)	<input type="checkbox"/> <b>TAILPRE2</b>	Tail lift preparation kit, wireless remote operation
<input type="checkbox"/> <b>AESW2PK</b>	2 Body builder bistable el.switches (marked AUX1/AUX2) and prep. for 4 more switches	<input type="checkbox"/> <b>TAILPREP</b>	Taillift preparation kit - cab switch and warning in driver display

Standard Equipment       Optional Equipment

For more detailed information about cab and powertrain equipment, please refer to separate specification sheets.

For all possible options and combinations of options please consult your Volvo sales contact who can create a specification to match your requirements using the Volvo Sales Support system (VSS).

The factory reserves the right to modify design and change equipment without previous notification. The specification can vary from country to country.

# MODEL RANGE

## NEW FM Low Entry Battery Electric 8x2 Pusher & Tag Rigid - Full Air Suspension

---

- **AUXSW-4** Wiring for 4 extra switches (from Body builder electrical centre to switch positions)

### DELIVERY SERVICES

- **DRUT1** Driver utility app - "My Truck" - 1 year subscription  
For mobile phone, tablet, with android and IOS systems.  
Only available with Volvo Connect subscription
- **DRUT2** Driver utility app - "My Truck" - 2 year subscription  
For mobile phone, tablet, with android and IOS systems.  
Only available with Volvo Connect subscription
- **DRUT3** Driver utility app - "My Truck" - 3 year subscription  
For mobile phone, tablet, with android and IOS systems.  
Only available with Volvo Connect subscription
- **DRUT4** Driver utility app - "My Truck" - 4 year subscription  
For mobile phone, tablet, with android and IOS systems.  
Only available with Volvo Connect subscription
- **DRUT5** Driver utility app - "My Truck" - 5 year subscription  
For mobile phone, tablet, with android and IOS systems.  
Only available with Volvo Connect subscription