

MODEL RANGE

FM13 6x4 Rigid Air Suspension FM 64R 3A

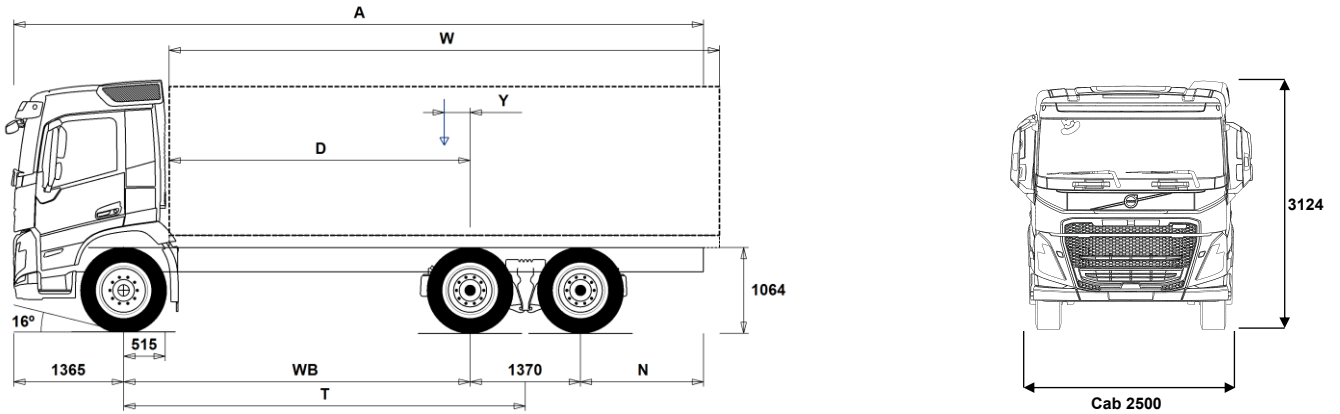

Chassis Dimensions [mm]

WB Wheelbase	3200	3400	3700	3900	4600	4900
A Overall Chassis Length	7710	7310	8460	8760	10560	10310
D Center of rear axle to front of body	2635	2835	3135	3335	4035	4335
N Rear Overhang (Min.)	825	825	825	825	825	825
N Rear Overhang (Max.)	1775	1175	2025	2125	3225	2675
T Theoretical Wheelbase	3885	4085	4385	4585	5285	5585
Y Center of Gravity for Payload (Min.)	-201	-186	-142	-119	-29	-7
Y Center of Gravity for Payload (Max.)	-201	-186	-142	-119	-29	-7
W Body Length (Min.)	5651	5971	6451	6771	7891	8371
W Body Length (Max.)	5651	5971	6451	6771	7891	8371

Chassis Weights [kg]

Front Axle	4635	4670	4655	4660	4670	4710
Rear Bogie	3410	3360	3440	3450	3595	3545
Kerb Weight	8045	8030	8095	8110	8265	8255
Payload (including body, driver, fuel, etc.)	14955	14970	14905	14890	14735	14745

Turning Diameter [mm]

Turning Circle Diameter Kerb to Kerb	13900	14500	15500	16100	18200	19100
Turning Circle Diameter Wall to Wall	15300	15900	16900	17500	19600	20500

Plated Weights [kg]

	Plated	Design
Gross Vehicle Weight	23000	28100
Gross Combination Weight	40500	44000
Front Axle	6500	7100
Rear Bogie	16500	21000

Important Notes

Chassis Dimensions

Cab Height: +328 mm for CAB-HSLP, -262 mm for CAB-LDAY, -262 mm for CAB-LSLP, +16 mm for CAB-SLP.
 Front Axle to Back of Cab: +431 mm for CAB-HSLP and CAB-SLP, -69 mm for CAB-LDAY, +425 mm for CAB-LSLP.
 D-measure includes a front clearance of 50 mm and for rigid trucks also a subframe of 100 mm.
 Height can vary ± 20 mm for leaf and ± 10 mm for air suspension.
 All dimensions are for unladen chassis and any tag axles down. Chassis height used: CHH-HIGH.
 Rear overhang used for vehicle weight calculation is the maximum rear overhang (N Max.) for selected wheelbase.
 Height change when chassis height CHH-MED,FRAME300: 0 mm.

Weight and dimensions are based upon the following tyres:
 Front Axle Tyres: 315/80R22.5
 Drive Axle Tyres: 315/80R22.5

Chassis weight includes oil, water, AdBlue, 0 litres fuel and without driver. Kerb weight can vary ± 3%.

Turning diameters are theoretically calculated.

Legal weights can differ from country to country.

For more detailed weight information, including optional equipment weights, ask your Volvo sales contact to enter your specification into the Volvo Weight Information system (WIS).

Do NOT use this drawing for bodybuilding. Refer to Volvo Bodybuilder Instructions and chassis assembly drawing FM64R3A.

MODEL RANGE

FM13 6x4 Rigid Air Suspension FM 64R 3A

Truck use

- RC-ROUGH** Operating class on/off road
- RC-SMOOTH** Well Maintained Surfaced Roads >95% Driving Distance
- GARB-PRE** Garbage Preparation
- SWAPBODY** Swap body carrier-torsion flex interchange
- TIPP-PRE** Tipper preparation
- UNIFORM** Basic uniform vehicle

Core components

- CHH-HIGH** Chassis Height High approx. 1025-1050mm (depending on tyre selection)
- CHH-LOW** Chassis height low approx. 850 mm
- CHH-MED** Approximate chassis height 900 mm
- CHH-XHIGH** Chassis Height Extra High approx. 1100-1162mm (depending on tyre selection)
- RADD-G2** Rear Air Suspension - High Clearance
- RADD-GR** Rear Air Suspension
- CDCOPREP**
- FM-CREW** Crewcab (additional Free Text CA required CREWCAB CABL362)
- FM-DAY6** Day Cab
- FM-HSLP6** Globetrotter Cab
- FM-LDAY6** Low Day Cab
- FM-LSLP6** Low Sleeper Cab
- FM-SLP6** Sleeper Cab
- EU4SCR** Eu4 SCR (Selective Catalytic Reduction)
- EU5EEV** Eu5 SCR Enhanced Environmentally friendly Vehicle
- EU5SCR-M** Eu5 SCR Selective Catalytic Reduction (mandatory)
- EU6SCR** Eu6 SCR (Particulate Filter & EGR) Single Stage Turbo
- D13S420A**
- D13S460A** Eu6 Fuelface 13 litre 460hp Engine
- D13S500A** Eu6 Fuelface 13 litre 500hp Engine
- D13A380** Eu3 Engine, 13A litre, 380 hp, 1900 Nm
- D13A420** Eu4 SCR engine, 13A litre, 520 hp, 2500 Nm
- D13A460** Eu4 SCR engine, 13A litre, 460 hp, 2100 Nm
- D13A500** Eu4 SCR engine, 13A litre, 500 hp, 2500 Nm
- D13C380** Eu5 SCR engine, 13C litre, 380hp, 1900nm
- D13C420** Eu5 SCR engine, 13C litre, 420hp, 2100nm
- D13C460** Engine, 13C litre, 460hp, 2300nm
- D13C500** Engine, 13C litre, 500hp, 2500nm
- D13K420** Eu6 13 litre Engine 420hp/2100nm/309kW
- D13K460** Eu6 13 litre Engine 460hp/2300nm/345kW
- D13K500** Eu6 13 litre Engine 500hp/2500nm/368kW
- EBR-EPG** Exhaust Pressure Governor
- EBR-EPGC** Engine Brake Compression EPG
- EBR-VEB** Volvo Engine Brake (VEB)
- EBR-VEB+** Volvo Engine Brake + (VEB+)
- AT2412** Volvo I-shift 12 Speed Automatic Transmission (2400nm)
- AT2612** Volvo I-shift 12 Speed Automatic Transmission (2600nm)
- AT2812** Volvo I-shift 12 Speed Automatic Transmission (2800nm)
- ATO2612** Volvo I-shift 12 Speed Automatic Transmission with Overdrive (2600nm)
- ATO3112** Volvo I-shift Automatic Transmission with Overdrive (3150nm)
- PT2606** Powertronic 6 Speed Transmission (2600nm)
- SPO2812** Volvo Dual Clutch I-shift - 12 Speed Semi Power Shift with Overdrive (2800nm)
- ASO-C** Crawler Gears
- ASO-ULC** Ultra Low Crawler Gears
- TAAXLIFT** Tandem axle lift
- RTH2610B** Volvo RTH2610B hub reduction rear axles
4 planet gears per hub
Axle rating: 26,000 kg
115 tonne train weight
(Application approved)
- RTH2610F** Hub Reduction Tandem 26t GCW100t (version F)
- RTS2310A** Single Reduction Tandem 23t GCW100t
- RTS2370A** Rear single reduction tandem axles
Axle rating: 23,000 kg
Cross axle diff lock & power divider

Standard Equipment

Optional Equipment

For more detailed information about cab and powertrain equipment, please refer to separate specification sheets.

For all possible options and combinations of options please consult your Volvo sales contact who can create a specification to match your requirements using the Volvo Sales Support system (VSS).

The factory reserves the right to modify design and change equipment without previous notification. The specification can vary from country to country.

- PTO-HT16**
- PTO-HT20**

Packages

- 1LIVINFM** 1 bed resting package
- 2LIVINFM** 2 bed resting package
- INFOBASE** Standard Level Information Platform
- INFOHIGH** High Level Information Platform
- SAFEBAS**
- SAFEBAS2**
- SAFEPLU2**
- SAFEPLUS**
- OFFROADD** Construction package on Day Cab
- OFFROADS** Construction package on Sleeper Cab
- CHASPAC** Chassis Package - Rigid

Chassis

- FST-AIR** Air Bag Front Suspension
- FST-PAR** Parabolic leaf spring front suspension
- FST-PAR3** 3 Leaf Parabolic Front Springs (stiffer than normal)
- FSLB-BAS** Front Suspension Levelling Stroke - Standard
- FSLB-HI** Front Suspension Levelling Stroke - High
- FAL10.0** Front Axle Load 10 tonnes
- FAL7.1** Front axle load 7.1 tonnes
- FAL7.5** Front Axle Load 7.5 tonnes
- FAL8.0** Front axle load 8.0 tonnes
- FAL8.5** Front Axle Load 8.5 tonnes
- FAL9.0** Front axle load 9.0 tonnes
- FSTAB** Front stabilizer, normal stiffness
- FSTAB2** Front stabiliser bar increased stiffness
- FSTAB3** Heavy duty front stabiliser bar
- RAL21** Rear suspension load rating: 21,000 kg
- RAL23** Rear Axle Load 23 tonnes
- RAL26** Rear suspension load rating: 26,000 kg
- RSTAB1** Rear stabiliser bar
- RSTAB3** Heavy duty rear stabiliser bar
- RALIM105** Rear axle load limiter 10.5 tonnes (speed controlled)
- RALIM115** Rear axle load limiter 11.5 tonnes (speed controlled)
- RALIM13** Rear axle load limiter 13.0 tonnes
- RALIM15** Rear axle load limiter 15.0 tonnes
- RALIM95** Rear axle load limiter 9.5 tonnes
- ASF-DL1** Air susp. feature - 1 driving level
- ASF-DL3** Air susp. feature - 3 driving levels
- ACTST-TO** Volvo Dynamic Steering
- ASFE-BAS** Dynamic steering features - Standard
- ASFE-OG** Dynamic Steering Active Features - Oversteer Guidance
- ASFE-PO** Dynamic Steering Active Features - Personal Settings & Oversteer Guidance
- ASFE-PS** Dynamic Steering Active Features - Personal Settings
- PSS-SING** Single power steering system
- PSP-FIX** Power Steering Pump with Fixed Displacement
- PSP-VAR** Power Steering Pump with Variable Displacement
- PSP-VAR2** Power Steering Pump with Electronic Control Variable Displacement
- EBS-MED** Electronic Brake System (EBS) contains ABS, Traction control, Hill start aid
Diff lock control, Brake assist
Wheel brake monitoring, EBS status
- EBS-STD** Electronic Brake System (EBS) contains ABS, Traction control, BCS
- AUXPARK** Auxiliary parking brake
- RST-AIR** Rear Air Suspension
- FRAME266** Frame rail height 266mm
- FRAME300** Frame rail height 300mm

MODEL RANGE

FM13 6x4 Rigid Air Suspension FM 64R 3A

- FST7070** Frame Section Thickness 7mm
- FST8080** Frame Section Thickness 8mm
- FIL-EEEB** Liner (inner) from end of engine to end of bogie
- FIL-EEEF** Liner (inner) from end of engine to end of frame
- FIL-FBEB** Liner (inner) - front of bogie to end of bogie
- FIL-FBEF** Liner (inner)- front of bogie to end of frame
- FIL-TXEB** Liner (inner) - trans x-mem to end of bogie
- FIL-TXEF** Liner (inner) - trans x-mem to end of frame
- BBOX-L** Battery box mounted on LHS chassis rail
- BATS-D** Battery system - dual
- BATS-S** Battery system - single
- 2BAT210B** Two Batteries 210 Ah Gel
- 2BAT210C** Two Batteries 210 Ah AGM
- 2BATT170** Two Batteries 170 Ah
- 2BATT225** 2x225 Ah batteries
- BATTAMP** Battery Amperage Indicator (in the DID)
- BATTIND** Battery Charge Indicator (in the DID)
- ADR1** Standard ADR adaption - 1 switch
- ADR2** Standard ADR adaption - 2 switches
- MSWI-A** Main Switch ADR
- MSWI-C** Isolation Toggle Switch LHS of Chassis
- MSWI-R** Isolation Switch on Key Fob (Press Door Lock Twice to Isolate)
- R405A71** Right aluminium 710 mm D-shaped fuel tank, 405 litres volume.
Usable volume is 97% of stated volume.
Min volume 255l
Max volume 810l
- UL-FUEL** LHS fuel tank not fitted
Min volume 160l
Max volume 730l
- ADTP-L** AdBlue Tank Position - LHS
- ADTP-R** AdBlue Tank Position - RHS
- ADB048** AdBlue Tank 48 litres
- ADB064** AdBlue Tank 64 litres
- ADB068** AdBlue Tank 68 litres
- ADB083** AdBlue Tank 83 Litres
- ADB090** AdBlue Tank 90 litres
- ADB100** AdBlue Tank 100 litres
- ADB112** AdBlue Tank 112 Litres
- ADTC-BF** AdBlue Tank Cover - Bright Finish
- FCAP-L** Fuel tank cap with lock
- FUFF-AS** Fuel filling feature - anti spillage
- FUFF-ATS** Fuel filling feature - anti theft & spillage
- ESH-LEFT** Muffler horizontal, left exhaust outlet
- ESH-REAR** Low Mounted Muffler with Low Rear Facing Outlet
- ESH-RIGH** Muffler horizontal, right exhaust outlet
- ESH-VERT** Muffler horizontal, vertical exhaust outlet on right hand side
- ESV-VERT** Single vertical exhaust/ vertical outlet
- EXST-SSP** Stainless Steel Exhaust Stack
- HS-NAR** Heat shield-narrow
- WHC-FIX2** Wheel chocks, qty 2 fixed
- WHC-FOL2** Wheel chocks, qty 2 foldable
- WHCP-F** Wheel chocks position, front
- WHCP-M** Wheel chocks position, middle
- WHCP-R** Wheel chocks position, rear
- WHCP-T** Wheel chocks, transport mounted
- TB-L80** Toolbox 800 mm, left side
- TB-R80** Toolbox 800 mm, right side
- SUP-BAS** Side underrun protection - standard
- SUP-LOW** Side underrun protection - low
- CHAIN-S** Snow chains

- HOOK-SC** Hooks for snow chains
- TOWF-NO1** One Towing Device - Front
- TOWF-NO2** Two Towing Devices - Front
- TOWMBRH** Tow member high mounting
- TOWMBRL1** Tow member low mounting position 1
- TOWMBRL2** Tow member low mounting position 2
- TOWMBRL3** Tow member low mounting position 3
- TOWMBRM** Tow member medium mounting
- C-RI4040** Tow coupling Ringfeder 4040 G-150
- C-RI4045** Tow coupling Ringfeder 4045 G-150
- C-RI5050**
- C-RO400G** Tow coupling Rockinger 400 G150
- C-RO50** Tow coupling Rockinger 50
- C-VBG520**
- C-VBG795**
- TOWR-ONE** Single tow device
- TREL-PK** Trailer connection prep
- TREL14** 14 pin elec. trailer connection
- TREL15** 15 pin elec. trailer connection
- TREL7** 7 pin elec. trailer connection (24N)
- TREL7-7** 2x7 pin elec. trailer connectors (24N & 24S)
- TRBR-HCF** Hand controlled trailer brake, full pressure
- TRBR-HCR** Hand controlled trailer brake, reduced pressure
- TRBR-STA** Stationary Trailer Brake Control
- TRB-STRE** Automatic Trailer Brake Activation (Stretch Brake)
- RUP-FOLD** Rear underrun prot. - foldable
- RUP-FOSL** Rear underrun prot. - foldable sliding
- RFEND-B** Rear mudguards - standard
- RFEND-T** Transport rear mudguards
- RFH-HIG** Highest possible mudguard height
- RFH-LOW** Lowest possible mudguard height
- AUXATNK** Auxiliary airtank
- ATANK-AL** Aluminium airtanks
- TL-LED** LED Tail Lights
- BLIGHT-E** Emergency Brake Lights
- FRACLOS** With frame closing

Rims and Tyres

- RT-AL** 10 Stud Alloy Disc Rims (with long wheel studs)
- RT-AL1**
- RT-AL1DU**
- RT-ALDP** 10 Stud Dura-Bright Alloy Disc Rims (with long wheel studs)
- RT-ALDPD** 10 Stud Dura-Bright Alloy Disc Rims (with short wheel studs)
- RT-ALDU** 10 Stud Alloy Disc Rims (with short wheel studs)
- RT-ALP** 10 Stud Polished Alloy Disc Rims (with long wheel studs)
- RT-ALPDU** 10 Stud Polished Alloy Disc Rims (with short wheel studs)
- RT-STEEL** 10 Stud Steel Disc Rims
- WCAP** Wheel caps
- SPWT-D** Spare rim & tyre equal to drive
- SPWT-F** Spare rim & tyre equal to steer
- SWCP-LF** Spare Wheel Carrier Front of Drive Axle. LHS
- SWCP-R** Spare Wheel Carrier Behind Drive Axle
- SWCP-T** Spare wheel supplied temporarily strapped to chassis
- SWCP-TP** Transport mounted spare wheel on top of frame
- JACK-12T** 12 tonne capacity jack with brace
- JACK-15T** 15 tonne capacity jack and brace
- JACK-20T** Jack - 20 Tonnes
- TOOL-BAS** Basic tools
- TOOLKIT** Tool kit complete
- INFLAHOS** Tyre inflation hose (18 metres)
- GAUGE-TP** Tyre pressure gauge

Powertrain equipment

- Standard Equipment
- Optional Equipment

For more detailed information about cab and powertrain equipment, please refer to separate specification sheets.

For all possible options and combinations of options please consult your Volvo sales contact who can create a specification to match your requirements using the Volvo Sales Support system (VSS).

The factory reserves the right to modify design and change equipment without previous notification. The specification can vary from country to country.

MODEL RANGE

FM13 6x4 Rigid Air Suspension FM 64R 3A

<input type="checkbox"/> TRAP-HD	Heavy Duty Transmission Internals	<input type="checkbox"/> PTRD-D2	PTO with 2 flange connection rears + 1 DIN connection front
<input checked="" type="checkbox"/> DRM-BE	Drive Mode - Balanced & Economy	<input type="checkbox"/> PTRD-F	PTO with 1 DIN + 1 flange connection rear
<input type="checkbox"/> DRM-E	Drive Mode - Economy	<input type="checkbox"/> HPG-F101	F1-101 hydraulic pump gearbox mounted
<input type="checkbox"/> PVT-BAS	Standard - by GPS positioning	<input type="checkbox"/> HPG-F41	F1-41 hydraulic pump gearbox mounted
<input type="checkbox"/> PVT-MAP	Preview Topography Information (High Resolution Topography Map)	<input type="checkbox"/> HPG-F51	F1-51 hydraulic pump gearbox mounted
<input checked="" type="checkbox"/> CRUIS-E	Extended Cruise Control (Additional Fuel Saving Functions)	<input type="checkbox"/> HPG-F61	F1-61 hydraulic pump gearbox mounted
<input type="checkbox"/> CRUIS-E5	Cruise Control (I-Torque)	<input type="checkbox"/> HPG-F81	F1-81 hydraulic pump gearbox mounted
<input type="checkbox"/> AMSO-AUT	Manual gear shift in automatic mode.	<input type="checkbox"/> STWM-LE	Steering wheel material - leather
<input type="checkbox"/> AVO-ENH	AMT Vocational option - enhanced	<input type="checkbox"/> DRC-AMII	DPF Regeneration- Auto Initialise/Manual on Demand/Manual Inhibit
<input type="checkbox"/> APF-ENH	Enhanced I-shift PTO functions	<input checked="" type="checkbox"/> DRC-AUTO	DPF Regeneration- Fully Automatic (in motion)
<input type="checkbox"/> RET-TH	Retarder for manual gearbox	<input type="checkbox"/> 1DAYB	1DAY-STD/SI-GRAF/basic setting
<input type="checkbox"/> RET-TPT	Compact durable design with easy control	<input type="checkbox"/> 1DAYDIG	1DAY-STD/SI-GRAF/digital
<input type="checkbox"/> RET-TPT	Retarder for Powertronic Transmission	<input checked="" type="checkbox"/> 1DAYDIG4	
<input type="checkbox"/> TC-HWO	Transmission Oil Cooler	<input type="checkbox"/> ARSL	Additional road speed limiter
<input type="checkbox"/> TC-MAOH2	High performance transmission cooler	<input type="checkbox"/> SPEED-DU	Dual speed limiter
<input type="checkbox"/> TC-MWO	High performance transmission cooler	<input checked="" type="checkbox"/> ACCLF-D	Acceleration Limiting Feature - Disabled
<input type="checkbox"/> TC-MWOH2	High performance transmission cooler	<input type="checkbox"/> ACCLF-E	Acceleration Limiting Feature - Enabled
<input type="checkbox"/> 2COM1080	High volume air compressor	<input checked="" type="checkbox"/> ESP-BAS1	ESP Package (Tractor/Trailer Combinations with ABS/EBS Or Rigid with Standard COG)
<input type="checkbox"/> 2COM1100	Air Compressor - 1100 litres/minute	<input type="checkbox"/> ESPC-RO	ESP functionality control reduced/off
<input checked="" type="checkbox"/> 2COMP870	Air Compressor - 870 litres/minute	<input type="checkbox"/> HWSS-AC	ACC & Forward Collision Warning
<input type="checkbox"/> 2COMP900	Air Compressor - 900 litres/minute	<input type="checkbox"/> HWSS-ACB	ACC & forward collision warning & emergency braking.
<input type="checkbox"/> CLU-AIRC	Clutchable air compressor	<input checked="" type="checkbox"/> HWSS-FCB	Forward Collision Warning including Emergency Braking
<input checked="" type="checkbox"/> AIRIN-HI	High air intake, roofline position	<input checked="" type="checkbox"/> LSS-DW	With lane departure system
<input type="checkbox"/> AIRIN-LO	Low air intake, rear of cab position	<input type="checkbox"/> LSS-DW3	Pilot Assist - Active Continuous Lane Keeping
<input type="checkbox"/> ACL1ST-S	Air cleaner with two stage filter element	<input type="checkbox"/> LCS2	Lane Change Support with Side Collision Avoidance (LHS)
<input checked="" type="checkbox"/> 24A110BL	Alternator - 110 Amp	<input checked="" type="checkbox"/> LCS4	
<input type="checkbox"/> 24A150BL	Alternator - 150 Amp	<input checked="" type="checkbox"/> DAS-W	Driver alert support warning
<input type="checkbox"/> 24A180BL	Alternator - 180 Amp	<input type="checkbox"/> RSENS-W	Rain sensor to activate wipers
<input type="checkbox"/> 24AL110B	Alternator - 110 Amp	<input checked="" type="checkbox"/> CU-ECC	Climate controlled air conditioning
<input type="checkbox"/> 24AL150B	Alternator - 150 Amp (Eu5)	<input type="checkbox"/> CU-ECC2	Electronically Controlled Air Conditioning with Air Quality Sensor & Carbon Filter
<input type="checkbox"/> PRIM-EL	Pump Prime - Electrical	<input type="checkbox"/> CU-MCC	Manual controlled air conditioning
<input checked="" type="checkbox"/> PRIM-MAN	Pump Prime - Manual	<input checked="" type="checkbox"/> IGT-BUT	Ignition Type - Push Button
<input type="checkbox"/> FUEQ-EH	Fuel line heater equip.	<input checked="" type="checkbox"/> IMMOBIL	Engine Immobiliser
<input type="checkbox"/> AF-E	Auxiliary fuel filter, electrically heated	<input type="checkbox"/> ALARM-E	Anti-theft alarm (cab & body/trailer)
<input type="checkbox"/> AF-R	Recirculation heated fuel filter	<input type="checkbox"/> ISUNS-BS	Interior Side Sunvisor - Both Doors
<input checked="" type="checkbox"/> FUEFE2LW	Dual fuel filter, engine mounted with water separator-large	<input checked="" type="checkbox"/> ISUNS-DS	Interior Side Sunvisor - Driver's Door
<input checked="" type="checkbox"/> FUEFE2SW	Dual fuel filter, engine mounted with water separator-small	<input type="checkbox"/> ISUNF-B	Interior front sunvisor - standard
<input type="checkbox"/> EST-AID	Engine starting aid	<input type="checkbox"/> ISUNF-MD	Interior front sunvisor - with mirror (driver's side)
<input type="checkbox"/> 220EBH15	220V/1.5kw engine block heater	<input type="checkbox"/> ISUNF-RE	Windscreen Interior Sunvisor - Electric
<input type="checkbox"/> PTER-100	PTO Engine Rear Mounted with Flange DIN100/ISO7646	<input checked="" type="checkbox"/> ISUNF-RM	Windscreen Interior Sunvisor - Manual
<input type="checkbox"/> PTER-DIN	Power Take Off / splined shaft groove (female) DIN5462.	<input type="checkbox"/> ADFS	2 Din Slots in Front Shelf
<input type="checkbox"/> PTER1400	Rear engine mounted power-take-off with flange SAE 1410	<input type="checkbox"/> BUPALARM	Reverse alarm
<input type="checkbox"/> HPE-F101	F1-101 Hydraulic pump rear engine mounted	<input type="checkbox"/> RTOLL-PK	Road toll prep kit
<input type="checkbox"/> HPE-F41	F1-41 Hydraulic pump rear engine mounted	<input type="checkbox"/> LOADIND	Load indicator, electronic controlled suspension (SUSPL-EC)
<input type="checkbox"/> HPE-F51	F1-51 Hydraulic pump rear engine mounted	<input type="checkbox"/> REMC-MF	Multifunction Wireless Remote Control
<input type="checkbox"/> HPE-F61	F1-61 Hydraulic pump rear engine mounted	<input type="checkbox"/> FIREX3FR	Fire extinguisher, 3 kg, French decal
<input type="checkbox"/> HPE-F81	F1-81 Hydraulic pump rear engine mounted	<input type="checkbox"/> FIREXT2F	Fire extinguisher, 2 kg, French decal
<input type="checkbox"/> HPE-T53	F2-53/53 twin flow hyd pump rear engine mounted	<input type="checkbox"/> FIREXT2G	
<input type="checkbox"/> HPE-T70	F2-70/53 twin flow hyd pump rear engine mounted	<input type="checkbox"/> FIREXT3D	Fire extinguisher, 3 kg, Danish decal
<input type="checkbox"/> HPE-V45	V1-45 variable pump rear engine mounted	<input type="checkbox"/> FIREXT3F	Fire extinguisher, 3 kg, Finnish decal
<input type="checkbox"/> HPE-V75	V1-75 variable pump rear engine mounted	<input type="checkbox"/> FIREXT3N	Fire extinguisher, 3 kg, Norwegian decal
<input type="checkbox"/> PTPT-D	PTO DIN - Powertronic	<input type="checkbox"/> FIREXT3P	Fire extinguisher, 3kg, Portuguese decal
<input type="checkbox"/> PTPT-F	PTO Flange Connection - Powertronic	<input type="checkbox"/> FIREXT3S	3kg fire extinguisher
<input type="checkbox"/> PTR-D	Low speed PTO with DIN connection	<input type="checkbox"/> WARNVEST	Warning vest
<input type="checkbox"/> PTR-DH	High speed PTO with DIN connection	<input checked="" type="checkbox"/> WARNTRI2	2 warning triangles
<input type="checkbox"/> PTR-DM	Medium speed PTO with DIN connection	<input type="checkbox"/> AIDKIT	First aid kit
<input type="checkbox"/> PTR-F	PTO Flange Connection - 100% speed		
<input type="checkbox"/> PTR-FH	High speed PTO with flange connection		
<input type="checkbox"/> PTR-FL	Low speed PTO with flange connection		
<input type="checkbox"/> PTRD-D	PTO with 2 DIN connections rear + 1 DIN connection front		
<input type="checkbox"/> PTRD-D1	PTO with 1 DIN + 1 flange connection rear + 1 DIN connection front		

Standard Equipment Optional Equipment

For more detailed information about cab and powertrain equipment, please refer to separate specification sheets.

For all possible options and combinations of options please consult your Volvo sales contact who can create a specification to match your requirements using the Volvo Sales Support system (VSS).

The factory reserves the right to modify design and change equipment without previous notification. The specification can vary from country to country.

MODEL RANGE

FM13 6x4 Rigid Air Suspension FM 64R 3A

<input type="checkbox"/>	AIDKIT1B	First aid kit-German market demands	<input checked="" type="checkbox"/>	RH-EE	Sky Window - Emergency Exit Roof Glass (tinted)
<input type="checkbox"/>	WARNLAMP	Portable warning lamp	<input type="checkbox"/>	RH-ER	Roof Hatch - Electric (Metal Emergency Exit)
<input type="checkbox"/>	LAMP-IN	Inspection lamp	<input type="checkbox"/>	RH-ETR	Roof Hatch - Electric (Tinted Glass & Rear Opening)
<input type="checkbox"/>	BULBKIT	Bulb and fuse kit	<input type="checkbox"/>	RH-MTR	Roof Hatch - Manual (Tinted Glass & Rear Opening)
<input type="checkbox"/>	WRITEPAD	Storable steering wheel fit clip board	<input type="checkbox"/>	GLAS-UNT	Clear window glass
<input checked="" type="checkbox"/>	DST-CF1	Driver seat comfort suspended	<input type="checkbox"/>	SWIND-BS	Cab side window-both sides
<input type="checkbox"/>	DST-CF4	Fully adjustable driver's comfort seat	<input type="checkbox"/>	SWIND-PS	Cab Passenger Side Aux. Window
		Air suspension	<input type="checkbox"/>	AWIND-RF	Cab Rear Window- Fitted
<input type="checkbox"/>	DST-CF5	Fully adjustable driver's comfort seat	<input type="checkbox"/>	VANMIR	Vanity Mirror
		Air suspension, heated, integrated safety belt	<input type="checkbox"/>	AS-FUS	Auxiliary Shelf - Front Upper Storage
<input type="checkbox"/>	DST-CF6	Fully adjustable driver's comfort seat	<input type="checkbox"/>	INFOT-PK	LCD screen mount - 6kgs max
		Air suspension, integrated safety belt			
<input type="checkbox"/>	DST-STD2	Driver seat standard, suspended	Cab exterior		
<input type="checkbox"/>	SBD-RED	Red safety belts, pass. & driver seats	<input type="checkbox"/>	EXTL-BA2	Standard Exterior Trim Level 2
<input type="checkbox"/>	SBPRE-DS	Drivers seat belt pretensioner	<input checked="" type="checkbox"/>	EXTL-BAS	Standard exterior trim level
<input type="checkbox"/>	PST-BAS1	Basic passenger's seat	<input checked="" type="checkbox"/>	DGLAS-H	Hardened Door Glass
<input type="checkbox"/>	PST-CF4	Fully adjustable passengers comfort seat	<input type="checkbox"/>	DGLAS-L	Laminated Door Glass
		Air suspension, integrated safety belt	<input checked="" type="checkbox"/>	BUMP-B	Bumper - Plastic
<input type="checkbox"/>	PST-CF5	Fully adjustable passenger comfort seat	<input type="checkbox"/>	BUMP-B2	Bumper - Steel
		Air suspension, heated, safety belt	<input type="checkbox"/>	BUMP-SP	Bumper spoiler
<input checked="" type="checkbox"/>	PST-STD2	Passenger Seat Basic 2 Armrests	<input type="checkbox"/>	GUARD-EH	Guard plate for cooling pipes and oil sump
<input type="checkbox"/>	PST-STD4	Passenger Seat Basic 2 Armrests Susp	<input checked="" type="checkbox"/>	BUGNET	Insect Net in Front of Radiator
<input type="checkbox"/>	SBPRE-PS	Passenger seatbelt pretensioner	<input type="checkbox"/>	CTILT-P-E	Electrical cab tilt pump
<input type="checkbox"/>	ARMRE-BB	Armrests both sides - driver's & passenger's seat	<input checked="" type="checkbox"/>	CTILT-P-M	Manual cab tilt pump
<input type="checkbox"/>	ARMRE-DB	Armrests both sides - driver's seat	<input type="checkbox"/>	FCABS-A	Front Cab Suspension - Air Bellows
<input type="checkbox"/>	ARMRE-PB	Armrests both sides - passenger's seat	<input checked="" type="checkbox"/>	FCABS-M	Front Cab Suspension - Mechanical Spring
<input type="checkbox"/>	ARU-BAS	Seat armrest upholstery - basic	<input type="checkbox"/>	RCABS-A	Rear Cab Suspension - Air Bellows
<input type="checkbox"/>	ARU-LEA	Seat armrest upholstery - leather	<input checked="" type="checkbox"/>	RCABS-M	Rear Cab Suspension - Mechanical Spring
<input checked="" type="checkbox"/>	FMAT-RUB	Floor Mats - Rubber	<input type="checkbox"/>	MIRCFPCS	Electrically Heated & Operated Convex Glass Mirrors with Front Monitoring Camera on Passenger Side
<input type="checkbox"/>	FMAT-TX2	Floor Mats - Textile & Rubber	<input type="checkbox"/>	MIRCFCPX	Electrically Heated & Operated Convex Glass Mirrors with Front Monitoring Camera on Passenger Side
<input type="checkbox"/>	LBK70	Lower Bunk 700mm Wide	<input type="checkbox"/>	MIRC MCP	Camera Monitor System & Blind Spot Camera - Without Exterior Mirrors
<input type="checkbox"/>	MATL-FI	Spring Mattress Lower Bunk - Firm (100kg +)	<input type="checkbox"/>	MIRCMS	Camera Monitor System - Without Exterior Mirrors
<input type="checkbox"/>	MATL-SF	Mattress lower bunk - semi firm	<input checked="" type="checkbox"/>	MIRC COMF	Electrically heated and operated exterior mirrors with wide angle mirrors on both sides and close view mirror on passenger side.
<input type="checkbox"/>	OLMAT-BA	Mattress overlay - basic	<input type="checkbox"/>	MIRC COMFX	Electrically Heated & Operated Convex Glass Mirrors
<input type="checkbox"/>	OLMAT-PR	Mattress overlay - premium	<input checked="" type="checkbox"/>	AMIR-F20	Close view mirror
<input type="checkbox"/>	TBK60F	Top bunk 600mm wide, foldable	<input type="checkbox"/>	SUNV-H	Exterior Sunvisor
<input type="checkbox"/>	TBK70F	Top Bunk 700mm Wide - Foldable	<input type="checkbox"/>	AD-ROOF	Aero-dynamic roof mounted deflector
<input type="checkbox"/>	PH-CAB2	Cab parking heater 2kw	<input type="checkbox"/>	AD-SIDES	Aero-dynamic cab side deflectors
<input type="checkbox"/>	PH-ENGCA	Cab and engine parking heater	<input type="checkbox"/>	HL-BASIC	Standard head lamps
<input type="checkbox"/>	PH-SS	Cab parking heater short stop	<input checked="" type="checkbox"/>	HL-LED	LED Headlights
<input type="checkbox"/>	SLCP-BAS	Sleeper Control Panel - Standard	<input type="checkbox"/>	HBDA-A	Automatic High Beam De-Activation
<input type="checkbox"/>	ETSB-F	Engine Tunnel Storage Box	<input checked="" type="checkbox"/>	HL-CLEAN	Head lamp cleaning system
<input type="checkbox"/>	ETSB-FR	Storage Box - Engine Tunnel & Rear Cab Wall	<input type="checkbox"/>	HLP-ST	Headlight Protection - Steel
<input type="checkbox"/>	ETSB-FRS	Engine Tunnel Storage Box - Front, Rear & Side	<input type="checkbox"/>	HL-ADJ	Headlight Adjustment - Manual
<input type="checkbox"/>	ETSB-FS	Engine Tunnel Storage Box - Front & Side	<input checked="" type="checkbox"/>	DRL-LED	V-shaped LED Daytime Running Light
<input type="checkbox"/>	ETSB-R	Rear Cab Wall Storage	<input type="checkbox"/>	DRIVL2	Integrated driving lamps
<input type="checkbox"/>	ETSB-RS	Engine Tunnel Storage Box - Rear & Side	<input checked="" type="checkbox"/>	UDRIVL	Without Integrated Driving Lights
<input type="checkbox"/>	ETSB-S	Engine Tunnel Storage Box & Right Side Space for Binder	<input checked="" type="checkbox"/>	FOGL-WC	Integrated fog lamps
<input type="checkbox"/>	RUS-BAS	Rear Upper Cab Storage - 154 Litres for Sleeper/Globetrotter & 60 Litres for Day Cab	<input type="checkbox"/>	CL-STAT	Corner light-static
<input type="checkbox"/>	RUS-HIG	Rear Upper Cab Storage - 245 Litres	<input type="checkbox"/>	ASL-RF2	Spotlights Inside Globetrotter Sign Box
<input type="checkbox"/>	REF-ICPK	Refrigerator Preparation Kit on Engine Tunnel	<input type="checkbox"/>	IDLAMP-A	Identification Lamps - Amber
<input type="checkbox"/>	REFR-RUS	28 Litre Refrigerator in Upper Rear Storage	<input type="checkbox"/>	IDLAMP-W	Identification Lamps - white
<input type="checkbox"/>	MICRO-PK	Preparation Kit for Microwave			
<input type="checkbox"/>	BOTH-D	Bottle Holder in Driving Area			
<input type="checkbox"/>	COFMA-PK	Coffee maker prep kit			
<input checked="" type="checkbox"/>	INLI-BAS	Interior night lights			
<input type="checkbox"/>	INLI-NL	Interior White & Red (night) Light			
<input type="checkbox"/>	INLI-NLD	Interior light including night light and dimmer function			
<input type="checkbox"/>	ARL-FLEX	Flexible Reading Lamp (Snake Light)			

Standard Equipment

Optional Equipment

For more detailed information about cab and powertrain equipment, please refer to separate specification sheets.

For all possible options and combinations of options please consult your Volvo sales contact who can create a specification to match your requirements using the Volvo Sales Support system (VSS).

The factory reserves the right to modify design and change equipment without previous notification. The specification can vary from country to country.

MODEL RANGE

FM13 6x4 Rigid Air Suspension FM 64R 3A

- | | |
|--|--|
| <ul style="list-style-type: none"> <input type="checkbox"/> IDLMP5W Switch in cab for identification lamps <input type="checkbox"/> BEACOA2F 2 amber rotating lights- front of roof <input type="checkbox"/> BEACOA2R 2 amber rotating lights- rear of roof <input type="checkbox"/> BEACON-P Beacon Light Wire Preparation <input type="checkbox"/> BEACONA4 4 amber rotating lights <input type="checkbox"/> CABPT-R1 1 cab roof pass through on driver's side <input checked="" type="checkbox"/> CABPT-R2 2 cab roof pass throughs, 1 on each side <input type="checkbox"/> SPOTP-F Aux spotlight preparation, 280W maximum <input type="checkbox"/> SPOTP-R Spot light preparation on roof, max 280W <input type="checkbox"/> SPOTP-RF Spot light preparation in front and on roof, max 280W <input type="checkbox"/> ROS-IL Illuminated roof sign <input type="checkbox"/> ROS-IL2 <input type="checkbox"/> ROS-ILP Illuminated Cab Sign Prep Kit <input type="checkbox"/> CSGN-GTR Globetrotter decal <input checked="" type="checkbox"/> HORN-F1S Single Electric Jericho Air Horn (Behind Grill) <input type="checkbox"/> HORN-R2S Chromed air horns, two roof mounted <input type="checkbox"/> ANT-CBR Antenna for CB Radio (Single Antenna) <input type="checkbox"/> ACCB-R-AP Accessory bracket-forward, mid & rearward roof mounted <input type="checkbox"/> ACCB-R-F Accessory bracket-forward roof mounted <input type="checkbox"/> ACCB-R-FM Accessory bracket-forward & mid roof mounted <input type="checkbox"/> ACCB-R-FR Accessory bracket-forward & rearward roof mounted <input type="checkbox"/> ACCB-R-M Accessory bracket-mid roof mounted <input type="checkbox"/> ACCB-R-R Accessory bracket-rearward roof mounted <input type="checkbox"/> ACCB-R-RM Accessory bracket-rearward & mid roof mounted <input type="checkbox"/> REFS-CW Reflecting stripes mounted on cab - white <input type="checkbox"/> REFS-TW Reflecting stripes transport mounted on cab - white <input type="checkbox"/> REFS-TY Reflecting stripes transport mounted on cab - yellow <p>Superstructure</p> <ul style="list-style-type: none"> <input type="checkbox"/> CROSSRE Cross frame reinforcement <input type="checkbox"/> SRWL-2RW 2 Rear Chassis Mounted Working Lamps - White <input type="checkbox"/> SRWL-PK Wiring Prep for Chassis Mounted Reverse/Working Lamps - 3 Position Switch <input type="checkbox"/> SWL-2FW 2 Side Working Lamps - White (Forward Facing) <input type="checkbox"/> SWL-2RW 2 Side Working Lamps - White (Rearward Facing) <input type="checkbox"/> SWL-4W 4 Side Working Lamps - White <input type="checkbox"/> SWL-PK Wiring Prep for Chassis Mounted Working Lamps - 2 Position Switch <input type="checkbox"/> WL-CHPK Chassis Mounted Working Light Prep Kit <input type="checkbox"/> WLC-H2W 2 LED work lamps - High Mounted with White Lens. <input type="checkbox"/> WLC-PKH Prep Kit for High Mounted Work Lamps <input type="checkbox"/> WLC-PKL Prep Kit for Low Mounted Work Lamps <input type="checkbox"/> WLC-PKLH Prep Kit for Low and High Mounted Work Lamps <input type="checkbox"/> ECBB-BAS B/B Elect. Centre without B/B Module <input type="checkbox"/> ECBB-HIG Body Builder Module - Cab Module (14 High/4 Low) <input checked="" type="checkbox"/> ECBB-MED Body Builder Module - Cab Module (7 High/4 Low) <input type="checkbox"/> BBCHAS1 Body Builder Chassis Electrical Interface - 1 x 7 Pin Connector <input type="checkbox"/> BBCHAS3 Body Builder Chassis Electrical Interface - 3 x 7 Pin Connectors <input type="checkbox"/> BEPR-T2 Body Builder electrical prep. for tipper with remote control <input type="checkbox"/> EXSTER External Steering via Body Builder's Module <input checked="" type="checkbox"/> TD-LED LED trailer detection sensor <input type="checkbox"/> FRFS-BS Frame Rail Free Space - Both Sides <input type="checkbox"/> FBA-BTF Front body attachment- flexible <input type="checkbox"/> FBA-BTSF Front body attachment-semi flexible <input type="checkbox"/> HBA-FSFB Holes for Body Attachments, Flexible & Semi Flexible <input type="checkbox"/> HBA-SB Holes for Body Attachments <input type="checkbox"/> RBA-T2 Rear body attachment type 2-divided <input type="checkbox"/> CRANEPK1 Crane interface for capacity up to 10t <input type="checkbox"/> CRANEPK2 Crane interface for capacity up to 20t <input type="checkbox"/> CRANEPK4 Crane interface for capacity up to 40t <input type="checkbox"/> AUXL-SPK Aux. lamps snow plough prep kit <p> <input checked="" type="checkbox"/> Standard Equipment <input type="checkbox"/> Optional Equipment </p> | <ul style="list-style-type: none"> <input type="checkbox"/> TAILPRE2 Taillift preparation kit for wireless remote <input type="checkbox"/> TAILPREP Taillift preparation kit <input type="checkbox"/> AESW2 2 Flexible Switches (AUX1 and AUX2). <input type="checkbox"/> AESW2PK 2 Flexible Switches (AUX1 & AUX2) + Additional 4 Flexible Switches <input type="checkbox"/> AUXSW-4 Wiring Prep. for 4 Extra Bodybuilder Switches (switches not included) <p>Delivery services</p> <ul style="list-style-type: none"> <input checked="" type="checkbox"/> TGW-4GWL Telematics Gateway with 4G/LTE & WLAN <input type="checkbox"/> TGW-PK Telematics gateway prep kit <input type="checkbox"/> FMS-PK Fleet management system gateway <input type="checkbox"/> DRUT1 "My Truck" Smartphone App. 1 Year Prepaid <input type="checkbox"/> DRUT2 "My Truck" Smartphone App. 2 Year Prepaid <input type="checkbox"/> DRUT3 "My Truck" Smartphone App. 3 Year Prepaid <input type="checkbox"/> DRUT4 "My Truck" Smartphone App. 4 Year Prepaid <input type="checkbox"/> DRUT5 "My Truck" Smartphone App. 5 Year Prepaid <input checked="" type="checkbox"/> TSRS Traffic Sign Recognition System (ISA Compliant) <input type="checkbox"/> TSRS2 Traffic Sign Recognition System |
|--|--|

For more detailed information about cab and powertrain equipment, please refer to separate specification sheets.

For all possible options and combinations of options please consult your Volvo sales contact who can create a specification to match your requirements using the Volvo Sales Support system (VSS).

The factory reserves the right to modify design and change equipment without previous notification. The specification can vary from country to country.

MODEL RANGE

FM13 6x4 Rigid Air Suspension FM 64R 3A

Volvo Trucks. Driving Progress