

MODEL RANGE

FM 62 Rigid Tag Electric FM 62R TE

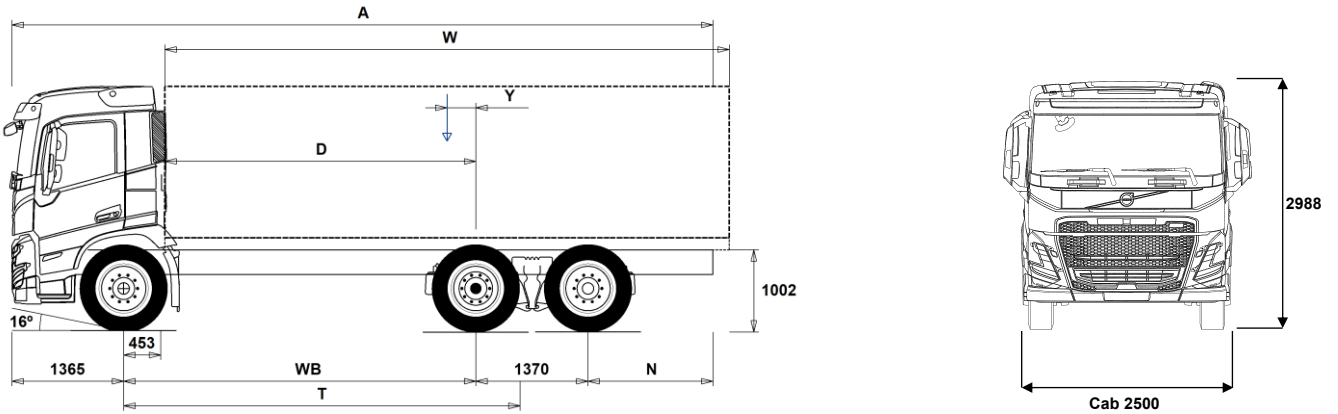

Chassis Dimensions [mm]

| WB Wheelbase | 3900 | 4100 | 4300 | 4600 | 4900 | 5200 | 5600 | 6000 |
|--|------|-------|------|------|-------|-------|-------|-------|
| A Overall Chassis Length | 9960 | 10160 | 9410 | 9860 | 10310 | 10810 | 11410 | 12060 |
| D Center of rear axle to front of body | 3397 | 3597 | 3797 | 4097 | 4397 | 4697 | 5097 | 5497 |
| N Rear Overhang (Min.) | 825 | 825 | 825 | 825 | 825 | 1225 | 1225 | 1225 |
| N Rear Overhang (Max.) | 3325 | 3325 | 2375 | 2525 | 2675 | 2875 | 3075 | 3325 |
| T Theoretical Wheelbase | 4441 | 4641 | 4841 | 5141 | 5441 | 5741 | 6141 | 6541 |
| Y Center of Gravity for Payload (Min.) | 113 | 121 | 113 | 127 | 137 | 152 | 169 | 184 |
| Y Center of Gravity for Payload (Max.) | 113 | 121 | 113 | 127 | 137 | 152 | 169 | 184 |
| W Body Length (Min.) | 6575 | 6958 | 7375 | 7947 | 8433 | 8913 | 9553 | 10099 |
| W Body Length (Max.) | 6575 | 6958 | 7375 | 7947 | 8433 | 8913 | 9553 | 10099 |

Chassis Weights [kg]

| | | | | | | | | |
|--|-------|-------|-------|-------|-------|-------|-------|-------|
| Front Axle | 5485 | 5565 | 5695 | 5785 | 5880 | 5955 | 6045 | 6130 |
| Rear Bogie | 4350 | 4285 | 4140 | 4080 | 4035 | 3995 | 3945 | 3925 |
| Kerb Weight | 9835 | 9850 | 9835 | 9865 | 9915 | 9950 | 9990 | 10055 |
| Payload (including body, driver, fuel, etc.) | 17165 | 17150 | 17165 | 17135 | 17085 | 17050 | 17010 | 16945 |

Turning Diameter [mm]

| | | | | | | | | |
|--------------------------------------|-------|-------|-------|-------|-------|-------|-------|-------|
| Turning Circle Diameter Kerb to Kerb | 16300 | 17000 | 17600 | 18600 | 19500 | 20500 | 21800 | 23100 |
| Turning Circle Diameter Wall to Wall | 17700 | 18300 | 19000 | 19900 | 20900 | 21900 | 23100 | 24400 |

Plated Weights [kg]

| | Design |
|--------------------------|--------|
| Gross Vehicle Weight | 27000 |
| Gross Combination Weight | 32000 |
| Front Axle | 8000 |
| Rear Bogie | 19000 |

Important Notes

Chassis Dimensions

Cab Height: +374 mm for CAB-HSLP, -204 mm for CAB-LDAY, -204 mm for CAB-LSLP, +4 mm for CAB-SLP.

Front Axle to Back of Cab: +422 mm for CAB-HSLP and CAB-LSLP and CAB-SLP.

D-measure includes a front clearance of 50 mm and for rigid trucks also a subframe of 100 mm.

Height can vary ± 20 mm for leaf and ± 10 mm for air suspension.

All dimensions are for unladen chassis and any tag axles down. Chassis height used: CHH-MED.

Height change when chassis height CHH-HIGH: 0 mm.

Weight and dimensions are based upon the following tyres:

| | |
|-----------------------------|-------------|
| Front Axle Tyres: | 315/80R22.5 |
| Drive Axle Tyres: | 315/80R22.5 |
| Trailing/Pusher Axle Tyres: | 315/80R22.5 |

Chassis weight includes oil, water, AdBlue, 0 litres fuel and without driver. Kerb weight can vary ± 3%.

Turning diameters are theoretically calculated. Tag axle used: TA-FIXED.

Legal weights can differ from country to country.

For more detailed weight information, including optional equipment weights, ask your Volvo sales contact to enter your specification into the Volvo Weight Information system (WIS).

Do NOT use this drawing for bodybuilding. Refer to Volvo Bodybuilder Instructions and chassis assembly drawing FM62RTE.

MODEL RANGE

FM 62 Rigid Tag Electric FM 62R TE

Transport operation

- **RC-SMOOT** Smooth road conditions: at least 95% of the driven distance is on well-maintained or less maintained surfaced roads. Driving may occur on poorly maintained surfaced roads, hard-packed sand, or gravel surfaces of good or bad quality.
- **GARB-PRE** Refuse vehicle preparation
- **TIPP-PRE** Tipper vehicle preparation
- **UNIFORM** Basic platform vehicle

Core components

- **CHH-HIGH** Chassis height high - approx. 1000 mm above ground level
- **CHH-MED** Chassis height medium - approx. 900 mm above ground level
- **TA-HYSB2** Electro-hydraulically steered single-wheel tag axle with steering lockout at 38 km/h
- **TAG-FIXD** Fixed twin-wheel tag axle
- **TAG-FIXS** Fixed single-wheel tag axle
- **RADT-GR** Rear air suspension - two axles, one pusher, one tag
- **FME-DAY6** FM Electric day cab
- **FME-HSL6** FM Electric Globetrotter, high sleeper cab
- **FME-LDA6** FM Electric low day cab
- **FME-LSL6** FM Electric low sleeper cab
- **FME-SLP6** FM Electric sleeper cab
- **ESS270K** Total installed nominal energy 270 kWh (3 batteries)
- **ESS360K** Total installed nominal energy 360 kWh (4 batteries)
- **ESS450K** Total installed nominal energy 450 kWh (5 batteries)
- **ESS540K** Total installed nominal energy 540 kWh (6 batteries)
- **EPT2412** Electric 12-speed propulsion gearbox, 2400 Nm
- **NEM2** 2 electrical motors
- **NEM3** 3 electrical motors
- **RSS1344C** Rear single reduction solo axle - axle load 13 tonnes, GCW 44 tonnes, version C
- **RSS1344F** Rear single reduction solo axle - axle load 13 tonnes, GCW 44 tonnes, version F
- **RSS1352B** Rear single reduction solo axle - axle load 13 tonnes, GCW 52 tonnes, version B
- **RSS1370C** Rear single reduction solo axle - axle load 13 tonnes, GCW 70 tonnes, version C

Packages

- **INFOHIGH** Information package, high (with side display)
- **DRIV-EXT** Driver convenience package, Extended
- **DRIV-SEL** Driver convenience package, Selected
- **1LIVFM-E** Living package, 1 bed (FM Electric)
- **2LIVFM-E** Living package, 2 beds (FM Electric)
- **SAFE-EXT** Active Safety package Extended
 - Volvo Dynamic Steering with personal setting and Stability Assist
 - Adaptive cruise control with forward Collision Warning with Emergency Brake
 - Pilot Assist, active continuous lane keeping
 - Automatic Trailer Brake Activation, Stretch Brake
- **SAFE-SEL** Active Safety package Selected, contains
 - Volvo Dynamic Steering with personal setting and Stability Assist
 - Personal setting and Stability Assist
 - Forward Collision Warning with Emergency Brake
 - Lane Keeping Assist
- **RANGOP3** Range Optimization package, 3-year prepaid subscription
- **RANGOP4** Range Optimization package, 4-year prepaid subscription
- **RANGOP5** Range Optimization package, 5-year prepaid subscription

Chassis

- **FST-AIR** Front air suspension
- **FSLs-BAS** Basic levelling stroke in front air suspension (high ground clearance under front axle member)
- **FSLs-HI** High-range levelling stroke in front air susp. (reduced ground clearance under front axle member)

- **FAL10.0** Front axle load 10.0 tonnes
- **FAL8.0** Front axle load 8.0 tonnes
- **FAL8.5** Front axle load 8.5 tonnes
- **FAL9.0** Front axle load 9.0 tonnes
- **FSTAB2** Front anti-roll bar, high stiffness
- **FSTAB3** Front anti-roll bar, extra-high stiffness
- **RAL19** Rear axles load 19 tonnes
- **RAL20.5** Rear axles load 20.5 tonnes
- **RAL22.5** Rear axles load 22.5 tonnes
- **RAL23** Rear axles load 23 tonnes
- **RSTAB2** Rear anti-roll bar, high stiffness
- **RSTAB3** Rear anti-roll bar, extra-high stiffness
- **RALIM10** First rear drive axle load limiter, 10 tonnes
- **RALIM10S** First rear driving axle load limiter, 10.5 tonnes (speed controlled)
- **RALIM11S** First rear driving axle load limiter, 11.5 tonnes (speed controlled)
- **RALIM15** First rear driving axle load limiter, 15 tonnes
- **RALIM9S** First rear driving axle load limiter, 9.5 tonnes (speed controlled)
- **ASF-DL1** Air suspension with one ride height
- **ASF-DL3** Air suspension with three ride heights
- **ASF-DLL** Air suspension with speed-dependent lowering of ride height for lower air resistance
- **ACTST-TO** Volvo Dynamic Steering
- **ASFE-BAS** Volvo Dynamic Steering, basic
- **ASFE-OG** Volvo Dynamic Steering with Stability Assist
- **ASFE-PO** Volvo Dynamic Steering with Personal Settings and Stability Assist
- **ASFE-PS** Volvo Dynamic Steering with Personal Settings
- **RST-AIR** Rear air springs
- **RST-AIR4** Rear air springs (extra stiff)
- **RST-AIR6** Rear air springs for hot climates
- **FRAME300** Frame rail section external height 300 mm
- **FST8080** Frame thickness - web 8.0 mm / flange 8.0 mm
- **FIL-EEEB** Frame inner liner from end of engine to end of bogie
- **FIL-EEEF** Frame inner liner from end of engine to end of frame
- **FIL-FBEB** Frame inner liner from front of bogie to end of bogie
- **FIL-TXEB** Frame inner liner from transmission cross member to end of bogie
- **FIL-TXEF** Frame inner liner from transmission cross member to end of frame
- **BATTAMP** Battery voltmeter and ammeter
- **BATTIND** Battery voltmeter, ammeter and battery status gauge with visual alerts
- **WHC-FIX2** Two non-collapsible wheel chocks
- **WHC-FOL2** Two collapsible wheel chocks
- **WHCP-M** Wheel chock holder in the middle part of the vehicle
- **WHCP-R** Wheel chock holder in the rear part of the vehicle
- **WHCP-T** Wheel chock holder by-packed in cab outer luggage compartment
- **SUP-BAS** Standard side underrun protection, aluminium
- **CHAIN-S** Snow chains
- **HOOK-SC** Snow chain hooks
- **TOWF-NO1** One front towing device
- **TOWF-NO2** Two front towing devices
- **TOWMBRH** Towing member, high-mounted in centre of frame
- **TOWMBRL1** Towing member, low-mounted under frame
- **TOWMBRL2** Towing member, low and forward-mounted under frame
- **TOWMBRM** Towing member, medium-mounted in line with lower frame flange
- **RFEC-L** Tapered lower rear frame end (for centre axle drawbar)
- **RFEC-S** Straight-cut rear frame end
- **RFEC-U** Upper corner cut on rear frame end (for e.g. tipper, refuse and hook lift applications)

■ Standard Equipment □ Optional Equipment

For more detailed information about cab and powertrain equipment, please refer to separate specification sheets.

For all possible options and combinations of options please consult your Volvo sales contact who can create a specification to match your requirements using the Volvo Sales Support system (VSS).

The factory reserves the right to modify design and change equipment without previous notification. The specification can vary from country to country.

MODEL RANGE

FM 62 Rigid Tag Electric FM 62R TE

- **C-RI4040** Coupling Ringfeder 4040A G-150
- **C-RI4045** Coupling Ringfeder 4045A G-150
- **C-RI5050** Coupling Ringfeder 5050A G-150
- **C-RO50** Coupling Rockinger 50 mm
- **C-VBG520** Coupling VBG 5200D
- **C-VBG795** Coupling VBG 795V

- **TOWR-ONE** Brace that can be used for towing in specific situations. The brace is mounted on the end cross member, and if the end cross member is thinner than 8 mm, it will be reinforced. The brace includes a lockable pin and is dimensioned for a 3-tonne centre-axle trailer or a 10-tonne articulated drawbar trailer. It may only be used for short-distance, on-site transport in confined areas and at speeds of a maximum of 30 km/h.

- **TREL-PK** Trailer electrical preparation kit (chassis/cab wiring)
- **TREL14** 14-pin trailer connection
- **TREL15** 15-pin trailer connection (ADR certified)
- **TREL7-7** 2x7-pin trailer connection (ISO 24N+24S, non-ADR)
- **TBC-EC** Trailer brake connection, European Community
- **TRBR-HCR** Reduced-pressure, hand-controlled trailer brake check (4 bar)
- **TRBR-STA** Stationary trailer brake check
- **TRB-STRE** Stretch brake, trailer brake activation at low speeds to avoid jack-knifing and improve stability
- **RFEND-B** Rear 3-piece mudguards (anti-spray) on all rear axles
- **RFH-BAS** Basic mudguard installation height on 2nd front axle and rear axles
- **RFH-HIG** High mudguard installation height on 2nd front axle and rear axles
- **RFH-LOW** Low mudguard installation height on 2nd front axle and rear axles
- **AUXATNK** Extra air tank for air suspension
- **RESTS-W** Reflective white stripes on chassis side: underrun protection, tool box, between mudguards, overhang
- **REST-RUP** Reflective red stripe on rear underrun protection
- **BLIGHT-E** Flashing brake lights will automatically activate in emergency braking. The flashing frequency is 4 Hz and emergency braking is detected if speed exceeds 50 km/h and retardation is 4 m/s² or more. The function deactivates when retardation is less than 2.5 m/s².

Rims and tyres

- **RT-AL** Brushed aluminium rims with standard holes (long stud fixing) on all axles
- **RT-AL1** LVL ONE® smooth and glossy aluminium rims with standard holes (long stud fixing) on all axles
- **RT-AL1DU** LVL ONE® smooth and glossy aluminium rims with countersunk holes (short stud fixing) on all axles
- **RT-ALDP** Dura-Bright® polished aluminium rims with standard holes (long stud fixing) on all axles
- **RT-ALDPP** Dura-Bright® polished aluminium rims with countersunk holes (short stud fixing) on all axles
- **RT-ALDU** Brushed aluminium rims with countersunk holes (short stud fixing) on all axles
- **RT-ALP** Polished aluminium rims with standard holes (long stud fixing) on all axles
- **RT-ALPDU** Polished aluminium rims with countersunk holes (short stud fixing) on all axles
- **SPWT-D** Spare driving wheel
- **SPWT-F** Spare front wheel
- **SWCP-T** Spare wheel transport-mounted on top of frame
- **SWCP-TP** Spare wheel and carrier transport-mounted on top of frame
- **JACK-12T** Hydraulic jack, 12 tonnes. Low manual pumping force facilitates use in uncomfortable positions. Has a release valve, which permits safe, easy and precise control over rate of lowering and a filter in the oil reservoir gives protection from contamination.
Height 180-315 mm, weight 7.0 kg
- **JACK-15T** Hydraulic jack, 15 tonnes. Low manual pumping force facilitates use in uncomfortable positions. Has a release valve,

- **JACK-20T** Hydraulic jack, 20 tonnes. Low manual pumping force facilitates use in uncomfortable positions. Has a release valve, which permits safe, easy and precise control over rate of lowering and a filter in the oil reservoir gives protection from contamination.
Height 225-438 mm, weight 9.4 kg
- **TOOLKIT** This kit consists of a tool bag (case) including the following tools:
 - Combination screwdriver.
 - 1 screwdriver handle
 - 1 blade, Philips/flat blade
 - 1 blade, Torx T10/Torx T20
 - 1 blade, Torx T25/Torx T27
 - 1 blade, Torx T30/Torx T40
 - Socket wrench.
 - Adjustable pliers.
 - Allen key.
 - Adjustable spanner.
 - Hammer.
- **INFLAHOS** Tyre inflation hose 18 m. The air is supplied by a chassis-mounted pneumatic outlet (must be ordered separately).
- **GAUGE-TP** Tyre pressure gauge

Powertrain equipment

- **DRM-B** I-Shift drive mode Standard
- **DRM-BE** I-Shift drive modes Range, Standard and Performance
- **EP400A** Electrical power outlet, 400 V AC
- **EPTC270**
- **HPM-F101** Hydraulic fixed displacement pump F1-101 for electric motor
- **HPM-F41** Hydraulic fixed displacement pump F1-41 for electric motor
- **HPM-F51** Hydraulic fixed displacement pump F1-51 for electric motor
- **HPM-F61** Hydraulic fixed displacement pump F1-61 for electric motor
- **HPM-F81** Hydraulic fixed displacement pump F1-81 for electric motor
- **HPM-T42** Hydraulic twin flow displacement pump F2-42/42 for electric motor
- **HPM-T53** Hydraulic twin flow displacement pump F2-53/53 for electric motor
- **HPM-T55** Hydraulic twin flow displacement pump F2-55/28 for electric motor
- **HPM-T70** Hydraulic twin flow displacement pump F2-70/35 for electric motor
- **HPM-V130** Hydraulic variable displacement pump VP1-130 for electric motor
- **HPM-V45** Hydraulic variable displacement pump VP1-45 for electric motor
- **HPM-V75** Hydraulic variable displacement pump VP1-75 for electric motor
- **HPM-V95** Hydraulic variable displacement pump VP1-95 for electric motor
- **PTR-D** Gearbox low-speed PTO, 1 rear connection DIN 5462/ISO 7653 for plug-in pump, 1000 Nm
- **PTR-DH** Gearbox high-speed PTO, 1 rear connection DIN 5462/ISO 7653 for plug-in pump, 600 Nm
- **PTR-DM** Gearbox medium-speed PTO, 1 rear connection DIN 5462/ISO 7653 for plug-in pump, 600 Nm
- **PTR-F** Gearbox low-speed PTO, 1 rear flange connection SAE 1410/ISO 7647 for propshaft, 1000 Nm
- **PTR-FH** Gearbox high-speed PTO, 1 rear flange connection SAE 1310/ISO 7647 for propshaft, 600 Nm
- **PTR-FL** Gearbox low-speed PTO, 1 rear flange connection SAE 1310/ISO 7647 for propshaft, 600 Nm
- **PTRD-D** Gearbox high-speed PTO, 1 rear + 1 front DIN 5462/ISO 7653 for plug-in pumps, 870 Nm
- **PTRD-D1** Gearbox high-speed PTO, 1 rear SAE 1410/ISO 7647, 1 front DIN5462/ISO7653, 870 Nm
- **PTRD-D2** Gearbox PTO, 2 rear hi/lo-speed SAE1310/1410/ISO7647, 1 front hi-speed DIN5462/ISO7653, 870/1000 Nm

- Standard Equipment
- Optional Equipment

For more detailed information about cab and powertrain equipment, please refer to separate specification sheets.

For all possible options and combinations of options please consult your Volvo sales contact who can create a specification to match your requirements using the Volvo Sales Support system (VSS).

The factory reserves the right to modify design and change equipment without previous notification. The specification can vary from country to country.

MODEL RANGE

FM 62 Rigid Tag Electric FM 62R TE

| | | | |
|---|--|---|--|
| <input type="checkbox"/> PTRD-F | Gearbox high-speed PTO, 1 rear flange connection SAE 1410/ISO 7647 for propshaft, 870 Nm | <input type="checkbox"/> DST-CF5 | Driver's seat Comfort, belt in seat, heated, adjustable lumbar&side support, extendable seat cushion |
| <input type="checkbox"/> HPG-F81 | Gearbox-mounted hydraulic pump F1-81, fixed displacement, single flow | <input type="checkbox"/> DST-CF6 | Driver's seat Comfort, belt in seat, heated, ventilated |
| Cab Interior, Driving | | <input type="checkbox"/> DST-LUX1 | Driver's seat Deluxe, belt in seat, heated, ventilated |
| <input checked="" type="checkbox"/> CRUIS-E | I-Cruise cruise control, I-Roll included | <input type="checkbox"/> PST-BAS1 | Passenger seat Basic, non-suspended |
| <input checked="" type="checkbox"/> DTRI-PER | Dashboard and door panels Peregrine (grey) and Raven (dark grey), steering wheel Raven | <input type="checkbox"/> PST-CF4 | Passenger seat Comfort, suspended, belt in seat |
| <input checked="" type="checkbox"/> STWPOS-L | Left-hand drive | <input type="checkbox"/> PST-CF5 | Passenger seat Comfort, suspended, belt in seat, electrically heated |
| <input type="checkbox"/> STWM-LE | Steering wheel material leather | <input checked="" type="checkbox"/> PST-STD2 | Passenger seat Regular, non-suspended |
| <input type="checkbox"/> STGW-AD2 | Manually adjustable steering wheel with neck tilt | <input type="checkbox"/> PST-STD4 | Passenger seat Regular, suspended |
| <input type="checkbox"/> STGW-ADJ | Manually adjustable steering wheel | <input type="checkbox"/> SBPRE-PS | Passenger seat belt pretensioner |
| <input checked="" type="checkbox"/> 1DAYB | One-day analogue tachograph, basic | <input type="checkbox"/> ARMRE-BB | Two armrests on both driver's and passenger seats |
| <input checked="" type="checkbox"/> 1DAYDIG4 | Gen 4, one-day digital tachograph, EC approved | <input type="checkbox"/> ARMRE-DB | Two armrests on driver's seat |
| <input type="checkbox"/> TAC-PK2 | Preparation kit for tachograph | <input type="checkbox"/> ARMRE-PB | Two armrests on passenger seat |
| <input type="checkbox"/> ARSL | Additional road speed limiter control (switch in dashboard) | <input type="checkbox"/> ARU-BAS | Vinyl armrest upholstery |
| <input checked="" type="checkbox"/> ESP-BAS1 | ESP for tractor combinations with ABS/EBS or rigid vehicles/combinations with std center of gravity | <input type="checkbox"/> ARU-LEA | Leather armrest upholstery |
| <input type="checkbox"/> ESPC-RO | Electronic stability program functionality control, switch - On/Reduced/Off | <input checked="" type="checkbox"/> FMAT-RUB | Black rubber floor mats |
| <input type="checkbox"/> HWSS-ACB | Adaptive cruise control with forward collision warning (stationary and moving objects) and emergency braking. Using both radar and camera to collect info. | <input type="checkbox"/> FMAT-TX2 | Two textile (dark grey on FH/FM/FMX, black on FH16) and two black rubber floor mats |
| <input checked="" type="checkbox"/> HWSS-FCB | Collision Warning with Emergency Brake (forward) | <input type="checkbox"/> LBK70 | Lower fixed bed 2000x700 mm, non-foldable, safety net included |
| <input checked="" type="checkbox"/> LSS-DW | Lane Keeping Support - lane departure warning | <input type="checkbox"/> MATL-FI | Mattress lower bed firm, pocket springs, recommended for body weight over 100 kg |
| <input type="checkbox"/> LSS-DW3 | Pilot Assist - active, continuous lane keeping | <input type="checkbox"/> MATL-SF | Mattress lower bed semi-firm, pocket springs, recommended for body weight up to 100 kg |
| <input type="checkbox"/> LCS2 | Side Collision Avoidance Support, passenger side collision warning (sound and visual information), passenger side | <input type="checkbox"/> OLMAT-BA | Overlay mattress, 28 mm thick black textile |
| <input checked="" type="checkbox"/> LCS4 | Side Collision Avoidance Support, side collision warning, both sides | <input type="checkbox"/> OLMAT-PR | Overlay mattress Premium, 35 mm thick black textile |
| <input checked="" type="checkbox"/> DAS-W | Driver Alert Support | <input type="checkbox"/> TBK60F | Fixed top bed 600x1900 mm, foldable up to 52° (depending on cab & upper storage), net included |
| <input type="checkbox"/> RSENS-W | Wipers rain sensor | <input type="checkbox"/> TBK70F | Fixed top bed 700x1900 mm, foldable up to 52° (depending on cab & upper storage), net included |
| <input checked="" type="checkbox"/> CU-ECC | Automatic climate control with sun sensor | <input type="checkbox"/> SLCP-BAS | Basic sleeper control panel (interior light, parking heater, roof hatch, door locks) |
| <input type="checkbox"/> CU-ECC2 | Automatic climate control with sun sensor, humidity sensor, air quality sensor and carbon filter | <input type="checkbox"/> ETSB-FRS | Storage at front of engine tunnel and immersed in RH side of tunnel |
| <input checked="" type="checkbox"/> IMMOBIL | Immobiliser | <input type="checkbox"/> ETSB-FS | Storage at back of engine tunnel, at back against rear cab wall and immersed in RH side of tunnel |
| <input type="checkbox"/> ALARM-E | Anti-theft alarm for cab, superstructure and trailer | <input type="checkbox"/> ETSB-S | Storage immersed in RH side of engine tunnel |
| <input type="checkbox"/> ISUNS-BS | Side interior roller blind on both sides, manually manoeuvred | <input type="checkbox"/> RUS-BAS | Storage in rear upper cab, 154 litres (300 mm high) |
| <input checked="" type="checkbox"/> ISUNS-DS | Side interior roller blind on driver's side, manually manoeuvred | <input type="checkbox"/> RUS-HIG | Storage in rear upper cab, 245 litres (440 mm high) |
| <input type="checkbox"/> ISUNF-RE | Interior roller blind, integrated in front shelf, electrically manoeuvred | <input type="checkbox"/> REF-ICPK | Preparation kit for refrigerator |
| <input checked="" type="checkbox"/> ISUNF-RM | Interior roller blind, integrated in front shelf, manually manoeuvred | <input type="checkbox"/> REFR-RUS | Refrigerator 28-litre, with dividers, on rear upper wall |
| <input type="checkbox"/> ADFS | Two extra DIN slots in front shelf, 165x40x180 mm (W x H x D) | <input type="checkbox"/> MICRO-PK | Preparation kit for microwave oven (electrical cables to front shelf) |
| <input checked="" type="checkbox"/> BUPALARM | Reversing warning | <input checked="" type="checkbox"/> BOTH-D | One bottle holder under dashboard centre section |
| <input checked="" type="checkbox"/> LOADIND | Load indicator, shown in instrument display and side display | <input type="checkbox"/> COFMA-PK | Preparation kit (24 V) for coffee maker |
| <input type="checkbox"/> REMC-MF | Wireless remote control, multi-functional | <input checked="" type="checkbox"/> INLI-BAS | Interior white light with smooth light transition at on/off, no dimming |
| <input checked="" type="checkbox"/> FIREXT3S | Fire extinguisher 3 kg, Swedish/English decal | <input type="checkbox"/> INLI-NL | Interior white and red (night) light with smooth light transition at on/off |
| <input type="checkbox"/> WARNVEST | Reflective vest, fulfils European standard EN 471 class 2 | <input type="checkbox"/> INLI-NLD | Interior white and red (night) light with smooth light transition at on/off and dimmer |
| <input checked="" type="checkbox"/> WARNTRI2 | Two warning triangles | <input type="checkbox"/> ARL-FLEX | Two (driver and passenger side) LED reading lamps with flexible arms, mounted on sidewalls |
| <input type="checkbox"/> AIDKIT | First aid kit containing sticking plaster, washing and drying pads, compresses, elastic bandages, respiratory mask, gloves and scissors. | <input checked="" type="checkbox"/> RH-EE | Roof skylight/emergency exit, tinted glass (not a hatch) |
| <input type="checkbox"/> WRITEPAD | Writing pad with paper clamp | <input type="checkbox"/> RH-ER | Roof hatch, electrically operated, steel, with emergency exit handle |
| Cab Interior, Living | | <input type="checkbox"/> RH-ETR | Roof hatch, electrically operated, tinted glass, rear opening 50 mm |
| <input checked="" type="checkbox"/> DST-CF4 | Driver's seat Comfort, belt in seat | <input type="checkbox"/> RH-MTR | Roof hatch, manually operated, tinted glass, rear opening 50 mm |
| <input checked="" type="checkbox"/> Standard Equipment | <input type="checkbox"/> Optional Equipment | <input checked="" type="checkbox"/> GLAS-TIN | Tinted windows |
| | | <input type="checkbox"/> AWIND-RF | Fixed window in back of cab (without curtains) |

For more detailed information about cab and powertrain equipment, please refer to separate specification sheets.

For all possible options and combinations of options please consult your Volvo sales contact who can create a specification to match your requirements using the Volvo Sales Support system (VSS).

The factory reserves the right to modify design and change equipment without previous notification. The specification can vary from country to country.

MODEL RANGE

FM 62 Rigid Tag Electric FM 62R TE

- SWIND-BS** Rear side window on both sides
 - SWIND-PS** Rear side window on passenger side
 - VANMIR** Vanity mirror in front shelf lid
 - AS-FUS** One extra shelf in each of the two front upper storage compartments
 - INFOT-PK** Preparation kit (bracket, security straps, and antenna cable) for mounting of TV above driver door
- Cab exterior**
- **EXTL-BA2** Exterior trim level basic 2
 - **BUMP-B** Plastic front bumper
 - BUMP-B2** Steel front bumper
 - **BUMP-SP** Front bumper spoiler
 - SIDEH-B** Guide rail on day cab, driver's side
 - SIDSTP-R** Side ladder and guide rail on day cab, driver's side
 - CTILTP-E** Electric cab tilt pump
 - **CTILTP-M** Manual cab tilt pump
 - FCABS-A** Air front cab suspension
 - **FCABS-M** Mechanical front cab suspension
 - RCABS-A** Air rear cab suspension
 - **RCABS-M** Mechanical rear cab suspension
 - MIRCFPCS** Rear-view and wide-angle mirrors (both sides), passenger corner camera (FM, FH)
 - MIRCFPCX** Rear-view and wide-angle mirrors (both sides), passenger corner camera (FMX)
 - MIRCMCP** Camera Monitor System and passenger corner camera
 - MIRCMS** Camera Monitor System
 - **MIRCOMF** Rear-view and wide-angle mirrors (both sides), kerb observation mirror
 - MIRCOMFX** Robust rear-view and wide-angle mirrors (both sides), kerb observation mirror
 - **AMIR-F20** Front close-view mirror above windscreen, passenger side (radius 200 mm)
 - AMIR-FCR** Front and corner close-view mirror, passenger side (radius 200 mm)
 - SUNV-H** Exterior front sun visor, transparent dark-grey
 - AD-ROOF** Roof air deflector
 - AD-SIDES** Cab side air deflectors, short
 - AD-CHASX** Chassis fairings, extended
 - ADCF-F** Aerodynamic flaps on chassis fairings
 - **HL-LED** LED headlamps
 - HL-LED3** LED headlamps with adaptive high beam
 - HLP-ST** Steel headlamp protectors (steel and plastic for FMX)
 - HLP-ST2** Steel and plastic headlamp protectors with steel grating for extra rough applications
 - **DRL-LED** Daytime running lamps (LED)
 - UDRL** Without daytime running lamps (LED)
 - DRIVL2** Extra main beam
 - **UDRIVL** Without extra main beam
 - **FOGL-WC** White front fog lamps
 - CL-STAT** Static cornering lights
 - ASL-RF2** Two LED spot lamps in sign box
 - IDLAMP-A** Three amber identification lamps on mid front roof
 - IDLAMP-W** Three white identification lamps on mid front roof
 - IDLMPSW** Switch in cab for identification lamps
 - BEACOA2F** Two amber LED beacons on cab front roof
 - BEACOA2R** Two amber LED beacons on cab rear roof
 - BEACON-P** Preparation kit for roof beacons
 - BEACONA4** Four amber LED beacons on roof - two on front, two on rear
 - CABPT-R1** One front cab roof pass-through on passenger side
 - **CABPT-R2** Two front cab roof pass-throughs, one on each side
 - SPOTP-F** Preparation kit for spot lamp in cab front, max 280 W
 - SPOTP-R** Preparation kit for spot lamp in cab roof, max 280 W
 - SPOTP-RF** Preparation kit for spot lamp in cab roof and front, max 280 W
 - ROS-IL2** Preparation kit for installation of roof sign illumination
 - CSGN-GTR** Globetrotter decal in the roof sign box
 - HORN-F1S** Single-tone Jericho horn behind grille, operated by steering wheel buttons
 - ANT-CBR** Preparation kit for communication/CB radio: roof-mounted single antenna and wiring
 - ACCBR-AP** Accessory brackets mounted on front roof, midroof and rear roof
 - ACCBR-F** Accessory bracket mounted on front roof
 - ACCBR-FM** Accessory brackets mounted on front roof and midroof
 - ACCBR-FR** Accessory brackets mounted on front and rear roof
 - ACCBR-M** Accessory bracket mounted on midroof
 - ACCBR-R** Accessory brackets mounted on mid-roof and rear roof
 - ACCBR-RM** Accessory bracket mounted on rear roof
 - REFS-CW** Reflecting white stripes mounted on cab side
 - REFS-TW** Reflecting white cab side stripes by-packed in cab
 - REFS-TY** Reflecting yellow cab side stripes by-packed in cab
- Superstructure preparations**
- SW745-EE** Swap body with front stop block for wheelbase 4600 mm, body lengths 7150/7450 mm, height 130 mm
 - SW745-FE** Swap body with front stop block for wheelbase 4800 mm, body lengths 7150/7450 mm, height 130 mm
 - SW745-GE** Swap body with front stop block for wheelbase 4600 mm, body lengths 7150/7450 mm, height 190 mm
 - SW745-HE** Swap body with front stop block for wheelbase 4800 mm, body lengths 7150/7450 mm, height 190 mm
 - SW782-ME** Swap body with front stop block for wheelbase 4900 mm, body lengths 7150/7450/7820 mm, height 130 mm
 - SW782-OE** Swap body with front stop block for wheelbase 4900 mm, body lengths 7150/7450/7820 mm, height 190 mm
 - CROSSRE** Cross reinforcement of frame for swap body
 - SRWL-PK** Preparation kit for LED reverse/work lamps at rear chassis, 3-pos switch (On/Off/Reverse auto On)
 - SWL-2FW** 2 white LED work lamps at front of chassis, and a 2-position switch (On/Off)
 - SWL-2RW** 2 white LED work lamps, rearward-facing on rear chassis (LH/RH side)
 - SWL-4W** 4 white LED work lamps on chassis (2 front, 2 rear) and a flexible switch (On/Off)
 - SWL-PK** Preparation kit for LED work lamps on chassis, with a 2-pos switch (On/Off)
 - WL-CHPK** Preparation kit for work lamp (switch with cable to frame, by gearbox)
 - WLC-H2A**
 - WLC-H2W** 2 white LED work lamps, high-mounted on back of cab (switch included)
 - WLC-PKCH** Preparation kit (cables and switch) for work lamp inside or outside superstructure
 - WLC-PKH** Preparation kit (cables and switch) for high-mounted work lamps on back of cab
 - WLC-PKL** Preparation kit (cables and switch) for low-mounted work lamps on back of cab
 - WLC-PKLH** Preparation kit (cables and switch) for low- and high-mounted work lamps on back of cab
 - ECBB-BAS** Body builder electrical centre, prepared for body builder module
 - **ECBB-HIG** Body builder electrical centre, body builder module with 14 high and 4 low digital outlets
 - BBCHAS1** One 7-pole bodywork connector on chassis
 - BBCHAS3** Three 7-pole bodywork connectors on chassis
 - BEPR-T2** Bodywork electrical and software preparation for tipper with remote control

■ Standard Equipment □ Optional Equipment

For more detailed information about cab and powertrain equipment, please refer to separate specification sheets.

For all possible options and combinations of options please consult your Volvo sales contact who can create a specification to match your requirements using the Volvo Sales Support system (VSS).

The factory reserves the right to modify design and change equipment without previous notification. The specification can vary from country to country.

MODEL RANGE

FM 62 Rigid Tag Electric FM 62R TE

- **EXSTER** Support for external steering control via body builder module
- **TD-LED** TD-LED detects trailers that have either bulb lights or LED lights. Continuous monitoring of the trailer connection status allows optimization of gear shifting and systems like Electronic Stability Program (ESP). Full diagnostics are available for bulb lights, while for LED lights the system cannot identify an "open circuit".
- **FBA-BTF** Front body attachment brackets, lower, for flexible body
- **FBA-BTSF** Front body attachment brackets, lower, for semi-flexible body
- **HBA-FSFB** Holes for body attachments, flexible/semi-flexible body
- **HBA-SB** Holes for body attachments, stiff body
- **RBA-T2** Rear body attachment brackets, lower
- **CRANEPK1** Frame-mounted crane interface plates, up to 10 tonne-metres
- **CRANEPK2** Frame-mounted crane interface plates, up to 20 tonne-metres
- **CRANEPK4** Frame-mounted crane interface plates, up to 40 tonne-metres
- **AUXL-SPK** Preparation kit (wiring and a switch in dashboard) for snow plough lamps
- **TAILPRE2** Tail lift preparation kit, wireless remote operation
- **TAILPREP** Tail lift preparation kit
- **AESW2** 2 bistable bodywork switches (marked AUX1/AUX2)
- **AESW2PK** 2 bistable bodywork switches (marked AUX1/AUX2) + prepared for 4 bistable switches (dummy switches)
- **AUXSW-4** Hardwiring for 4 extra switches (from body builder electrical centre to instrument panel)

Services

- **FMS-PK** Fleet management system gateway, preparation kit
- **DRUT1** My Truck service/app (remote vehicle status, alerts and control), 1-year prepaid subscription
- **DRUT2** My Truck service/app (remote vehicle status, alerts and control), 2-year prepaid subscription
- **DRUT3** My Truck service/app (remote vehicle status, alerts and control), 3-year prepaid subscription
- **DRUT4** My Truck service/app (remote vehicle status, alerts and control), 4-year prepaid subscription
- **DRUT5** My Truck service/app (remote vehicle status, alerts and control), 5-year prepaid subscription
- **TSRS2** Road sign recognition (not ISA compliant)