

# MODEL RANGE

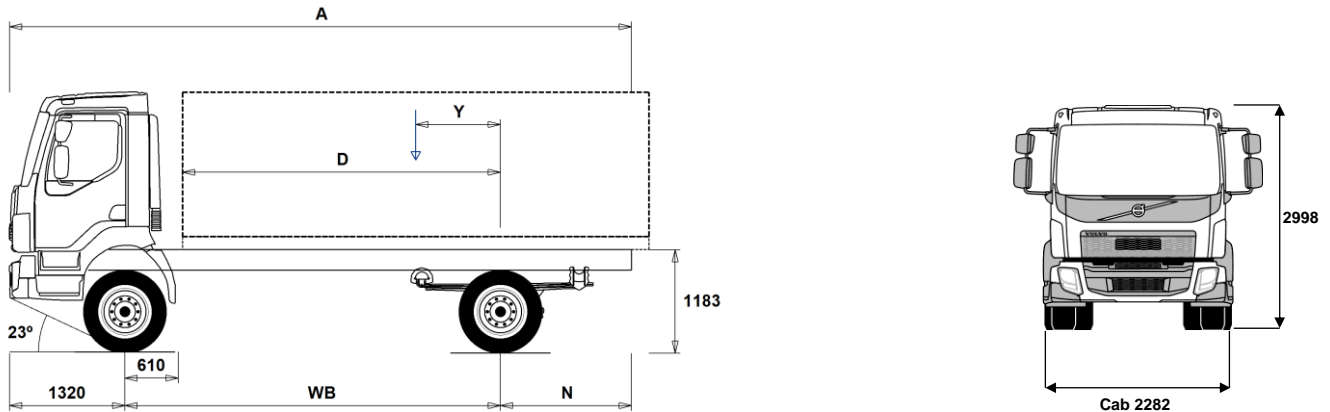

Volvo Trucks. Driving Progress

FL814 4x4 Rigid 14 tonne - Steel Suspension FL 44 R 814L



## Chassis Dimensions [mm]

WB Wheelbase	3350	3500	3800	4100
A Overall Chassis Length	6645	6975	7425	7955
D Center of rear axle to front of body	2690	2840	3140	3440
N Rear Overhang (Min.)	1515	1685	1885	2085
N Rear Overhang (Max.)	1975	2155	2305	2535
Y Center of Gravity for Payload (Min.)	459	483	524	568
Y Center of Gravity for Payload (Max.)	772	810	881	954

## Chassis Weights [kg]

Front Axle	3625	3620	3625	3625
Rear Axle	1815	1835	1860	1885
Kerb Weight	5440	5455	5485	5510
Payload (including body, driver, fuel, etc.)	8560	8545	8515	8490

## Turning Diameter [mm]

Turning Circle Diameter Kerb to Kerb	14200	14700	15800	16900
Turning Circle Diameter Wall to Wall	15200	15700	16800	17900

## Plated Weights [kg]

	Plated	Design
Gross Vehicle Weight	14000	14000
Gross Combination Weight	16500	16500
Front Axle	5600	5600
Rear Axle	9200	9200

## Important Notes

### Chassis Dimensions

Cab Height: +39 mm for CAB-CRW.  
 Front Axle to Back of Cab: +1230 mm for CAB-CRW, +237 mm for CAB-SSLP.  
 D-measure includes a front clearance of 50 mm and for rigid trucks also a subframe of 120 mm.  
 Height can vary  $\pm 20$  mm for leaf and  $\pm 10$  mm for air suspension.  
 All dimensions are for unladen chassis and any tag axles down.

Weight and dimensions are based upon the following tyres:  
 Front Axle Tyres: 275/70R22.5  
 Drive Axle Tyres: 275/70R22.5

Chassis weight includes oil, water, AdBlue, 0 litres fuel and without driver. Kerb weight can vary  $\pm 3\%$ .

Turning diameters are theoretically calculated.

Legal weights can differ from country to country.

For more detailed weight information, including optional equipment weights, ask your Volvo sales contact to enter your specification into the Volvo Weight Information system (WIS).

Do NOT use this drawing for bodybuilding. Refer to Volvo Bodybuilder Instructions and chassis assembly drawing FL44R814L.

# MODEL RANGE

FL814 4x4 Rigid 14 tonne - Steel Suspension FL 44 R 814L

## TRUCK USE

- **UNIFORM** Transport Adaption - Basic platform vehicle

## CORE COMPONENTS

- **RAD-L80** 80mm parabolic rear springs
- **CAB-CRW** Cab - Four-door - Six seater crewcab  
Designed and built to Swedish impact and ECE R29 regulations
- **CAB-DAY** Cab - Day - with steel safety cage design.  
Designed and built to Swedish impact and ECE R29 regulations
- **CAB-SSLP** Cab - Comfort with additional storage space or optional fold up bunk behind the driver - with steel safety cage design.  
Designed and built to Swedish impact and ECE R29 regulations.
- **EU6SCR** Emission level - Euro VI step D
- **D8K250** Engine - D8K250 six-cylinder 7.7 litre developing 250hp at 2100rpm.  
Peak torque 950Nm at 900-1700rpm.
- **D8K280** Engine - D8K280 six-cylinder 7.7 litre developing 280hp at 2100rpm.  
Peak torque 1050Nm at 950-1700rpm.
- **ZTO1006** Gearbox - Manual 6-speed overdrive
- **EBR-CEB** Engine Brake Type - Compression - producing 170kW at 2800rpm
- **EBR-EPG** Engine Brake Type - Exhaust - producing 120kW at 2800rpm

## Packages

- **DRIVEFL** Cab Package - Drive
- **VISIFL** Visibility Package -
- **AUDIODAB** Audio System - Digital DAB AM/FM Radio with Bluetooth - without CD player
- **AUDIOPD** Audio - Preparation for DAB radio including amplifier and aerial

## CHASSIS

- **FST-PAR3** Stiff parabolic front springs with shock absorbers and anti roll bar
- **FAL5.6** Front Axle Design Capacity - 5.6 tonne
- **RAL9.2** Rear Axle Design Capacity - 9.2 tonne
- **RSTAB1** Rear anti-roll bar - Normal stiffness
- **EBS-MED** Brake package - EBS medium including traction control & hill hold
- **RST-PAR3** Stiffer parabolic rear springs
- **FST8080** Chassis frame thickness - 8 mm web and flange
- **2BATT170** Battery Capacity - 2 x 170 Ah on the left-hand side
- **R130P** Right fuel tank - 130-litre plastic  
Min volume 130l  
Max volume 215l
- **UL-FUEL** Without left fuel tank
- **ADTP-R** Adblue tank position - Chassis mounted on the right-hand side
- **WHC-FIX1** Wheel chock - One fixed design
- **WHC-FIX2** Wheel chocks - Two fixed design
- **TOWMBRH** Tow member - High mounted in centre of frame - Check the GCW in the "Truck Use" section of this specification
- **C-RO40AG** Drawbar coupling - Rockinger 400 G145
- **TOWF-NO1** Front towing device - One pin in bumper
- **TOWF-NO2** Front towing device - Two pins in bumper
- **TOWR-ONE** Light trailer coupling - Pintle type hitch attached to rear cross member for an unbraked trailer
- **TREL15** Trailer electrical connection - Single 15 pin - ADR certified

- **TBC-EC** Trailer brakes with EC palm coupling connectors
- **RFEND-T** Rear mud wings - Temporary on drive axle for transport delivery only

## WHEELS & TYRES

- **RT-STEEL** Wheels - Steel rims
- **SPWT-F** Spare wheel & tyre - Spare with front tyre pattern
- **SWCP-T** Spare wheel supplied temporarily strapped to chassis
- **SWCP-TP** Spare wheel carrier transport mounted on frame (spare wheel carrier not included)
- **JACK-10T** 10 tonne bottle jack
- **GAUGE-TP** Tyre pressure gauge

## DRIVELINE EQUIPMENT

- **CS39A-O** Clutch - Single plate 395mm (16")
- **1COMP500** Air compressor - Single cylinder 360 cc - 500 litres per minute
- **2COM1080** Air compressor - Two-cylinder 1080 litres per minute
- **AIRIN-HI** Air intake - Mounted behind cab on the left-hand side
- **AIRIN-RL** Air intake - Chassis mounted behind cab on the left-hand side
- **ACL1ST** Air filter - Single element
- **ACL1ST-S** Air filter - two-stage element
- **24AL110B** Alternator capacity - 110 amp
- **CCV-C** Closed crankcase ventilation
- **CCV-OX** Open crankcase ventilation with oil separator and a maintenance free gas centrifuge
- **EST-AID** Engine starting aid -Preheating element in the air inlet manifold
- **PTER-100** Engine power-take-off - Rear-mounted with DIN100/ISO7646 flange
- **PTER-DIN** Engine power-take-off - Rear-mounted with DIN5462 (female) splined shaft for a close-coupled pump
- **PTER1400** Engine power-take-off - Rear-mounted with SAE 1410 flange
- **PTR-FH5** Rear PTO Gearbox S88 flange DIN connection
- **PTR-PH4** Rear PTO Gearbox S88 pump DIN connection
- **PTR-PK** Electrical and solenoid prep kit for gearbox PTO
- **PTR-ZF4** Rear PTO Gearbox 320Nm flange connection
- **PTR-ZF6** Rear PTO Gearbox 320Nm flange connection
- **ETC** Electronic throttle control - dash mounted switch for PTO speed control

## CAB INTERIOR

- **STWPOS-L** Steering wheel position - LEFT-HAND DRIVE
- **STWPOS-R** Steering wheel position - RIGHT-HAND DRIVE

## CAB EXTERIOR

- **SUNV-B** Exterior sun visor - Smoked grey
- **SUNV-PK** Exterior sun visor preparation kit only
- **BEACON-P** Roof beacons - wiring preparation only
- **BEACONA2** Two amber beacons directly mounted to cab roof

## SUPERSTRUCTURE PREPARATIONS

- **FBA-BTF** Lower front body attachments - For torsionally flexible - platform body
- **FBA-BTSF** Lower front body attachments - For torsionally semi-flexible body - box or curtainsider
- **RBA-T2** Rear body attachments - Divided
- **TAILPREP** Taillift preparation kit - cab switch and warning in driver display

## DELIVERY SERVICES

- **TGW-4G** Telematics gateway - GSM/GPRS/4G modem, WLAN
- **WVTA** EC Whole Vehicle Type Approved

- Standard Equipment
- Optional Equipment

For more detailed information about cab and powertrain equipment, please refer to separate specification sheets.

For all possible options and combinations of options please consult your Volvo sales contact who can create a specification to match your requirements using the Volvo Sales Support system (VSS).

The factory reserves the right to modify design and change equipment without previous notification. The specification can vary from country to country.

# MODEL RANGE

FL814 4x4 Rigid 14 tonne - Steel Suspension FL 44 R 814L

---

**VOLVO**

Volvo Truck Corporation  
volvotrucks.com