

MODEL RANGE

FL 42 R 8l Gvw16 Road Sweeper Leaf FL 42 RS816L

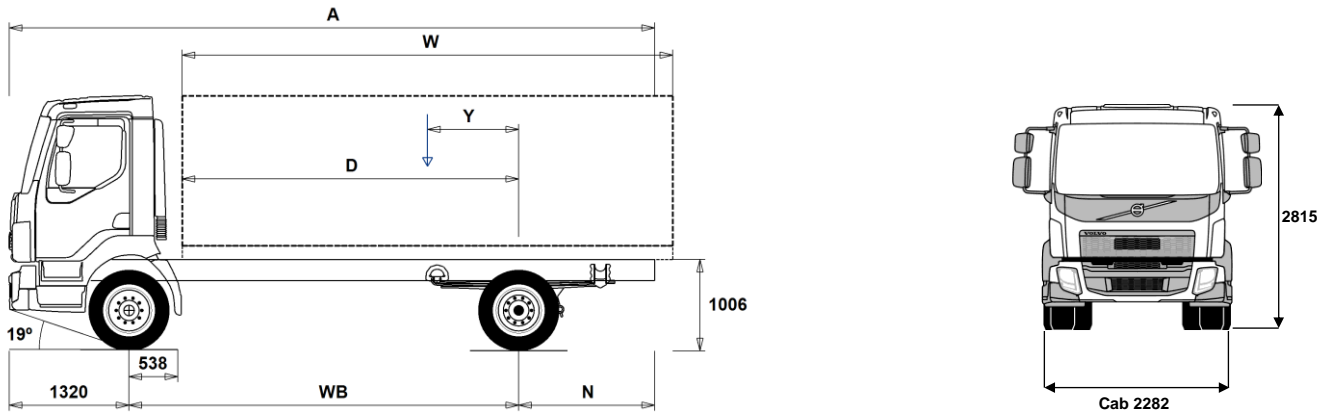

Chassis Dimensions [mm]

WB Wheelbase	3350	3600
A Overall Chassis Length	5700	5950
D Center of rear axle to front of body	2762	3012
N Rear Overhang	1030	1030
Y Center of Gravity for Payload (Min.)	490	525
Y Center of Gravity for Payload (Max.)	699	750
W Body Length (Min.)	4126	4524
W Body Length (Max.)	4544	4974

Chassis Weights [kg]

Front Axle	3455	3465
Rear Axle	1305	1320
Kerb Weight	4760	4785
Payload (including body, driver, fuel, etc.)	11240	11215

Turning Diameter [mm]

Turning Circle Diameter Kerb to Kerb	11900	12700
Turning Circle Diameter Wall to Wall	13200	14000

Plated Weights [kg]

Gross Vehicle Weight	16000
Gross Combination Weight	16500
Front Axle	5800
Rear Axle	10900

Design

Gross Vehicle Weight	16000
Gross Combination Weight	16500
Front Axle	5800
Rear Axle	10900

Important Notes

Chassis Dimensions

D-measure includes a front clearance of 50 mm and for rigid trucks also a subframe of 120 mm.

Height can vary ± 20 mm for leaf and ± 10 mm for air suspension. All dimensions are for unladen chassis and any tag axles down.

Weight and dimensions are based upon the following tyres:

Front Axle Tyres:	285/70R19.5
Drive Axle Tyres:	285/70R19.5

Chassis weight includes oil, water, AdBlue, 0 litres fuel and without driver. Kerb weight can vary ± 3%.

Turning diameters are theoretically calculated.

Legal weights can differ from country to country.

For more detailed weight information, including optional equipment weights, ask your Volvo sales contact to enter your specification into the Volvo Weight Information system (WIS).

Do NOT use this drawing for bodybuilding. Refer to Volvo Bodybuilder Instructions and chassis assembly drawing FL42RS816L.

MODEL RANGE

FL 42 R 8l Gvw16 Road Sweeper Leaf FL 42 RS816L

Core components

- **CHH-MED** Chassis height medium - approx. 900 mm above ground level
- **RAD-L80** Rear leaf suspension, 1 axle - 1 driven (80 mm wide leafs)
- **CAB-DAY** Day cab
- **EU6SCR** Euro 6 emission level with Selective Catalytic Reduction (SCR), particle filter and Exhaust Gas Recirculation (EGR)
- **D8K250** Six cylinder diesel engine, 7.7 litre Euro 6 SCR + EGR (Diesel Particulate Filter), 250 hp, 950 Nm
- **ZTO1006** Overdrive 6 speed manual ZF gearbox, 1050 Nm
- **EBR-CEB** Engine compression and exhaust brake
- **EBR-EPG** Engine brake with Exhaust pressure governor, EPG
- **RSS1125A** Rear single reduction solo axle - axle load 11 tonnes, GCW 25 tonnes

Packages

- **DRIVEFL** Driver convenience package FL
- **VISIFL** Visibility package FL - Optimizing the drivers field of vision around the cab
- **AUDIODAB** Audio System DAB
- **AUDIOPD** Audio Preparation DAB kit, incl. DAB-amplifier

Chassis

- **FST-PAR** Front parabolic leaf suspension (normal stiffness)
- **FAL5.8** Front axle load 5.8 tonnes
- **RAL10.9** Rear axle load 10.9 tonnes
- **RSTAB1** Rear stabilizer with normal stiffness
- **EBS-MED** EBS (Electronic Brake System) medium package
- **EBS-STD** EBS (Electronic Brake System) standard package
- **RST-PAR4** Short four leaf parabolic rear suspension with normal stiffness
- **FST7070** Frame section thickness - web 7.0 mm / flange 7.0 mm
- **2BATT170** Batteries 2x170 Ah
- **UR-FUEL** Without right diesel tank
- **UL-FUEL** Without left diesel tank
- **ADTP-R** AdBlue tank on right hand side
- **WHC-FIX1** One fixed wheel chock
- **TOWF-NO1** One front towing device
- **TOWF-NO2** Two front towing devices
- **RUP-FIX2** Fixed rear underrun protection, EC approved
- **RFEND-T** Transport mounted one-piece rear fenders
- **2024GSR** General safety regulations 2024

Rims and tyres

- **RT-AL** Brushed aluminium rims with std holes (long stud fixing) on all axles
- **RT-ALDP** Dura-Bright polished aluminium rims with std holes (long stud fixing) on all axles
- **RT-STEEL** Steel rims on all axles
- **SPWT-F** Spare wheel with tyre equal to front wheel
- **SWCP-T** Spare wheel transport mounted on top of frame
- **SWCP-TP** Spare wheel carrier transport mounted with the spare wheel on top of the frame rails
- **JACK-8T** Jack, 8 tonnes
- **GAUGE-TP** Tyre pressure gauge

Powertrain equipment

- **CS39A-O** Single plate clutch, plate diameter 395 mm
- **1COMP500** Single cylinder air compressor 360 cc / 500 l/min

■ Standard Equipment □ Optional Equipment

For more detailed information about cab and powertrain equipment, please refer to separate specification sheets.

For all possible options and combinations of options please consult your Volvo sales contact who can create a specification to match your requirements using the Volvo Sales Support system (VSS).

The factory reserves the right to modify design and change equipment without previous notification. The specification can vary from country to country.

- **2COM1080** Dual cylinder air compressor 720 cc / 1080 l/min
- **ACL1ST** Air cleaner with one filter element
- **24AL110B** Alternator 110 Ampere
- **CCV-C** Closed crankcase ventilation
- **CCV-OX** Open crankcase ventilation with oil separator and a maintenance free gas centrifuge
- **PTER-100** Rear engine mounted clutch independent power-take-off with flange connection (DIN 100 / ISO 7646)
- **PTER-DIN** Rear engine mounted clutch independent PTO with splined shaft groove (female) for a close coupled pump (DIN 5462 / ISO 7653)
- **PTER1400** Rear engine mounted clutch independent power-take-off with flange connection (SAE 1410 / ISO 7647)
- **PTR-FH1** Rear gearbox mounted Hydrocar S81 PTO with flange connection (DIN 90 / ISO 7646) for propeller shaft (800 Nm)
- **PTR-FH2** Rear gearbox mounted Hydrocar S84 PTO with flange connection (DIN 90 / ISO 7646) for propeller shaft (430 Nm)
- **PTR-FH5** Rear gearbox mounted Hydrocar S88 PTO with flange connection (DIN 90 / ISO 7646) for propeller shaft (450 Nm)
- **PTR-PH1** Rear gearbox mounted Hydrocar S81 PTO with connection (DIN 5462 / ISO 7653) for pump (800 Nm)
- **PTR-PH2** Rear gearbox mounted Hydrocar S84 PTO with connection (DIN 5462 / ISO 7653) for pump (430 Nm)
- **PTR-PH4** Rear gearbox mounted Hydrocar S88 PTO with connection (DIN 5462 / ISO 7653) for pump (450 Nm)
- **PTR-ZF2** Rear gearbox mounted ZF PTO with flange connection (DIN 100 / ISO 7646) for prop shaft (410 Nm)
- **PTR-ZF3** Rear gearbox mounted ZF PTO with connection (DIN 5462 / ISO 7653) for pump (410 Nm)
- **PTR-ZF4** Rear gearbox mounted ZF PTO with flange connection (DIN 100 / ISO 7646) for prop shaft (320 Nm)
- **PTR-ZF5** Rear gearbox mounted ZF PTO with connection (DIN 5462 / ISO 7653) for pump (320 Nm)
- **PTR-ZF6** Rear gearbox mounted ZF PTO with flange connection (DIN 100 / ISO 7646) for prop shaft (270 Nm)
- **ETC** Electronic throttle control - dash mounted switch for PTO speed control

Cab interior

- **TAS-DIG4** Gen 4 one day digital tachograph, EC approved (GNSS & DSRC, EU 2020/1054)

Cab exterior

- **SUNV-B** Exterior transparent dark grey front sun visor
- **SUNV-PK** Exterior front sun visor installation preparation kit (fasteners)
- **BEACON-P** Prepared for roof beacons
- **BEACONA2** 2 amber beacon, roof mounted warning lamps

Superstructure preparations

- **FBA-BTSF** Front body attachments for semi-flexible body

Services

- **TGW-4G** Telematics gateway with 4G modem
- **WVTA** Whole Vehicle Type Approved

MODEL RANGE

FL 42 R 8l Gvw16 Road Sweeper Leaf FL 42 RS816L

Volvo Trucks. Driving Progress