

# MODEL RANGE

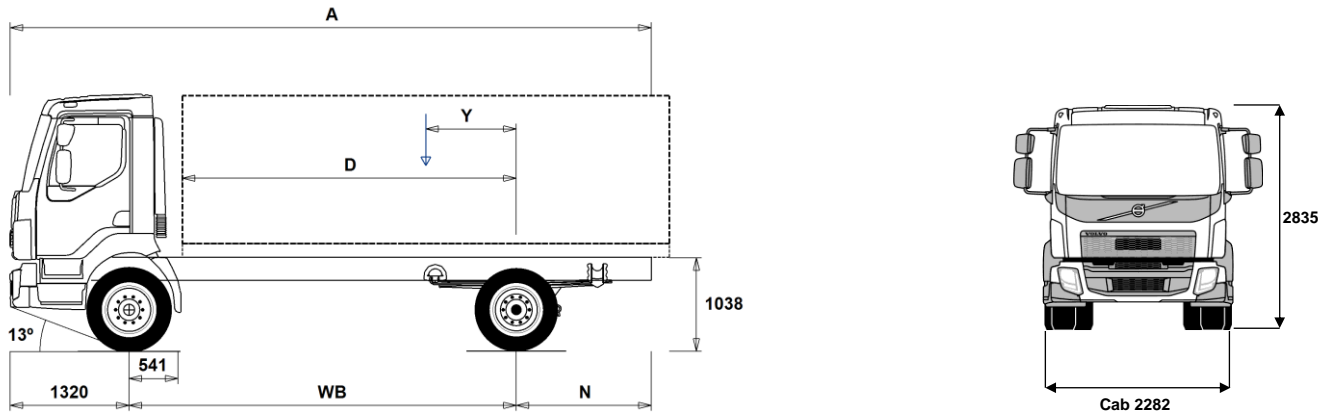

Volvo Trucks. Driving Progress

FL818 4x2 Rigid 18 tonne - Steel Suspension FL 42 R 818L



## Chassis Dimensions [mm]

WB Wheelbase	3500	3800	4100	4400	4700	5000	5300	5600	5900	6200	6500	6800
A Overall Chassis Length	6975	7425	7955	8425	8915	9435	9915	10425	10835	11430	11730	12030
D Center of rear axle to front of body	2909	3209	3509	3809	4109	4409	4709	5009	5309	5609	5909	6209
N Rear Overhang (Min.)	1515	1615	1515	1615	1615	1615	1615	1615	1615	1615	1615	1615
N Rear Overhang (Max.)	2155	2305	2535	2705	2895	3115	3295	3505	3615	3910	3910	3910
Y Center of Gravity for Payload (Min.)	844	917	990	1063	1137	1210	1283	1357	1427	1503	1571	1640
Y Center of Gravity for Payload (Max.)	1006	1093	1181	1268	1356	1444	1531	1620	1705	1796	1878	1962

## Chassis Weights [kg]

Front Axle	3370	3375	3380	3385	3390	3390	3405	3405	3415	3415	3435	3445
Rear Axle	1650	1670	1700	1720	1745	1770	1800	1820	1840	1865	1880	1885
Kerb Weight	5020	5045	5080	5105	5135	5160	5205	5225	5255	5280	5315	5330
Payload (including body, driver, fuel, etc.)	12980	12955	12920	12895	12865	12840	12795	12775	12745	12720	12685	12670

## Turning Diameter [mm]

Turning Circle Diameter Kerb to Kerb	13100	14000	14900	15900	16800	17800	18700	19700	20600	21500	22500	23400
Turning Circle Diameter Wall to Wall	14200	15100	16100	17000	18000	18900	19900	20800	21700	22700	23600	24600

## Plated Weights [kg]

	Plated	Design
Gross Vehicle Weight	18000	18000
Gross Combination Weight	24000	24000
Front Axle	7100	7100
Rear Axle	11500	11500

## Important Notes

### Chassis Dimensions

Front Axle to Back of Cab: +291 mm for CAB-SSLP.  
 D-measure includes a front clearance of 50 mm and for rigid trucks also a subframe of 120 mm.  
 Height can vary  $\pm 20$  mm for leaf and  $\pm 10$  mm for air suspension.  
 All dimensions are for unladen chassis and any tag axles down.

Weight and dimensions are based upon the following tyres:

Front Axle Tyres: 315/60R22.5  
 Drive Axle Tyres: 295/60R22.5

Chassis weight includes oil, water, AdBlue, 0 litres fuel and without driver. Kerb weight can vary  $\pm 3\%$ .

Turning diameters are theoretically calculated.

Legal weights can differ from country to country.

For more detailed weight information, including optional equipment weights, ask your Volvo sales contact to enter your specification into the Volvo Weight Information system (WIS).

Do NOT use this drawing for bodybuilding. Refer to Volvo Bodybuilder Instructions and chassis assembly drawing FL42R818L.

# MODEL RANGE

FL818 4x2 Rigid 18 tonne - Steel Suspension FL 42 R 818L

## CORE COMPONENTS

- **RAD-L80** 80mm parabolic rear springs
- **CAB-DAY** Cab - Day - with steel safety cage design. Designed and built to Swedish impact and ECE R29 regulations
- **CAB-SSLP** Cab - Comfort with additional storage space or optional fold up bunk behind the driver - with steel safety cage design. Designed and built to Swedish impact and ECE R29 regulations.
- **EU6SCR** Emission level - Euro VI step D
- **D8K250** Engine - D8K250 six-cylinder 7.7 litre developing 250hp at 2100rpm. Peak torque 950Nm at 900-1700rpm.
- **D8K280** Engine - D8K280 six-cylinder 7.7 litre developing 280hp at 2100rpm. Peak torque 1050Nm at 950-1700rpm.
- **AL306** Gearbox - Allison AL306 6-speed automatic gearbox. If a PTO is required it must be specified from the factory
- **ATO1056** Gearbox - Automated 6-speed I-sync overdrive
- **ZTO1006** Gearbox - Manual 6-speed overdrive
- **EBR-CEB** Engine Brake Type - Compression - producing 170kW at 2800rpm
- **EBR-EPG** Engine Brake Type - Exhaust - producing 120kW at 2800rpm
- **RSS1132A** Drive Axle - RS1132A single reduction with differential lock - design GCW 32tonne

## Packages

- **DRIVEFL** Cab Package - Drive
- **VISIFL** Visibility Package -
- **AIRFLOW** Airflow Package -
- **AUDIODAB** Audio System - Digital DAB AM/FM Radio with Bluetooth - without CD player
- **AUDIOPD** Audio - Preparation for DAB radio including amplifier and aerial

## CHASSIS

- **FST-PAR** Front suspension type - Parabolic front springs with shock absorbers and anti-roll bar
- **RSTAB1** Rear anti-roll bar - Normal stiffness
- **EBS-MED** Brake package - EBS medium including traction control & hill hold
- **EBS-STD** Brake package - EBS standard package without traction control
- **RST-PAR1** Rear suspension type - Parabolic springs
- **RST-PAR3** Stiffer parabolic rear springs
- **FST7070** Chassis frame thickness - 7 mm web and flange
- **FST8080** Chassis frame thickness - 8 mm web and flange
- **2BATT170** Battery Capacity - 2 x 170 Ah on the left-hand side
- **ADR2** ADR Adaptation - For transportation of dangerous goods on the road - Note does NOT include safe loading pass package if required this is quoted separately
- **R215P** Right fuel tank - 215-litre plastic  
Min volume 80l  
Max volume 430l
- **UL-FUEL** Without left fuel tank  
Min volume 160l  
Max volume 210l
- **ADTP-L** Adblue tank position - Chassis mounted on the left-hand side
- **ADTP-R** Adblue tank position - Chassis mounted on the right-hand side
- **WHC-FIX1** Wheel chock - One fixed design
- **WHC-FIX2** Wheel chocks - Two fixed design
- **TOWMBRH** Tow member - High mounted in centre of frame - Check the GCW in the "Truck Use" section of this specification

- **C-RO40AG** Drawbar coupling - Rockinger 400 G145
- **TOWF-NO1** Front towing device - One pin in bumper
- **TOWF-NO2** Front towing device - Two pins in bumper
- **TOWR-ONE** Light trailer coupling - Pintle type hitch attached to rear cross member for an unbraked trailer
- **TREL15** Trailer electrical connection - Single 15 pin - ADR certified
- **TBC-EC** Trailer brakes with EC palm coupling connectors
- **RUP-FIX2** Rear underrun protection - Fixed EC approved
- **RFEND-T** Rear mud wings - Temporary on drive axle for transport delivery only

## WHEELS & TYRES

- **RT-ALDP** Wheels - Alcoa Dura-Bright aluminium rims - standard holes for long stud fixing
- **RT-STEEL** Wheels - Steel rims
- **SPWT-F** Spare wheel & tyre - Spare with front tyre pattern
- **SWCP-LF** Spare wheel carrier on left side of chassis ahead of rear axle
- **SWCP-R** Spare wheel carrier rear mounted below frame.
- **SWCP-T** Spare wheel supplied temporarily strapped to chassis
- **SWCP-TP** Spare wheel carrier transport mounted on frame (spare wheel carrier not included)
- **JACK-10T** 10 tonne bottle jack
- **GAUGE-TP** Tyre pressure gauge

## DRIVELINE EQUIPMENT

- **CS39A-O** Clutch - Single plate 395mm (16")
- **RET-TPT** Retarder for automatic gearbox
- **TC-HWO** Transmission oil cooler - water to oil
- **1COMP500** Air compressor - Single cylinder 360 cc - 500 litres per minute
- **2COM1080** Air compressor - Two-cylinder 1080 litres per minute
- **AIRIN-HI** Air intake - Mounted behind cab on the left-hand side
- **AIRIN-RL** Air intake - Chassis mounted behind cab on the left-hand side
- **ACL1ST** Air filter - Single element
- **ACL1ST-S** Air filter - two-stage element
- **24AL110B** Alternator capacity - 110 amp
- **24AL130B** Alternator capacity - 130 amp
- **CCV-C** Closed crankcase ventilation
- **CCV-OX** Open crankcase ventilation with oil separator and a maintenance free gas centrifuge
- **EST-AID** Engine starting aid -Preheating element in the air inlet manifold
- **PTER-100** Engine power-take-off - Rear-mounted with DIN100/ISO7646 flange
- **PTER-DIN** Engine power-take-off - Rear-mounted with DIN5462 (female) splined shaft for a close-coupled pump
- **PTER1400** Engine power-take-off - Rear-mounted with SAE 1410 flange
- **PR-HF4S** Live-drive PTO for Allison gearbox output 400Nm for flange connection  
mounted on the side of the torque convertor
- **PR-HF4SH** Live-drive high speed PTO for Allison gearbox output 400Nm for hydraulic pump connection  
mounted on the side of the torque convertor
- **PR-HF6S** Live-drive PTO for Allison gearbox output 600Nm for flange connection  
mounted on the side of the torque convertor
- **PR-HP4S** Live-drive PTO for Allison gearbox output 400Nm for hydraulic pump connection  
mounted on the side of the torque convertor
- **PR-HP4SH** Live-drive high speed PTO for Allison gearbox output 400Nm for hydraulic pump connection  
mounted on the side of the torque convertor
- **PR-HP6S** Live-drive PTO for Allison gearbox output 600Nm for hydraulic pump connection  
mounted on the side of the torque convertor
- **PTR-FH1** Rear PTO Gearbox S81 flange DIN connection

■ Standard Equipment      □ Optional Equipment

For more detailed information about cab and powertrain equipment, please refer to separate specification sheets.

For all possible options and combinations of options please consult your Volvo sales contact who can create a specification to match your requirements using the Volvo Sales Support system (VSS).

The factory reserves the right to modify design and change equipment without previous notification. The specification can vary from country to country.

# MODEL RANGE

FL818 4x2 Rigid 18 tonne - Steel Suspension FL 42 R 818L

---

- PTR-FH2** Rear PTO Gearbox S84 flange DIN connection
- PTR-FH5** Rear PTO Gearbox S88 flange DIN connection
- PTR-PH1** Rear PTO Gearbox S81 pump DIN connection
- PTR-PH2** Rear PTO Gearbox S84 pump DIN connection
- PTR-PH4** Rear PTO Gearbox S88 pump DIN connection
- PTR-PK** Electrical and solenoid prep kit for gearbox PTO
- PTR-ZF2** Rear Power Take Off flange DIN connection
- PTR-ZF3** Rear Power Take Off Gearbox pump DIN connection
- PTR-ZF4** Rear PTO Gearbox 320Nm flange connection
- PTR-ZF5** Rear PTO Gearbox 320Nm pump connection
- PTR-ZF6** Rear PTO Gearbox 320Nm flange connection
  
- HPG-F101** Gearbox mounted hydraulic pump F1-101, fixed displacement, single flow.
- HPG-F41** Gearbox mounted hydraulic pump F1-41, fixed displacement, single flow.
- HPG-F51** Gearbox mounted hydraulic pump F1-51, fixed displacement, single flow.
- HPG-F61** Gearbox mounted hydraulic pump F1-61, fixed displacement, single flow.
- HPG-F81** Gearbox mounted hydraulic pump F1-81, fixed displacement, single flow.
  
- ETC** Electronic throttle control - dash mounted switch for PTO speed control

## CAB INTERIOR

- STWPOS-L** Steering wheel position - LEFT-HAND DRIVE
- STWPOS-R** Steering wheel position - RIGHT-HAND DRIVE

## CAB EXTERIOR

- SUNV-B** Exterior sun visor - Smoked grey
- SUNV-PK** Exterior sun visor preparation kit only
  
- AD-SIDES** Cab side air deflector, short extension panels.
  
- BEACON-P** Roof beacons - wiring preparation only
- BEACONA2** Two amber beacons directly mounted to cab roof

## SUPERSTRUCTURE PREPARATIONS

- FBA-BTF** Lower front body attachments - For torsionally flexible - platform body
- FBA-BTSF** Lower front body attachments - For torsionally semi-flexible body - box or curtainsider
  
- RBA-T2** Rear body attachments - Divided
  
- TAILPREP** Taillift preparation kit - cab switch and warning in driver display

## DELIVERY SERVICES

- TGW-4G** Telematics gateway - GSM/GPRS/4G modem, WLAN
- WVTA** EC Whole Vehicle Type Approved

**VOLVO**

Volvo Truck Corporation  
volvotrucks.com