

MODEL RANGE

FL 42R GVW18 8L leaf FL 42 R 818L

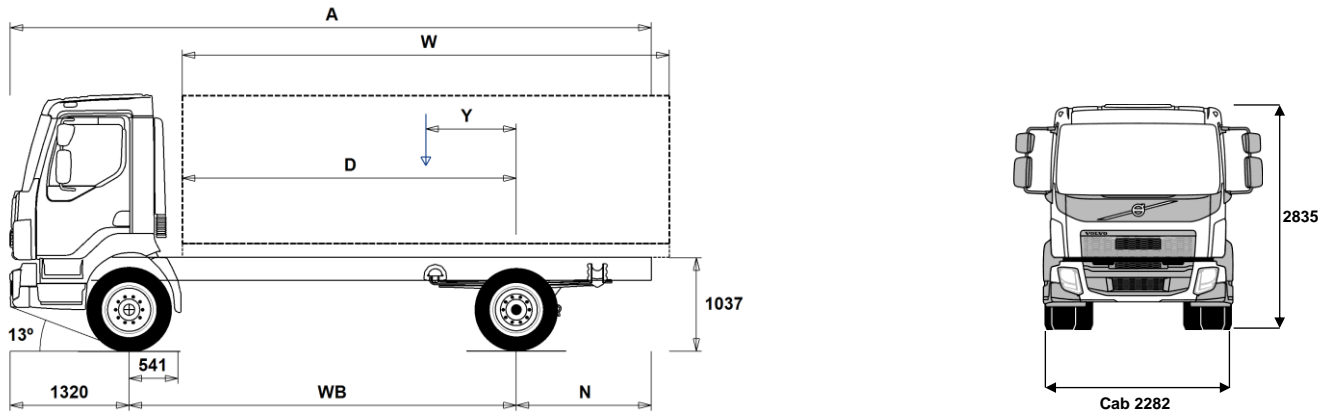

Chassis Dimensions [mm]

WB Wheelbase	3500	3800	4100	4400	4700	5000	5300	5600	5900	6200	6500	6800
A Overall Chassis Length	6975	7425	7955	8425	8915	9435	9915	10425	10835	11430	11730	12030
D Center of rear axle to front of body	2909	3209	3509	3809	4109	4409	4709	5009	5309	5609	5909	6209
N Rear Overhang (Min.)	1515	1615	1515	1615	1615	1615	1615	1615	1615	1615	1615	1615
N Rear Overhang (Max.)	2155	2305	2535	2705	2895	3115	3295	3505	3615	3910	3910	3910
Y Center of Gravity for Payload (Min.)	847	920	994	1067	1140	1215	1287	1361	1432	1508	1576	1646
Y Center of Gravity for Payload (Max.)	1009	1096	1185	1272	1360	1449	1536	1625	1711	1802	1884	1969
W Body Length (Min.)	3801	4225	4649	5074	5498	5920	6346	6768	7197	7615	8050	8481
W Body Length (Max.)	4125	4578	5031	5484	5937	6389	6844	7295	7754	8201	8666	9126

Chassis Weights [kg]

Front Axle	3370	3370	3375	3380	3385	3390	3400	3400	3415	3415	3430	3440
Rear Axle	1685	1705	1735	1755	1780	1805	1835	1855	1875	1900	1915	1920
Kerb Weight	5055	5075	5110	5135	5165	5195	5235	5255	5290	5315	5345	5360
Payload (including body, driver, fuel, etc.)	12945	12925	12890	12865	12835	12805	12765	12745	12710	12685	12655	12640

Turning Diameter [mm]

Turning Circle Diameter Kerb to Kerb	13100	14000	14900	15900	16800	17800	18700	19700	20600	21500	22500	23400
Turning Circle Diameter Wall to Wall	14200	15100	16100	17000	18000	18900	19900	20800	21700	22700	23600	24600

Plated Weights [kg]

	Design
Gross Vehicle Weight	18000
Gross Combination Weight	21000
Front Axle	7100
Rear Axle	11500

Important Notes

Chassis Dimensions

Front Axle to Back of Cab: +277 mm for CAB-SSLP.
 D-measure includes a front clearance of 50 mm and for rigid trucks also a subframe of 120 mm.
 Height can vary ± 20 mm for leaf and ± 10 mm for air suspension.
 All dimensions are for unladen chassis and any tag axles down.

Weight and dimensions are based upon the following tyres:
 Front Axle Tyres: 315/60R22.5
 Drive Axle Tyres: 295/60R22.5

Chassis weight includes oil, water, AdBlue, 0 litres fuel and without driver. Kerb weight can vary ± 3%.

Turning diameters are theoretically calculated.

Legal weights can differ from country to country.

For more detailed weight information, including optional equipment weights, ask your Volvo sales contact to enter your specification into the Volvo Weight Information system (WIS).

Do NOT use this drawing for bodybuilding. Refer to Volvo Bodybuilder Instructions and chassis assembly drawing FL42R818L.

MODEL RANGE

FL 42R GVW18 8L leaf FL 42 R 818L

Core components

- **RAD-L80** Rear leaf suspension, 1 axle - 1 driven (80 mm wide leafs)
- **CAB-DAY** Day cab
- **CAB-SSLP** Comfort cab
- **EU6SCR** Euro 6 emission level with Selective Catalytic Reduction (SCR), particle filter and Exhaust Gas Recirculation (EGR)
- **D8K250** Six cylinder diesel engine, 7.7 litre Euro 6 SCR + EGR (Diesel Particulate Filter), 250 hp, 950 Nm
- **D8K280** Six cylinder diesel engine, 7.7 litre Euro 6 SCR + EGR (Diesel Particulate Filter), 280 hp, 1050 Nm
- **AL306** Automatic 6-speed Allison gearbox, max input torque 1695 Nm
- **ATO1056** I-Sync, Automated manual 6 speed gearbox, 1070 Nm
- **ZTO1006** Overdrive 6 speed manual ZF gearbox, 1050 Nm
- **EBR-CEB** Engine compression and exhaust brake
- **EBR-EPG** Engine brake with Exhaust pressure governor, EPG
- **RSS1132A** Rear single reduction solo axle - axle load 11 tonnes, GCW 32.5 tonnes

Packages

- **DRIVEFL** Driver convenience package FL
- **VISIFL** Visibility package FL - Optimizing the drivers field of vision around the cab
- **AIRFLOW** Airflow package FL - Includes adjustable roof spoiler, side deflector and sun visor
- **AUDIODAB** Audio System DAB
- **AUDIOPD** Audio Preparation DAB kit, incl. DAB-amplifier

Chassis

- **FST-PAR** Front parabolic leaf suspension (normal stiffness)
- **RSTAB1** Rear stabilizer with normal stiffness
- **EBS-MED** EBS (Electronic Brake System) medium package
- **EBS-STD** EBS (Electronic Brake System) standard package
- **RST-PAR1** Rear parabolic leaf suspension
- **RST-PAR3** Three leaf parabolic rear suspension, stiffer than normal
- **FST7070** Frame section thickness - web 7.0 mm / flange 7.0 mm
- **FST8080** Frame section thickness - web 8.0 mm / flange 8.0 mm
- **2BATT170** Batteries 2x170 Ah
- **ADR2** ADR adaptation, 1 switch in dashboard, 1 outside on back of cab
- **R80P** Right 80 litre plastic diesel tank
Min volume 80l
Max volume 430l
- **UL-FUEL** Without left diesel tank
Min volume 160l
Max volume 210l
- **ADTP-L** AdBlue tank on left hand side
- **ADTP-R** AdBlue tank on right hand side
- **WHC-FIX1** One fixed wheel chock
- **WHC-FIX2** Two fixed wheel chocks
- **TOWMBRH** High mounted towing member, in centre of frame
- **C-RO40AG** Towing coupling Rockinger 400 G-145
- **TOWF-NO1** One front towing device
- **TOWF-NO2** Two front towing devices
- **TOWR-ONE** One rear towing device in frame end cross member
- **TREL15** 15 pol electrical trailer connector (ADR certified)
- **TBC-EC** Trailer brake connection, European Community
- **RUP-FIX2** Fixed rear underrun protection, EC approved
- **RFEND-T** Transport mounted one-piece rear fenders

■ Standard Equipment

□ Optional Equipment

For more detailed information about cab and powertrain equipment, please refer to separate specification sheets.

For all possible options and combinations of options please consult your Volvo sales contact who can create a specification to match your requirements using the Volvo Sales Support system (VSS).

The factory reserves the right to modify design and change equipment without previous notification. The specification can vary from country to country.

- **2024GSR** General safety regulations 2024

Rims and tyres

- **RT-STEEL** Steel rims on all axles
- **SPWT-F** Spare wheel with tyre equal to front wheel
- **SWCP-LF** Spare wheel carrier on left side in front of rear axle
- **SWCP-R** Spare wheel carrier transport mounted behind rear axle, on right-hand side (FH, FM)/below frame (FL, FL)
- **SWCP-T** Spare wheel transport mounted on top of frame
- **SWCP-TP** Spare wheel carrier transport mounted with the spare wheel on top of the frame rails
- **JACK-10T** Jack, 10 tonnes
- **GAUGE-TP** Tyre pressure gauge

Powertrain equipment

- **CS39A-O** Single plate clutch, plate diameter 395 mm
- **RET-TPT** Retarder for hydraulic gearbox
- **TC-HWO** Oil cooler for hydraulic transmissions – water/oil
- **1COMP500** Single cylinder air compressor 360 cc / 500 l/min
- **2COM1080** Dual cylinder air compressor 720 cc / 1080 l/min
- **AIRIN-HI** High air intake
- **AIRIN-RL** Low air intake, chassis mounted behind cab on left hand side
- **ACL1ST** Air cleaner with one filter element
- **ACL1ST-S** Air cleaner with additional filter element
- **24AL110B** Alternator 110 Ampere
- **24AL130B** Alternator 130 Ampere
- **CCV-C** Closed crankcase ventilation
- **CCV-OX** Open crankcase ventilation with oil separator and a maintenance free gas centrifuge
- **EST-AID** Engine start pre-heating element
- **PTER-100** Rear engine mounted clutch independent power-take-off with flange connection (DIN 100 / ISO 7646)
- **PTER-DIN** Rear engine mounted clutch independent PTO with splined shaft groove (female) for a close coupled pump (DIN 5462 / ISO 7653)
- **PTER1400** Rear engine mounted clutch independent power-take-off with flange connection (SAE 1410 / ISO 7647)
- **PR-HF4S** PTO transmission, Hydrocar, flange connection, side mounted, high speed
- **PR-HF4SH** PTO transmission, Hydrocar, flange connection, side mounted, high speed
- **PR-HF6S** PTO transmission, Hydrocar, flange connection, side mounted
- **PR-HP4S** PTO transmission, Hydrocar, pump connection, side mounted
- **PR-HP4SH** PTO transmission, Hydrocar, pump connection, side mounted, high speed
- **PR-HP6S** PTO transmission, Hydrocar, pump connection, side mounted
- **PTR-FH1** Rear gearbox mounted Hydrocar S81 PTO with flange connection (DIN 90 / ISO 7646) for propeller shaft (800 Nm)
- **PTR-FH2** Rear gearbox mounted Hydrocar S84 PTO with flange connection (DIN 90 / ISO 7646) for propeller shaft (430 Nm)
- **PTR-FH5** Rear gearbox mounted Hydrocar S88 PTO with flange connection (DIN 90 / ISO 7646) for propeller shaft (450 Nm)
- **PTR-PH1** Rear gearbox mounted Hydrocar S81 PTO with connection (DIN 5462 / ISO 7653) for pump (800 Nm)
- **PTR-PH2** Rear gearbox mounted Hydrocar S84 PTO with connection (DIN 5462 / ISO 7653) for pump (430 Nm)
- **PTR-PH4** Rear gearbox mounted Hydrocar S88 PTO with connection (DIN 5462 / ISO 7653) for pump (450 Nm)
- **PTR-PK** Electrical and solenoid prep kit for gearbox PTO
- **PTR-ZF2** Rear gearbox mounted ZF PTO with flange connection (DIN 100 / ISO 7646) for prop shaft (410 Nm)
- **PTR-ZF3** Rear gearbox mounted ZF PTO with connection (DIN 5462 / ISO 7653) for pump (410 Nm)
- **PTR-ZF4** Rear gearbox mounted ZF PTO with flange connection (DIN 100 / ISO 7646) for prop shaft (320 Nm)
- **PTR-ZF5** Rear gearbox mounted ZF PTO with connection (DIN 5462 / ISO 7653) for pump (320 Nm)
- **PTR-ZF6** Rear gearbox mounted ZF PTO with flange connection (DIN 100 / ISO 7646) for prop shaft (270 Nm)

MODEL RANGE

FL 42R GVW18 8L leaf FL 42 R 818L

- **HPG-F101** Gearbox mounted hydraulic pump F1-101, fixed displacement, single flow
- **HPG-F41** Gearbox mounted hydraulic pump F1-41, fixed displacement, single flow
- **HPG-F51** Gearbox mounted hydraulic pump F1-51, fixed displacement, single flow
- **HPG-F61** Gearbox mounted hydraulic pump F1-61, fixed displacement, single flow
- **HPG-F81** Gearbox mounted hydraulic pump F1-81, fixed displacement, single flow
- **ETC** Electronic throttle control - dash mounted switch for PTO speed control

Cab interior

- **TAS-DIG4** Gen 4 one day digital tachograph, EC approved (GNSS & DSRC, EU 2020/1054)

Cab exterior

- **SUNV-B** Exterior transparent dark grey front sun visor
- **SUNV-PK** Exterior front sun visor installation preparation kit (fasteners)
- **AD-SIDES** Short cab side air deflectors
- **BEACON-P** Prepared for roof beacons
- **BEACONA2** 2 amber beacon, roof mounted warning lamps

Superstructure preparations

- **FBA-BTF** Front body attachments for flexible body
- **FBA-BTSF** Front body attachments for semi-flexible body
- **RBA-T2** Rear body attachments for helper frame
- **TAILPREP** Tail lift preparation kit

Services

- **TGW-4G** Telematics gateway with 4G modem
- **WVTA** Whole Vehicle Type Approved