

MODEL RANGE

FL 42R GVW16 8L leaf FL 42 R 816L

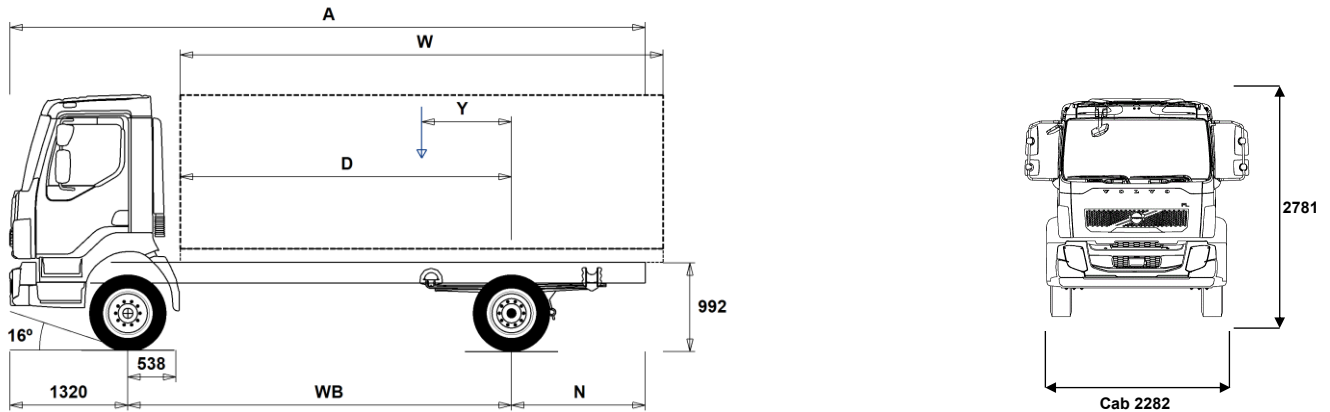

Chassis Dimensions [mm]

WB Wheelbase	3250	3500	3800	4100	4400	4700	5000	5300	5600	5900	6200	6500
A Overall Chassis Length	6545	6975	7425	7955	8425	8915	9435	9915	10425	10835	11430	11730
D Center of rear axle to front of body	2662	2912	3212	3512	3812	4112	4412	4712	5012	5312	5612	5912
N Rear Overhang (Min.)	1515	1685	1615	1515	1615	1615	1615	1615	1615	1615	1615	1615
N Rear Overhang (Max.)	1975	2155	2305	2535	2705	2895	3115	3295	3505	3615	3910	3910
Y Center of Gravity for Payload (Min.)	542	583	631	681	731	779	829	876	925	971	1022	1063
Y Center of Gravity for Payload (Max.)	741	798	865	935	1003	1071	1140	1207	1276	1342	1412	1474
W Body Length (Min.)	3842	4228	4693	5154	5617	6082	6544	7010	7473	7941	8400	8876
W Body Length (Max.)	4241	4659	5162	5661	6162	6666	7166	7672	8174	8681	9180	9697

Chassis Weights [kg]

Front Axle	3200	3205	3215	3220	3220	3230	3235	3250	3255	3265	3265	3285
Rear Axle	1385	1410	1440	1460	1475	1495	1515	1550	1565	1585	1605	1625
Kerb Weight	4585	4615	4655	4680	4695	4725	4750	4800	4820	4850	4870	4910
Payload (including body, driver, fuel, etc.)	11415	11385	11345	11320	11305	11275	11250	11200	11180	11150	11130	11090

Turning Diameter [mm]

Turning Circle Diameter Kerb to Kerb	11600	12400	13300	14200	15100	16000	16900	17800	18700	19600	20500	21400
Turning Circle Diameter Wall to Wall	12900	13700	14600	15500	16400	17300	18200	19100	20000	20900	21800	22700

Plated Weights [kg]

	Design
Gross Vehicle Weight	16000
Gross Combination Weight	21000
Front Axle	5800
Rear Axle	10900

Important Notes

Chassis Dimensions

Cab Height: +17 mm for CAB-CRW.
 Front Axle to Back of Cab: +1258 mm for CAB-CRW, +280 mm for CAB-SSLP.
 D-measure includes a front clearance of 50 mm and for rigid trucks also a subframe of 120 mm.
 Height can vary ± 20 mm for leaf and ± 10 mm for air suspension.
 All dimensions are for unladen chassis and any tag axles down. Chassis height used: CHH-MED.

Weight and dimensions are based upon the following tyres:
 Front Axle Tyres: 265/70R19.5
 Drive Axle Tyres: 265/70R19.5

Chassis weight includes oil, water, AdBlue, 0 litres fuel and without driver. Kerb weight can vary ± 3%.

Turning diameters are theoretically calculated.

Legal weights can differ from country to country.

For more detailed weight information, including optional equipment weights, ask your Volvo sales contact to enter your specification into the Volvo Weight Information system (WIS).

Do NOT use this drawing for bodybuilding. Refer to Volvo Bodybuilder Instructions and chassis assembly drawing FL42R816L.

MODEL RANGE

FL 42R GVW16 8L leaf FL 42 R 816L

Transport operation

- GARB-PRE** Refuse vehicle preparation
- UNIFORM** Basic platform vehicle

Core components

- CHH-HIGH** Chassis height high - approx. 1000 mm above ground level
- CHH-MED** Chassis height medium - approx. 900 mm above ground level
- RAD-L80** Rear leaf suspension - one axle, driving (80 mm wide leafs)
- FL-CREW2** FL Crew cab
- FL-DAY2** FL Day cab
- FL-SSLP2** FL Comfort cab
- EU6SCR** Euro 6 with SCR, particulate filter and EGR, Turbo-S
- D8K250** Diesel engine, Euro 6, 7.7 litres, 250 hp/184 kW, 950 Nm
- DBK280** Diesel engine, Euro 6, 7.7 litres, 280 hp/206 kW, 1050 Nm
- AL306** Automatic 6-speed gearbox, 1695 Nm
- ATO1056**
- EBR-CEB** Engine compression and exhaust brake
- EBR-EPG** Engine brake with exhaust pressure governor
- RSS1125A** Rear single reduction solo axle - axle load 11 tonnes, GCW 25 tonnes
- RSS1132A** Rear single reduction solo axle - axle load 11 tonnes, GCW 32.5 tonnes

Packages

- AUDIODAB** Audio system with DAB radio and DAB amplifier
- AUDIOPD** Preparation kit for DAB radio, including DAB amplifier

Chassis

- FST-PAR** Two-leaf front parabolic springs (normal stiffness)
- FST-PAR3** Three-leaf front parabolic springs (stiffer than normal)
- FAL5.8** Front axle load 5.8 tonnes
- FAL6.3** Front axle load 6.3 tonnes
- RAL10.9** Rear axle load 10.9 tonnes
- RSTAB1** Rear anti-roll bar, normal stiffness
- EBS-MED** EBS (Electronic Braking System), Medium package
- RST-PAR1** Rear parabolic leaf springs
- RST-PAR3** Three-leaf parabolic rear springs, stiffer than normal
- RST-PAR4** Short four-leaf parabolic rear springs with normal stiffness
- FST7070** Frame thickness - web 7.0 mm / flange 7.0 mm
- FST8080** Frame thickness - web 8.0 mm / flange 8.0 mm
- 2BATT170** Batteries, 2x170 Ah
- ADR2** ADR adaptation, 1 switch in dashboard, 1 outside on back of cab
- R80P** Right 80-litre plastic fuel tank
Min volume 80l
Max volume 430l
- UL-FUEL** Without left side fuel tank
Min volume 80l
Max volume 215l
- ADTP-L** AdBlue tank on left hand side
- ADTP-R** AdBlue tank on right hand side
- WHC-FIX1** One non-collapsible wheel chock
- WHC-FIX2** Two non-collapsible wheel chocks
- TOWMBRH** Towing member, high-mounted in centre of frame
- C-RO40AG** Towing coupling Rockinger 400 G-145
- TOWF-NO1** One front towing device
- TOWF-NO2** Two front towing devices
- TOWR-ONE** Rear towing device in frame-end cross member
- TREL15** 15-pin trailer connection (ADR certified)
- TBC-EC** Trailer brake connection, European Community

Standard Equipment

Optional Equipment

For more detailed information about cab and powertrain equipment, please refer to separate specification sheets.

For all possible options and combinations of options please consult your Volvo sales contact who can create a specification to match your requirements using the Volvo Sales Support system (VSS).

The factory reserves the right to modify design and change equipment without previous notification. The specification can vary from country to country.

RUP-FIX2

- RFEND-T** Transport mudguard

Rims and tyres

- RT-AL** Brushed aluminium rims with standard holes (long stud fixing) on all axles
- RT-ALDP** Dura-Bright® polished aluminium rims with standard holes (long stud fixing) on all axles
- RT-STEEL** Steel rims on all axles
- SPWT-F** Spare front wheel
- SWCP-LF** Spare wheel carrier on left side in front of rear axle
- SWCP-R** Spare wheel carrier mounted behind rear axle
- SWCP-TP** Spare wheel and carrier transport-mounted on top of frame
- JACK-10T** Hydraulic jack, 10 tonnes. Low manual pumping force facilitates use in uncomfortable positions. Has a release valve, which permits safe, easy and precise control over rate of lowering and a filter in the oil reservoir gives protection from contamination. Colour RAL 9004. Height 200-518 mm, weight 9,2 kg
- JACK-8T** Hydraulic jack, 8 tonnes. Low manual pumping force facilitates use in uncomfortable positions. Has a release valve, which permits safe, easy and precise control over rate of lowering and a filter in the oil reservoir gives protection from contamination. Colour RAL 9004. Height 227-469 mm, weight 7.3 kg
- GAUGE-TP** Tyre pressure gauge

Powertrain equipment

- CS39A-O** Single-plate clutch, plate diameter 395 mm
- RET-TPT** Gearbox-mounted Powertronic primary retarder
- TC-HWO** Oil cooler for hydraulic transmissions – water/oil
- 1COMP500** Single-cylinder air compressor 360 cc, 500 l/min
- 2COM1080** Dual-cylinder air compressor 704 cc, 1080 l/min
- AIRIN-HI** High air inlet
- AIRIN-RL** Low air inlet, chassis mounted behind cab on left-hand side
- ACL1ST** Air cleaner with one filter element
- ACL1ST-S** Air cleaner with extra filter element
- 24AL110B** Alternator 110 Ampere
- 24AL130B** Alternator 130 Ampere
- CCV-C** Closed crankcase ventilation
- CCV-OX** Open extended crankcase ventilation with oil separator and maintenance-free gas centrifuge
- EST-AID** Engine intake air heater
- PTER-100** Rear engine, clutch-independent PTO, flange connection, DIN 100/ISO 7646
- PTER-DIN** Rear engine, clutch-ind. PTO, splined shaft groove (fem), close-coupled pump DIN 5462/ISO7653
- PTER1400** Rear engine, clutch-independent PTO, flange connection, SAE 1410/ISO 7647
- PR-HF4S** Rear gearbox (side) PTO, flange connection
- PR-HF4SH** Rear gearbox (side) PTO, flange connection, high-speed
- PR-HF6S** Rear gearbox (side) PTO, flange connection
- PR-HP4S** Preparation kit for rear, side-mounted gearbox PTO, pump connection, 400 Nm
- PR-HP4SH** Rear gearbox PTO, pump connection, side-mounted, high-speed
- PR-HP6S** Preparation kit for rear, side-mounted gearbox PTO, pump connection, 600 Nm
- PTR-FH1** Rear gearbox PTO with flange connection DIN 90/ISO 7646 for propshaft 800 Nm
- PTR-FH2** Rear gearbox PTO with flange connection DIN 90/ISO 7646 for propshaft, 430 Nm
- PTR-FH5** Rear gearbox PTO with flange connection DIN 90/ISO 7646 for propshaft, 450 Nm
- PTR-PH1** Rear gearbox PTO Hydrocar S81, connection DIN 5462/ISO 7653 for pump, 800 Nm

MODEL RANGE

FL 42R GVW16 8L leaf FL 42 R 816L

- **PTR-PH2** Rear gearbox PTO Hydrocar S84, connection DIN 5462/ISO 765 for pump, 430 Nm
- **PTR-PH4** Rear gearbox PTO Hydrocar S88, connection DIN 5462/ISO 7653 for pump, 450 Nm
- **PTR-PK** Preparation kit for rear gearbox PTO
- **PTR-ZF2** Rear gearbox PTO ZF, flange connection DIN 100/ISO 7646 for propshaft, 410 Nm
- **PTR-ZF3** Rear gearbox PTO ZF, connection DIN 5462/ISO 7653 for pump, 410 Nm
- **PTR-ZF4** Rear gearbox PTO ZF, flange connection DIN 100/ISO 7646 for propshaft, 320 Nm
- **PTR-ZF5** Rear gearbox PTO ZF, connection DIN 5462/ISO 7653 for pump, 320 Nm
- **PTR-ZF6** Rear gearbox PTO ZF, flange connection DIN 100/ISO 7646 for propshaft, 270 Nm

- **HPG-F101** Gearbox-mounted hydraulic pump F1-101, fixed displacement, single flow
- **HPG-F41** Gearbox-mounted hydraulic pump F1-41, fixed displacement, single flow
- **HPG-F51** Gearbox-mounted hydraulic pump F1-51, fixed displacement, single flow
- **HPG-F61** Gearbox-mounted hydraulic pump F1-61, fixed displacement, single flow
- **HPG-F81** Gearbox-mounted hydraulic pump F1-81, fixed displacement, single flow

- **ETC** PTO speed control 900-1500 rpm with dash-mounted switch

Cab interior

- **TAS-DIG4** Gen 4 one-day digital tachograph, EC approved (GNSS & DSRC, EU 2020/1054)
- **TSRS2** Road sign recognition (not ISA compliant)
- **SPDU-R** Dual speed limiter for refuse truck, rear loader

Cab exterior

- **SUNV-B** Exterior front sun visor, transparent dark-grey
- **AD-SIDES** Cab side air deflectors, short
- **BEACON-P** Preparation kit for roof beacons
- **BEACONA2** Two amber LED beacons on cab front roof

Superstructure preparations

- **FBA-BTF** Front body attachment brackets, lower, for flexible body
- **FBA-BTSF** Front body attachment brackets, lower, for semi-flexible body
- **RBA-T2** Rear body attachment brackets, lower
- **TAILPREP** Tail lift preparation kit

Services

- **TGW-4G**