

MODEL RANGE

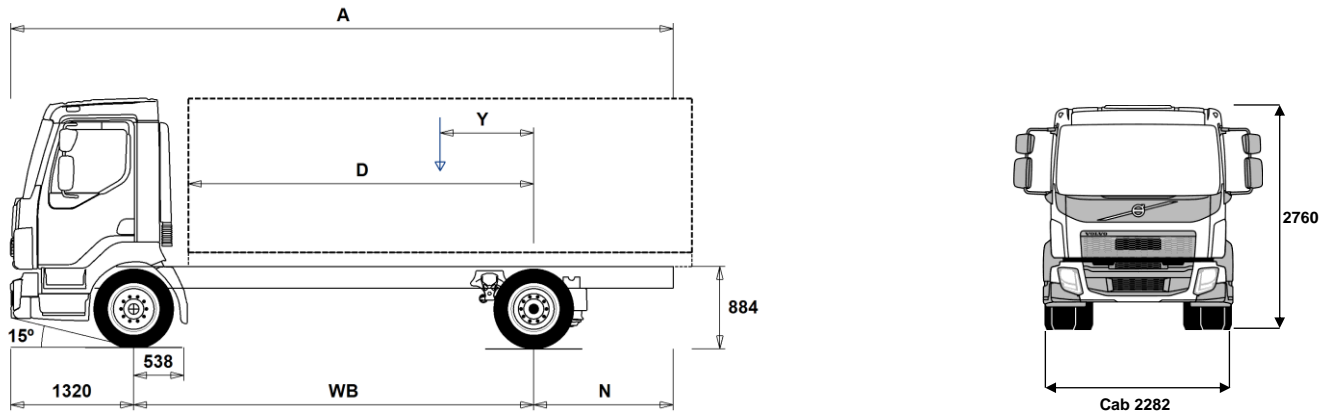

Volvo Trucks. Driving Progress

FL816 4x2 Platform 16 tonne - Rear Air Suspension FL 42 R 816A



Chassis Dimensions [mm]

WB Wheelbase	3500	3800	4100	4400	4700	5000	5300	5600	5900	6200	6500
A Overall Chassis Length	6975	7425	7955	8425	8915	9435	9915	10425	10835	11430	11730
D Center of rear axle to front of body	2912	3212	3512	3812	4112	4412	4712	5012	5312	5612	5912
N Rear Overhang (Min.)	1685	1885	2805	2255	2485	2685	2895	3095	3295	3505	3755
N Rear Overhang (Max.)	2155	2305	2535	2705	2895	3115	3295	3505	3615	3910	3910
Y Center of Gravity for Payload (Min.)	642	699	758	817	874	932	990	1048	1102	1161	1215
Y Center of Gravity for Payload (Max.)	642	699	758	817	874	932	990	1048	1102	1161	1215

Chassis Weights [kg]

Front Axle	3185	3185	3180	3175	3180	3180	3180	3185	3195	3195	3200
Rear Axle	1355	1390	1415	1440	1470	1500	1525	1550	1585	1610	1620
Kerb Weight	4540	4575	4595	4615	4650	4680	4705	4735	4780	4805	4820
Payload (including body, driver, fuel, etc.)	9900	9865	9845	9825	9790	9760	9735	9705	9660	9635	9620

Turning Diameter [mm]

Turning Circle Diameter Kerb to Kerb	12400	13300	14200	15100	16000	16900	17800	18700	19600	20500	21400
Turning Circle Diameter Wall to Wall	13700	14600	15500	16400	17300	18200	19100	20000	20900	21800	22700

Plated Weights [kg]

	Plated	Design
Gross Vehicle Weight	14440	16000
Gross Combination Weight	21000	21000
Front Axle	5000	5800
Rear Axle	9440	10900

Important Notes

Chassis Dimensions

Cab Height: +39 mm for CAB-CRW.
 Front Axle to Back of Cab: +1302 mm for CAB-CRW, +294 mm for CAB-SSLP.
 D-measure includes a front clearance of 50 mm and for rigid trucks also a subframe of 120 mm.
 Height can vary ± 20 mm for leaf and ± 10 mm for air suspension.
 All dimensions are for unladen chassis and any tag axles down.

Weight and dimensions are based upon the following tyres:
 Front Axle Tyres: 265/70R19.5
 Drive Axle Tyres: 265/70R19.5

Chassis weight includes oil, water, AdBlue, 0 litres fuel and without driver. Kerb weight can vary $\pm 3\%$.

Turning diameters are theoretically calculated.

Legal weights can differ from country to country.

For more detailed weight information, including optional equipment weights, ask your Volvo sales contact to enter your specification into the Volvo Weight Information system (WIS).

Do NOT use this drawing for bodybuilding. Refer to Volvo Bodybuilder Instructions and chassis assembly drawing FL42R816A.

MODEL RANGE

FL816 4x2 Platform 16 tonne - Rear Air Suspension FL 42 R 816A

CORE COMPONENTS

- **CHH-MED** Chassis Height - Medium - for loading heights check the unique BEP chassis drawing
- **RAD-A2V** Two bag rear air suspension
- **CAB-CRW** Cab - Four-door - Six seater crewcab
Designed and built to Swedish impact and ECE R29 regulations
- **CAB-DAY** Cab - Day - with steel safety cage design.
Designed and built to Swedish impact and ECE R29 regulations
- **CAB-SSLP** Cab - Comfort with additional storage space or optional fold up bunk behind the driver - with steel safety cage design.
Designed and built to Swedish impact and ECE R29 regulations.
- **EU6SCR** Emission level - Euro VI step D
- **D8K250** Engine - D8K250 six-cylinder 7.7 litre developing 250hp at 2100rpm.
Peak torque 950Nm at 900-1700rpm.
- **D8K280** Engine - D8K280 six-cylinder 7.7 litre developing 280hp at 2100rpm.
Peak torque 1050Nm at 950-1700rpm.
- **AL306** Gearbox - Allison AL306 6-speed automatic gearbox
If a PTO is required it must be specified from the factory
- **ATO1056** Gearbox - Automated 6-speed I-sync overdrive
- **ZTO1006** Gearbox - Manual 6-speed overdrive
- **EBR-CEB** Engine Brake Type - Compression - producing 170kW at 2800rpm
- **EBR-EPG** Engine Brake Type - Exhaust - producing 120kW at 2800rpm
- **RSS1125A** Drive Axle - RS1125A single reduction with differential lock - design GCW 25tonne
- **RSS1132A** Drive Axle - RS1132A single reduction with differential lock - design GCW 32tonne

Packages

- **DRIVEFL** Cab Package - Drive
- **VISIFL** Visibility Package -
- **AIRFLOW** Airflow Package -
- **AUDIODAB** Audio System - Digital DAB AM/FM Radio with Bluetooth - without CD player
- **AUDIOPPD** Audio - Preparation for DAB radio including amplifier and aerial

CHASSIS

- **FST-AIR** Front suspension type - Air
- **FST-PAR** Front suspension type - Parabolic front springs with shock absorbers and anti-roll bar
- **FAL5.8** Front axle design capacity - 5.8 tonne
- **RAL10.9** Rear Axle Design Capacity - 10.9 tonne
- **EBS-MED** Brake package - EBS medium including traction control & hill hold
- **EBS-STD** Brake package - EBS standard package without traction control
- **RST-AIR** Rear suspension type - Air
- **SUSPL-E1** Air suspension levelling control - Remote control on wander-lead
- **SUSPL-E2** Air suspension levelling control - Remote control on wander-lead
- **SUSPL-E3** Air suspension levelling control - Integral dash switches
- **FST7070** Chassis frame thickness - 7 mm web and flange
- **FST8080** Chassis frame thickness - 8 mm web and flange
- **2BATT170** Battery Capacity - 2 x 170 Ah on the left-hand side
- **ADR2** ADR Adaptation - For transportation of dangerous goods on the road - Note does NOT include safe loading pass package if required this is quoted separately
- **R215P** Right fuel tank - 215-litre plastic

■ Standard Equipment

□ Optional Equipment

For more detailed information about cab and powertrain equipment, please refer to separate specification sheets.

For all possible options and combinations of options please consult your Volvo sales contact who can create a specification to match your requirements using the Volvo Sales Support system (VSS).

The factory reserves the right to modify design and change equipment without previous notification. The specification can vary from country to country.

- Min volume 80l
Max volume 430l
- **UL-FUEL** Without left fuel tank
Min volume 80l
Max volume 215l
- **ADTP-L** Adblue tank position - Chassis mounted on the left-hand side
- **ADTP-R** Adblue tank position - Chassis mounted on the right-hand side
- **WHC-FIX1** Wheel chock - One fixed design
- **WHC-FIX2** Wheel chocks - Two fixed design
- **TOWMBRH** Tow member - High mounted in centre of frame - Check the GCW in the "Truck Use" section of this specification
- **C-RO40AG** Drawbar coupling - Rockinger 400 G145
- **TOWF-NO1** Front towing device - One pin in bumper
- **TOWF-NO2** Front towing device - Two pins in bumper
- **TOWR-ONE** Light trailer coupling - Pintle type hitch attached to rear cross member for an unbraked trailer
- **TREL15** Trailer electrical connection - Single 15 pin - ADR certified
- **TBC-EC** Trailer brakes with EC palm coupling connectors
- **RUP-FIX2** Rear underrun protection - Fixed EC approved
- **RFEND-T** Rear mud wings - Temporary on drive axle for transport delivery only

WHEELS & TYRES

- **RT-AL** Wheels - Alcoa brushed aluminium rims - standard holes for long stud fixing
- **RT-ALDP** Wheels - Alcoa Dura-Bright aluminium rims - standard holes for long stud fixing
- **RT-STEEL** Wheels - Steel rims
- **SPWT-F** Spare wheel & tyre - Spare with front tyre pattern
- **SWCP-LF** Spare wheel carrier on left side of chassis ahead of rear axle
- **SWCP-R** Spare wheel carrier rear mounted below frame.
- **SWCP-T** Spare wheel supplied temporarily strapped to chassis
- **SWCP-TP** Spare wheel carrier transport mounted on frame (spare wheel carrier not included)
- **JACK-8T** 8 tonne bottle jack
- **GAUGE-TP** Tyre pressure gauge

DRIVELINE EQUIPMENT

- **CS39A-O** Clutch - Single plate 395mm (16")
- **RET-TPT** Retarder for automatic gearbox
- **TC-HWO** Transmission oil cooler - water to oil
- **2COM1080** Air compressor - Two-cylinder 1080 litres per minute
- **AIRIN-HI** Air intake - Mounted behind cab on the left-hand side
- **AIRIN-RL** Air intake - Chassis mounted behind cab on the left-hand side
- **ACL1ST** Air filter - Single element
- **ACL1ST-S** Air filter - two-stage element
- **24AL110B** Alternator capacity - 110 amp
- **24AL130B** Alternator capacity - 130 amp
- **CCV-C** Closed crankcase ventilation
- **CCV-OX** Open crankcase ventilation with oil separator and a maintenance free gas centrifuge
- **EST-AID** Engine starting aid -Preheating element in the air inlet manifold
- **PTER-100** Engine power-take-off - Rear-mounted with DIN100/ISO7646 flange
- **PTER-DIN** Engine power-take-off - Rear-mounted with DIN5462 (female) splined shaft for a close-coupled pump
- **PTER1400** Engine power-take-off - Rear-mounted with SAE 1410 flange
- **PR-HF4S** Live-drive PTO for Allison gearbox output 400Nm for flange connection
mounted on the side of the torque convertor

MODEL RANGE

FL816 4x2 Platform 16 tonne - Rear Air Suspension FL 42 R 816A

- PR-HF4SH** Live-drive high speed PTO for Allison gearbox output 400Nm for hydraulic pump connection mounted on the side of the torque convertor
- PR-HF6S** Live-drive PTO for Allison gearbox output 600Nm for flange connection mounted on the side of the torque convertor
- PR-HP4S** Live-drive PTO for Allison gearbox output 400Nm for hydraulic pump connection mounted on the side of the torque convertor
- PR-HP4SH** Live-drive high speed PTO for Allison gearbox output 400Nm for hydraulic pump connection mounted on the side of the torque convertor
- PR-HP6S** Live-drive PTO for Allison gearbox output 600Nm for hydraulic pump connection mounted on the side of the torque convertor
- PTR-FH1** Rear PTO Gearbox S81 flange DIN connection
- PTR-FH2** Rear PTO Gearbox S84 flange DIN connection
- PTR-FH5** Rear PTO Gearbox S88 flange DIN connection
- PTR-PH1** Rear PTO Gearbox S81 pump DIN connection
- PTR-PH2** Rear PTO Gearbox S84 pump DIN connection
- PTR-PH4** Rear PTO Gearbox S88 pump DIN connection
- PTR-PK** Electrical and solenoid prep kit for gearbox PTO
- PTR-ZF2** Rear Power Take Off flange DIN connection
- PTR-ZF3** Rear Power Take Off Gearbox pump DIN connection
- PTR-ZF4** Rear PTO Gearbox 320Nm flange connection
- PTR-ZF5** Rear PTO Gearbox 320Nm pump connection
- PTR-ZF6** Rear PTO Gearbox 320Nm flange connection
- HPG-F101** Gearbox mounted hydraulic pump F1-101, fixed displacement, single flow.
- HPG-F41** Gearbox mounted hydraulic pump F1-41, fixed displacement, single flow.
- HPG-F51** Gearbox mounted hydraulic pump F1-51, fixed displacement, single flow.
- HPG-F61** Gearbox mounted hydraulic pump F1-61, fixed displacement, single flow.
- HPG-F81** Gearbox mounted hydraulic pump F1-81, fixed displacement, single flow.
- ETC** Electronic throttle control - dash mounted switch for PTO speed control

CAB INTERIOR

- STWPOS-R** Steering wheel position - RIGHT-HAND DRIVE

CAB EXTERIOR

- SUNV-B** Exterior sun visor - Smoked grey
- SUNV-PK** Exterior sun visor preparation kit only
- AD-SIDES** Cab side air deflector, short extension panels.
- BEACON-P** Roof beacons - wiring preparation only
- BEACONA2** Two amber beacons directly mounted to cab roof

SUPERSTRUCTURE PREPARATIONS

- PCA90191**
- FBA-BTF** Lower front body attachments - For torsionally flexible - platform body
- FBA-BTSF** Lower front body attachments - For torsionally semi-flexible body - box or curtainsider
- RBA-T2** Rear body attachments - Divided
- TAILPREP** Taillift preparation kit - cab switch and warning in driver display

DELIVERY SERVICES

- TGW-4G** Telematics gateway - GSM/GPRS/4G modem, WLAN
- WVTA** EC Whole Vehicle Type Approved

VOLVO

Volvo Truck Corporation
volvotrucks.com