

MODEL RANGE

FL 42R GVW14 8L air FL 42 R 814A

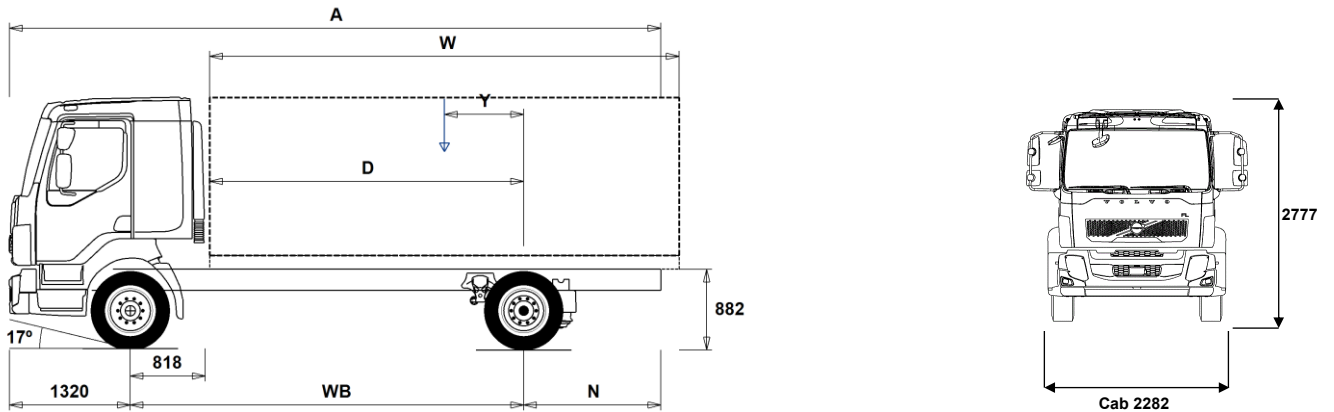

Chassis Dimensions [mm]

WB Wheelbase	3500	3800	4100	4400	4700	5000	5300	5600	5900	6200	6500
A Overall Chassis Length	6975	7425	7955	8425	8915	9435	9915	10425	10835	11430	11730
D Center of rear axle to front of body	2632	2932	3232	3532	3832	4132	4432	4732	5032	5332	5632
N Rear Overhang (Min.)	1685	1885	2085	2255	2485	2685	2895	3095	3295	3505	3755
N Rear Overhang (Max.)	2155	2305	2535	2705	2895	3115	3295	3505	3615	3910	3910
Y Center of Gravity for Payload (Min.)	465	504	545	585	623	662	701	740	774	814	850
Y Center of Gravity for Payload (Max.)	653	709	766	823	878	934	990	1047	1098	1156	1208
W Body Length (Min.)	3958	4447	4932	5419	5907	6395	6884	7371	7867	8353	8847
W Body Length (Max.)	4334	4856	5375	5895	6417	6940	7462	7983	8516	9036	9532

Chassis Weights [kg]

Front Axle	3260	3270	3270	3270	3275	3285	3290	3290	3305	3310	3315
Rear Axle	1420	1445	1465	1480	1505	1530	1550	1565	1595	1615	1620
Kerb Weight	4680	4715	4735	4750	4780	4815	4840	4855	4900	4925	4935
Payload (including body, driver, fuel, etc.)	9320	9285	9265	9250	9220	9185	9160	9145	9100	9075	9065

Turning Diameter [mm]

Turning Circle Diameter Kerb to Kerb	12400	13300	14200	15100	16000	16900	17800	18700	19600	20500	21400
Turning Circle Diameter Wall to Wall	13700	14600	15500	16400	17300	18200	19100	20000	20900	21800	22700

Plated Weights [kg]

	Design
Gross Vehicle Weight	14000
Gross Combination Weight	15500
Front Axle	5000
Rear Axle	9500

Important Notes

Chassis Dimensions

Cab Height: +17 mm for CAB-CRW.
 Front Axle to Back of Cab: +978 mm for CAB-CRW, -280 mm for CAB-DAY.
 D-measure includes a front clearance of 50 mm and for rigid trucks also a subframe of 120 mm.
 Height can vary ± 20 mm for leaf and ± 10 mm for air suspension.
 All dimensions are for unladen chassis and any tag axles down.

Weight and dimensions are based upon the following tyres:
 Front Axle Tyres: 265/70R19.5
 Drive Axle Tyres: 265/70R19.5

Chassis weight includes oil, water, AdBlue, 0 litres fuel and without driver. Kerb weight can vary ± 3%.

Turning diameters are theoretically calculated.

Legal weights can differ from country to country.

For more detailed weight information, including optional equipment weights, ask your Volvo sales contact to enter your specification into the Volvo Weight Information system (WIS).

Do NOT use this drawing for bodybuilding. Refer to Volvo Bodybuilder Instructions and chassis assembly drawing FL42R814A.

MODEL RANGE

FL 42R GVW14 8L air FL 42 R 814A

Core components

- **CHH-MED** Chassis height medium - approx. 900 mm above ground level
- **RAD-A2V** Rear air suspension - one axle, driving
- **FL-CREW2** FL Crew cab
- **FL-DAY2** FL Day cab
- **FL-SSLP2** FL Comfort cab
- **EU6SCR** Euro 6 with SCR, particulate filter and EGR, Turbo-S
- **D8K250** Diesel engine, Euro 6, 7.7 litres, 250 hp/184 kW, 950 Nm
- **D8K280** Diesel engine, Euro 6, 7.7 litres, 280 hp/206 kW, 1050 Nm
- **AL306** Automatic 6-speed gearbox, 1695 Nm
- **ATO1056**
- **ZTO1006** Manual 6-speed gearbox, 1050 Nm
- **EBR-CEB** Engine compression and exhaust brake
- **EBR-EPG** Engine brake with exhaust pressure governor
- **RSS1125A** Rear single reduction solo axle - axle load 11 tonnes, GCW 25 tonnes
- **RSS1132A** Rear single reduction solo axle - axle load 11 tonnes, GCW 32.5 tonnes

Packages

- **AUDIODAB** Audio system with DAB radio and DAB amplifier
- **AUDIOPD** Preparation kit for DAB radio, including DAB amplifier

Chassis

- **FST-AIR** Front air suspension
- **FST-PAR** Two-leaf front parabolic springs (normal stiffness)
- **FAL5.0** Front axle load 5.0 tonnes
- **FAL5.8** Front axle load 5.8 tonnes
- **RAL9.5** Rear axle load 9.5 tonnes
- **EBS-MED** EBS (Electronic Braking System), Medium package
- **RST-AIR** Rear air springs
- **SUSPL-E1** Remote control with wander lead for air suspension levelling, 1 sensor on rear axle
- **SUSPL-E2** Remote control with wander lead for air suspension levelling, 2 sensors on rear axle
- **SUSPL-E3** Three dashboard switches for air suspension levelling, 1 sensor on rear axle
- **FST6060** Frame thickness - web 6.0 mm / flange 6.0 mm
- **FST7070** Frame thickness - web 7.0 mm / flange 7.0 mm
- **FST8080** Frame thickness - web 8.0 mm / flange 8.0 mm
- **2BATT170** Batteries, 2x170 Ah
- **ADR2** ADR adaptation, 1 switch in dashboard, 1 outside on back of cab
- **R80P** Right 80-litre plastic fuel tank
Min volume 80l
Max volume 430l
- **UL-FUEL** Without left side fuel tank
Min volume 80l
Max volume 215l
- **ADTP-L** AdBlue tank on left hand side
- **ADTP-R** AdBlue tank on right hand side
- **WHC-FIX1** One non-collapsible wheel chock
- **WHC-FIX2** Two non-collapsible wheel chocks
- **TOWMBRH** Towing member, high-mounted in centre of frame
- **C-RO40AG** Towing coupling Rockinger 400 G-145
- **TOWF-NO1** One front towing device
- **TOWF-NO2** Two front towing devices
- **TOWR-ONE** Rear towing device in frame-end cross member
- **TREL15** 15-pin trailer connection (ADR certified)
- **TBC-EC** Trailer brake connection, European Community

□ RUP-FIX2

- **RFEND-T** Transport mudguard

Rims and tyres

- **RT-AL** Brushed aluminium rims with standard holes (long stud fixing) on all axles
- **RT-ALDP** Dura-Bright® polished aluminium rims with standard holes (long stud fixing) on all axles
- **RT-STEEL** Steel rims on all axles
- **SPWT-F** Spare front wheel
- **SWCP-LF** Spare wheel carrier on left side in front of rear axle
- **SWCP-R** Spare wheel carrier mounted behind rear axle
- **SWCP-TP** Spare wheel and carrier transport-mounted on top of frame
- **JACK-8T** Hydraulic jack, 8 tonnes. Low manual pumping force facilitates use in uncomfortable positions. Has a release valve, which permits safe, easy and precise control over rate of lowering and a filter in the oil reservoir gives protection from contamination. Colour RAL 9004. Height 227-469 mm, weight 7.3 kg
- **GAUGE-TP** Tyre pressure gauge

Powertrain equipment

- **CS39A-O** Single-plate clutch, plate diameter 395 mm
- **RET-TPT** Gearbox-mounted Powertronic primary retarder
- **TC-HWO** Oil cooler for hydraulic transmissions – water/oil
- **1COMP500** Single-cylinder air compressor 360 cc, 500 l/min
- **2COM1080** Dual-cylinder air compressor 704 cc, 1080 l/min
- **AIRIN-HI** High air inlet
- **AIRIN-RL** Low air inlet, chassis mounted behind cab on left-hand side
- **ACL1ST** Air cleaner with one filter element
- **ACL1ST-S** Air cleaner with extra filter element
- **24AL110B** Alternator 110 Ampere
- **24AL130B** Alternator 130 Ampere
- **CCV-C** Closed crankcase ventilation
- **CCV-OX** Open extended crankcase ventilation with oil separator and maintenance-free gas centrifuge
- **EST-AID** Engine intake air heater
- **PTER-100** Rear engine, clutch-independent PTO, flange connection, DIN 100/ISO 7646
- **PTER-DIN** Rear engine, clutch-ind. PTO, splined shaft groove (fem), close-coupled pump DIN 5462/ISO7653
- **PTER1400** Rear engine, clutch-independent PTO, flange connection, SAE 1410/ISO 7647
- **PR-HF4S** Rear gearbox (side) PTO, flange connection
- **PR-HF4SH** Rear gearbox (side) PTO, flange connection, high-speed
- **PR-HF6S** Rear gearbox (side) PTO, flange connection
- **PR-HP4S** Preparation kit for rear, side-mounted gearbox PTO, pump connection, 400 Nm
- **PR-HP4SH** Rear gearbox PTO, pump connection, side-mounted, high-speed
- **PR-HP6S** Preparation kit for rear, side-mounted gearbox PTO, pump connection, 600 Nm
- **PTR-FH1** Rear gearbox PTO with flange connection DIN 90/ISO 7646 for propshaft 800 Nm
- **PTR-FH2** Rear gearbox PTO with flange connection DIN 90/ISO 7646 for propshaft, 430 Nm
- **PTR-FH5** Rear gearbox PTO with flange connection DIN 90/ISO 7646 for propshaft, 450 Nm
- **PTR-PH1** Rear gearbox PTO Hydrocar S81, connection DIN 5462/ISO 7653 for pump, 800 Nm
- **PTR-PH2** Rear gearbox PTO Hydrocar S84, connection DIN 5462/ISO 765 for pump, 430 Nm
- **PTR-PH4** Rear gearbox PTO Hydrocar S88, connection DIN 5462/ISO 7653 for pump, 450 Nm
- **PTR-PK** Preparation kit for rear gearbox PTO
- **PTR-ZF2** Rear gearbox PTO ZF, flange connection DIN 100/ISO 7646 for propshaft, 410 Nm

■ Standard Equipment □ Optional Equipment

For more detailed information about cab and powertrain equipment, please refer to separate specification sheets.

For all possible options and combinations of options please consult your Volvo sales contact who can create a specification to match your requirements using the Volvo Sales Support system (VSS).

The factory reserves the right to modify design and change equipment without previous notification. The specification can vary from country to country.

MODEL RANGE

FL 42R GVW14 8L air FL 42 R 814A

- **PTR-ZF3** Rear gearbox PTO ZF, connection DIN 5462/ISO 7653 for pump, 410 Nm
- **PTR-ZF4** Rear gearbox PTO ZF, flange connection DIN 100/ISO 7646 for propshaft, 320 Nm
- **PTR-ZF5** Rear gearbox PTO ZF, connection DIN 5462/ISO 7653 for pump, 320 Nm
- **PTR-ZF6** Rear gearbox PTO ZF, flange connection DIN 100/ISO 7646 for propshaft, 270 Nm
- **HPG-F101** Gearbox-mounted hydraulic pump F1-101, fixed displacement, single flow
- **HPG-F41** Gearbox-mounted hydraulic pump F1-41, fixed displacement, single flow
- **HPG-F51** Gearbox-mounted hydraulic pump F1-51, fixed displacement, single flow
- **HPG-F61** Gearbox-mounted hydraulic pump F1-61, fixed displacement, single flow
- **HPG-F81** Gearbox-mounted hydraulic pump F1-81, fixed displacement, single flow
- **ETC** PTO speed control 900-1500 rpm with dash-mounted switch

Cab interior

- **TAS-DIG4** Gen 4 one-day digital tachograph, EC approved (GNSS & DSRC, EU 2020/1054)
- **TSRS2** Road sign recognition (not ISA compliant)

Cab exterior

- **SUNV-B** Exterior front sun visor, transparent dark-grey
- **AD-SIDES** Cab side air deflectors, short
- **BEACON-P** Preparation kit for roof beacons
- **BEACONA2** Two amber LED beacons on cab front roof

Superstructure preparations

- **FBA-BTF** Front body attachment brackets, lower, for flexible body
- **FBA-BTSF** Front body attachment brackets, lower, for semi-flexible body
- **RBA-T2** Rear body attachment brackets, lower
- **TAILPREP** Tail lift preparation kit

Services

- **TGW-4G**