

MODEL RANGE

FL514 4x2 Rigid 14 tonne - Steel Suspension FL 42 R 514L

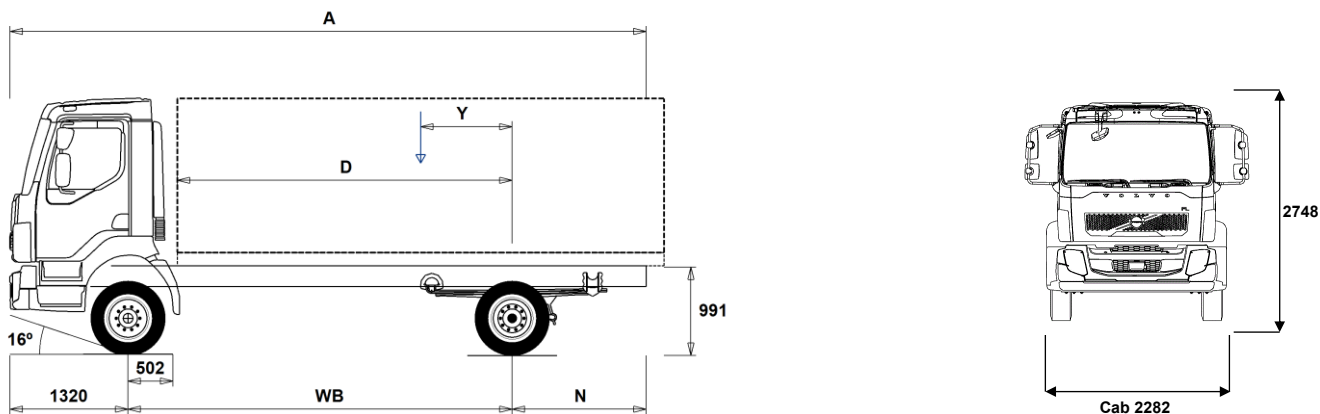

Chassis Dimensions [mm]

WB Wheelbase	3250	3500	3800	4100	4400	4700	5000	5300	5600	5900	6200	6500
A Overall Chassis Length	6545	6975	7425	7955	8425	8915	9435	9915	10425	10835	11430	11730
D Center of rear axle to front of body	2698	2948	3248	3548	3848	4148	4448	4748	5048	5348	5648	5948
N Rear Overhang (Min.)	1885	2055	1855	2445	2635	2835	2895	2895	3415	3295	3505	3755
N Rear Overhang (Max.)	1975	2155	2305	2535	2705	2895	3115	3295	3505	3615	3910	3910
Y Center of Gravity for Payload (Min.)	530	575	630	685	741	794	848	903	958	1006	1063	1112
Y Center of Gravity for Payload (Max.)	530	575	630	685	741	794	848	903	958	1006	1063	1112

Chassis Weights [kg]

Front Axle	3065	3060	3055	3045	3040	3040	3040	3035	3035	3045	3040	3050
Rear Axle	1235	1275	1310	1335	1360	1390	1425	1450	1470	1500	1530	1540
Kerb Weight	4300	4335	4365	4380	4400	4430	4465	4485	4505	4545	4570	4590
Payload (including body, driver, fuel, etc.)	8660	8625	8595	8580	8560	8530	8495	8475	8455	8415	8390	8370

Turning Diameter [mm]

Turning Circle Diameter Kerb to Kerb	11600	12400	13300	14200	15100	16000	16900	17700	18600	19500	20400	21300
Turning Circle Diameter Wall to Wall	12900	13700	14600	15500	16400	17300	18200	19100	20000	20900	21800	22700

Plated Weights [kg]

	Plated	Design
Gross Vehicle Weight	12960	14000
Gross Combination Weight	0	19500
Front Axle	4480	5000
Rear Axle	8480	9500

Important Notes

Chassis Dimensions

Cab Height: +39 mm for CAB-CRW.

Front Axle to Back of Cab: +1294 mm for CAB-CRW, +316 mm for CAB-SSLP.

D-measure includes a front clearance of 50 mm and for rigid trucks also a subframe of 120 mm.

Height can vary ± 20 mm for leaf and ± 10 mm for air suspension.

All dimensions are for unladen chassis and any tag axles down. Chassis height used: CHH-MED.

Weight and dimensions are based upon the following tyres:

Front Axle Tyres: 245/70R19.5

Drive Axle Tyres: 245/70R19.5

Chassis weight includes oil, water, AdBlue, 0 litres fuel and without driver. Kerb weight can vary ± 3%.

Turning diameters are theoretically calculated.

Legal weights can differ from country to country.

For more detailed weight information, including optional equipment weights, ask your Volvo sales contact to enter your specification into the Volvo Weight Information system (WIS).

Do NOT use this drawing for bodybuilding. Refer to Volvo Bodybuilder Instructions and chassis assembly drawing FL42R514L.

MODEL RANGE

FL514 4x2 Rigid 14 tonne - Steel Suspension FL 42 R 514L

CORE COMPONENTS

- CHH-HIGH** Chassis height - High - for loading heights check the unique BEP chassis drawing attached to this quote
- CHH-MED** Chassis height - Medium - for loading heights check the unique BEP chassis drawing attached to this quote
- RAD-L80** Rear suspension - 80mm parabolic rear springs
- FL-CREW2** Cab - Four door six person crew cab
- FL-DAY2** Cab - Day, with steel safety cage design. Designed and built to Swedish impact and ECE R29 regulations
- FL-SSLP2** Cab - Comfort with additional storage space or optional fold up bunk behind the driver - with steel safety cage design. Designed and built to Swedish impact and ECE R29 regulations.
- EU6SCR** Emission level - Euro VI step E
- D5K210** Engine - D5K210 four-cylinder 5.1 litre developing 210hp at 2200rpm.
Peak torque 800Nm at 1100-1700rpm.
- D5K240** Engine - D5K240 four-cylinder 5.1 litre developing 240hp at 2200rpm.
Peak torque 900Nm at 1100-1600rpm.
- ATO1056** Gearbox - Automated 6-speed I-sync overdrive - if the truck is built from week 47 an 8 speed ZF powerline automatic.
- ATO8006** Gearbox - Automated 6-speed I-sync overdrive - if the truck is built from week 47 an 8 speed ZF powerline automatic.
- STO8006** Gearbox - Manual 6-speed overdrive
- ZTO1006** Gearbox - Manual 6-speed overdrive
- EBR-EPG** Engine brake type - Exhaust brake controlled by steering column switch
- RSS1125A** Drive axle - RS1125A single reduction with differential lock Design GCW 25tonne
- RSS1132A** Drive axle - RS1132A single reduction with differential lock Design GCW 32tonne

Packages

- DRIVEFL** Cab Package - Drive
- VISIFL** Visibility package
- AIRFLOW** Airflow Package
- AUDIODAB** Audio System - Digital DAB AM/FM Radio with Bluetooth - without CD player
- AUDIOPD** Audio - Preparation for DAB radio including amplifier and aerial

CHASSIS

- FST-PAR** Front suspension - Parabolic front springs with shock absorbers and anti-roll bar
- FST-PAR3** Front suspension - Parabolic front springs with shock absorbers and anti-roll bar
- FAL5.0** Front axle design capacity - 5.0 tonne
- FAL5.6** Front Axle Design Capacity - 5.6 tonne
- FAL5.8** Front axle design capacity - 5.8 tonne
- RAL10.6** Rear axle design capacity - 10.6 tonne
- RAL9.5** Rear axle design capacity - 9.5 tonne
- RSTAB1** Rear anti-roll bar - Normal stiffness
- EBS-MED** Brake package - EBS medium including traction control & hill hold
- EBS-STD** Brake package - EBS standard package without traction control - Without
- RST-PAR1** Rear suspension - Parabolic springs
- RST-PAR3** Rear suspension - Stiffer parabolic rear springs
- FST6060** Chassis frame thickness - 6 mm web and flange
- FST7070** Chassis frame thickness - 7 mm web and flange
- FST8080** Chassis frame thickness - 8 mm web and flange
- 2BATT170** Battery Capacity - 2 x 170 Ah on the left-hand side

- ADR2** ADR Adaptation - For transportation of dangerous goods on the road - Note does NOT include safe loading pass package if required this is quoted separately
- R215P** Right fuel tank - 215-litre plastic
Min volume 80l
Max volume 430l
- UL-FUEL** Left fuel tank - Without
Min volume 80l
Max volume 215l
- ADTP-L** Adblue tank position - Chassis mounted on the left-hand side
- ADTP-R** Adblue tank position - Chassis mounted on the right-hand side
- WHC-FIX1** Wheel chock - One fixed design
- WHC-FIX2** Wheel chocks - Two fixed design
- TOWMBRH** Tow member - High mounted in centre of frame - Check the GCW in the "Truck Use" section of this specification
- C-RO40AG** Drawbar coupling - Rockinger 400 G145
- TOWF-NO1** Front towing device - One pin in bumper
- TOWF-NO2** Front towing device - Two pins in bumper
- TOWR-ONE** Light trailer coupling - Pintle type hitch attached to rear cross member for an unbraked trailer
- TREL15** Trailer electrical connection - Single 15 pin - ADR certified
- TBC-EC** Trailer brakes with EC palm coupling connectors
- RUP-FIX2** Rear underrun protection - Fixed EC approved
- RFEND-T** Rear mud wings - Temporary on drive axle for transport delivery only

WHEELS & TYRES

- RT-AL** Wheels - Howmet Alcoa brushed aluminium rims - standard holes for long stud fixing
- RT-ALDP** Wheels - Howmet Alcoa Dura-Bright aluminium rims - standard holes for long stud fixing
- RT-STEEL** Wheels - Steel rims
- SPWT-F** Spare wheel & tyre - Spare with front tyre pattern
- SWCP-LF** Spare wheel carrier on left side of chassis ahead of rear axle
- SWCP-R** Spare wheel carrier rear mounted below frame.
- SWCP-T** Spare wheel supplied temporarily strapped to chassis
- SWCP-TP** Spare wheel carrier transport mounted on frame (spare wheel carrier not included)
- JACK-10T** 10 tonne bottle jack
- JACK-8T** 8 tonne bottle jack
- GAUGE-TP** Tyre pressure gauge

DRIVELINE EQUIPMENT

- CS39A-O** Clutch - Single plate 395mm (16")
- RET-TPT** Retarder for automatic gearbox
- TC-HWO** Transmission oil cooler - water to oil
- 1COMP500** Air compressor - Single cylinder 360 cc - 500 litres per minute
- AIRIN-FR** Air intake - Under the front grille - Left-hand drive only
- AIRIN-HI** Air intake - Mounted behind cab on the left-hand side
- AIRIN-RL** Air intake - Chassis mounted behind cab on the left-hand side
- ACL1ST** Air filter - Single element
- ACL1ST-S** Air filter - two-stage element
- 24AL110B** Alternator capacity - 110 amp
- 24AL130B** Alternator capacity - 130 amp
- CCV-C** Closed crankcase ventilation
- CCV-OX** Open crankcase ventilation with oil separator and a maintenance free gas centrifuge
- EST-AID** Engine starting aid -Preheating element in the air inlet manifold
- PTER-100** Engine power-take-off - Rear-mounted with DIN100/ISO7646 flange

Standard Equipment Optional Equipment

For more detailed information about cab and powertrain equipment, please refer to separate specification sheets.

For all possible options and combinations of options please consult your Volvo sales contact who can create a specification to match your requirements using the Volvo Sales Support system (VSS).

The factory reserves the right to modify design and change equipment without previous notification. The specification can vary from country to country.

MODEL RANGE

FL514 4x2 Rigid 14 tonne - Steel Suspension FL 42 R 514L

- | | |
|--|---|
| <ul style="list-style-type: none"> □ PTER-DIN Engine power-take-off - Rear-mounted with DIN5462 (female) splined shaft for a close-coupled pump □ PTER1400 Engine power-take-off - Rear-mounted with SAE 1410 flange □ PR-HF4S Live-drive PTO for Allison gearbox output 400Nm for flange connection mounted on the side of the torque convertor □ PR-HF4SH Live-drive high speed PTO for Allison gearbox output 400Nm for hydraulic pump connection mounted on the side of the torque convertor □ PR-HF6S Live-drive PTO for Allison gearbox output 600Nm for flange connection mounted on the side of the torque convertor □ PR-HP4S Live-drive PTO for Allison gearbox output 400Nm for hydraulic pump connection mounted on the side of the torque convertor □ PR-HP4SH Live-drive high speed PTO for Allison gearbox output 400Nm for hydraulic pump connection mounted on the side of the torque convertor □ PR-HP6S Live-drive PTO for Allison gearbox output 600Nm for hydraulic pump connection mounted on the side of the torque convertor □ PTR-FH1 Rear PTO Gearbox S81 flange DIN connection □ PTR-FH2 Rear PTO Gearbox S84 flange DIN connection □ PTR-FH5 Rear PTO Gearbox S88 flange DIN connection □ PTR-PH1 Rear PTO Gearbox S81 pump DIN connection □ PTR-PH2 Rear PTO Gearbox S84 pump DIN connection □ PTR-PH4 Rear PTO Gearbox S88 pump DIN connection □ PTR-PK Electrical and solenoid prep kit for gearbox PTO □ PTR-ZF2 Rear Power Take Off flange DIN connection □ PTR-ZF3 Rear Power Take Off Gearbox pump DIN connection □ PTR-ZF4 Rear PTO Gearbox 320Nm flange connection □ PTR-ZF5 Rear PTO Gearbox 320Nm pump connection □ PTR-ZF6 Rear PTO Gearbox 320Nm flange connection □ HPG-F101 Gearbox mounted hydraulic pump - Parker F1-101 hydraulic pump gearbox mounted □ HPG-F41 Gearbox mounted hydraulic pump - Parker F1-41 gearbox mounted, fixed displacement, single flow □ HPG-F51 Gearbox mounted hydraulic pump - Parker F1-51 gearbox mounted, fixed displacement, single flow □ HPG-F61 Gearbox mounted hydraulic pump - Parker F1-61 gearbox mounted, fixed displacement, single flow □ HPG-F81 Gearbox mounted hydraulic pump - Parker F1-81 gearbox mounted, fixed displacement, single flow ■ ETC Electronic throttle control - dash mounted switch for PTO speed control | <ul style="list-style-type: none"> □ TGW-4G Telematics gateway - GSM/GPRS/4G modem, WLAN ■ WVTA Whole Vehicle Type Approved - First stage chassis cab |
|--|---|

CAB INTERIOR

- **STWPOS-L** Steering wheel position - LEFT-HAND DRIVE
- **STWPOS-R** Steering wheel position - RIGHT-HAND DRIVE
- **TAS-DIG4** Smart tachograph - Continental VDO 4.1 version 2 - legal demand from 21/08/2023
- **TSRS** Intelligent speed assist & road sign recognition

CAB EXTERIOR

- **SUNV-B** Exterior sun visor - Smoked grey
- **SUNV-PK** Exterior sun visor preparation kit only
- **AD-SIDES** Cab side deflector - Short extension panels
- **BEACON-P** Roof beacons - switch and wiring preparation only
- **BEACONA2** Roof-mounted beacons - Two LED amber beacons mounted direct on roof

SUPERSTRUCTURE PREPARATIONS

- **FBA-BTF** Lower front body attachments - For torsionally flexible - platform body
- **FBA-BTSF** Lower front body attachments - For torsionally semi-flexible body - box or curtainsider
- **RBA-T2** Rear body attachments - Divided
- **TAILPREP** Taillift preparation kit - cab switch and warning in driver display

DELIVERY SERVICES

Volvo Trucks. Driving Progress