

MODEL RANGE

FL 42R GVW10 5L air FL 42 R 510A

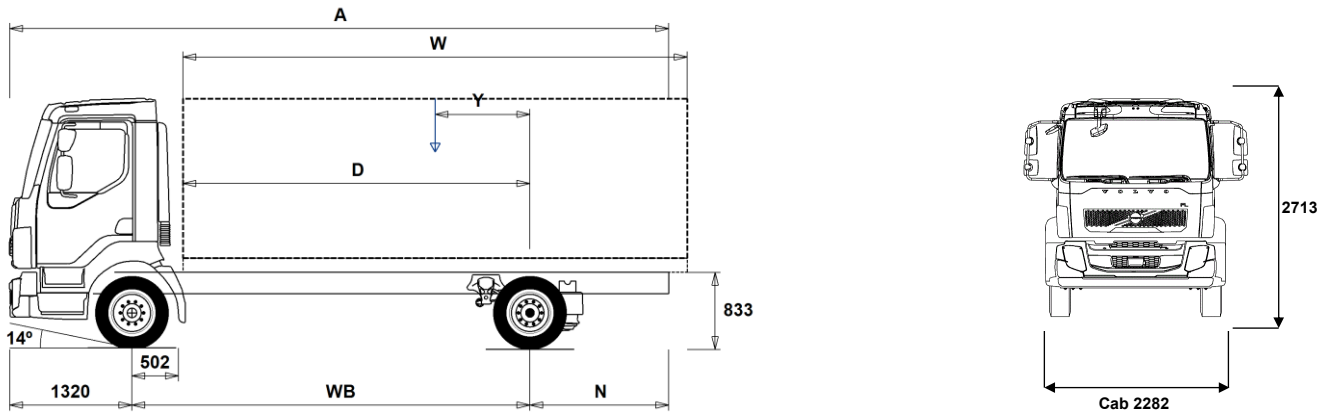

Chassis Dimensions [mm]

WB Wheelbase	3500	3800	4100	4400	4700	5000	5300	5600	5900	6200	6500
A Overall Chassis Length	6975	7425	7955	8425	8915	9435	9915	10425	10835	11430	11730
D Center of rear axle to front of body	2948	3248	3548	3848	4148	4448	4748	5048	5348	5648	5948
N Rear Overhang (Min.)	2055	1885	2445	2635	2835	2895	2895	3415	3295	3505	3755
N Rear Overhang (Max.)	2155	2305	2535	2705	2895	3115	3295	3505	3615	3910	3910
Y Center of Gravity for Payload (Min.)	-314	-346	-378	-413	-449	-494	-531	-568	-591	-647	-691
Y Center of Gravity for Payload (Max.)	640	693	747	799	853	902	954	1007	1067	1113	1158
W Body Length (Min.)	4616	5110	5602	6098	6591	7091	7587	8081	8561	9069	9579
W Body Length (Max.)	5048	5528	6008	6488	6968	7448	7928	8408	8888	9368	9848

Chassis Weights [kg]

Front Axle	2925	2935	2940	2945	2950	2965	2970	2975	2970	2990	3000
Rear Axle	1205	1215	1235	1245	1270	1305	1320	1335	1335	1375	1380
Kerb Weight	4130	4150	4175	4190	4220	4270	4290	4310	4305	4365	4380
Payload (including body, driver, fuel, etc.)	5870	5850	5825	5810	5780	5730	5710	5690	5695	5635	5620

Turning Diameter [mm]

Turning Circle Diameter Kerb to Kerb	12300	13200	14100	15000	15900	16800	17700	18600	19500	20400	21300
Turning Circle Diameter Wall to Wall	13700	14600	15500	16400	17300	18200	19100	20000	20900	21800	22700

Plated Weights [kg]

	Design
Gross Vehicle Weight	10000
Gross Combination Weight	15500
Front Axle	4000
Rear Axle	7600

Important Notes

Chassis Dimensions

Cab Height: +17 mm for CAB-CRW.
 Front Axle to Back of Cab: +1294 mm for CAB-CRW, +316 mm for CAB-SSLP.
 D-measure includes a front clearance of 50 mm and for rigid trucks also a subframe of 120 mm.
 Height can vary ± 20 mm for leaf and ± 10 mm for air suspension.
 All dimensions are for unladen chassis and any tag axles down.

Weight and dimensions are based upon the following tyres:
 Front Axle Tyres: 235/75R17.5
 Drive Axle Tyres: 235/75R17.5

Chassis weight includes oil, water, AdBlue, 0 litres fuel and without driver. Kerb weight can vary ± 3%.

Turning diameters are theoretically calculated.

Legal weights can differ from country to country.

For more detailed weight information, including optional equipment weights, ask your Volvo sales contact to enter your specification into the Volvo Weight Information system (WIS).

Do NOT use this drawing for bodybuilding. Refer to Volvo Bodybuilder Instructions and chassis assembly drawing FL42R510A.

MODEL RANGE

FL 42R GVW10 5L air FL 42 R 510A

Core components

- **CHH-LOW** Chassis height low - approx. 850 mm above ground level
- **RAD-A2V** Rear air suspension - one axle, driving
- **FL-CREW2** FL Crew cab
- **FL-DAY2** FL Day cab
- **FL-SSLP2** FL Comfort cab
- **EU6SCR** Euro 6 with SCR, particulate filter and EGR, Turbo-S
- **D5K210** Diesel engine, Euro 6, 5.1 litres, 210 hp/154 kW, 800 Nm
- **D5K240** Diesel engine, Euro 6, 5.1 litres, 240 hp/177 kW, 900 Nm
- **ATO1056**
- **ATO8006**
- **STO8006** Manual 6-speed gearbox, 850 Nm
- **ZTO1006** Manual 6-speed gearbox, 1050 Nm
- **EBR-EPG** Engine brake with exhaust pressure governor
- **RSS0819A** Rear single reduction solo axle - axle load 8 tonnes, GCW 18.75 tonnes

Packages

- **AUDIODAB** Audio system with DAB radio and DAB amplifier
- **AUDIOPD** Preparation kit for DAB radio, including DAB amplifier

Chassis

- **FST-PAR** Two-leaf front parabolic springs (normal stiffness)
- **EBS-MED** EBS (Electronic Braking System), Medium package
- **RST-AIR** Rear air springs
- **SUSPL-E1** Remote control with wander lead for air suspension levelling, 1 sensor on rear axle
- **SUSPL-E3** Three dashboard switches for air suspension levelling, 1 sensor on rear axle
- **FST6060** Frame thickness - web 6.0 mm / flange 6.0 mm
- **FST7070** Frame thickness - web 7.0 mm / flange 7.0 mm
- **FST8080** Frame thickness - web 8.0 mm / flange 8.0 mm
- **2BATT170** Batteries, 2x170 Ah
- **ADR2** ADR adaptation, 1 switch in dashboard, 1 outside on back of cab
- **R80P** Right 80-litre plastic fuel tank
Min volume 80l
Max volume 430l
- **UL-FUEL** Without left side fuel tank
- **ADTP-R** AdBlue tank on right hand side
- **WHC-FIX1** One non-collapsible wheel chock
- **WHC-FIX2** Two non-collapsible wheel chocks
- **TOWMBRH** Towing member, high-mounted in centre of frame
- **C-RO40AG** Towing coupling Rockinger 400 G-145
- **TOWF-NO1** One front towing device
- **TOWF-NO2** Two front towing devices
- **TOWR-ONE** Rear towing device in frame-end cross member
- **TREL15** 15-pin trailer connection (ADR certified)
- **TBC-EC** Trailer brake connection, European Community
- **RUP-FIX2**
- **RFEND-T** Transport mudguard

Rims and tyres

- **RT-ALDP** Dura-Bright® polished aluminium rims with standard holes (long stud fixing) on all axles
- **RT-STEEL** Steel rims on all axles
- **SPWT-F** Spare front wheel
- **SWCP-LF** Spare wheel carrier on left side in front of rear axle
- **SWCP-R** Spare wheel carrier mounted behind rear axle

■ Standard Equipment

□ Optional Equipment

For more detailed information about cab and powertrain equipment, please refer to separate specification sheets.

For all possible options and combinations of options please consult your Volvo sales contact who can create a specification to match your requirements using the Volvo Sales Support system (VSS).

The factory reserves the right to modify design and change equipment without previous notification. The specification can vary from country to country.

- **SWCP-TP** Spare wheel and carrier transport-mounted on top of frame
- **JACK-6T** Hydraulic jack, 6 tonnes. Low manual pumping force facilitates use in uncomfortable positions. Has a release valve, which permits safe, easy and precise control over rate of lowering and a filter in the oil reservoir gives protection from contamination. Colour RAL 9004. Height 171-453 mm, weight 6.1 kg

- **GAUGE-TP** Tyre pressure gauge

Powertrain equipment

- **CS39A-O** Single-plate clutch, plate diameter 395 mm
- **TC-HWO** Oil cooler for hydraulic transmissions – water/oil
- **1COMP500** Single-cylinder air compressor 360 cc, 500 l/min
- **AIRIN-FR** Front air inlet
- **AIRIN-HI** High air inlet
- **AIRIN-RL** Low air inlet, chassis mounted behind cab on left-hand side
- **ACL1ST** Air cleaner with one filter element
- **ACL1ST-S** Air cleaner with extra filter element
- **24AL110B** Alternator 110 Ampere
- **24AL130B** Alternator 130 Ampere
- **CCV-C** Closed crankcase ventilation
- **CCV-OX** Open extended crankcase ventilation with oil separator and maintenance-free gas centrifuge
- **EST-AID** Engine intake air heater
- **PTER-100** Rear engine, clutch-independent PTO, flange connection, DIN 100/ISO 7646
- **PTER-DIN** Rear engine, clutch-ind. PTO, splined shaft groove (fem), close-coupled pump DIN 5462/ISO7653
- **PTER1400** Rear engine, clutch-independent PTO, flange connection, SAE 1410/ISO 7647
- **PR-HF4S** Rear gearbox (side) PTO, flange connection
- **PR-HF4SH** Rear gearbox (side) PTO, flange connection, high-speed
- **PR-HF6S** Rear gearbox (side) PTO, flange connection
- **PR-HP4S** Preparation kit for rear, side-mounted gearbox PTO, pump connection, 400 Nm
- **PR-HP4SH** Rear gearbox PTO, pump connection, side-mounted, high-speed
- **PR-HP6S** Preparation kit for rear, side-mounted gearbox PTO, pump connection, 600 Nm
- **PTR-FH5** Rear gearbox PTO with flange connection DIN 90/ISO 7646 for propshaft, 450 Nm
- **PTR-PH4** Rear gearbox PTO Hydrocar S88, connection DIN 5462/ISO 7653 for pump, 450 Nm
- **HPG-F101** Gearbox-mounted hydraulic pump F1-101, fixed displacement, single flow
- **HPG-F41** Gearbox-mounted hydraulic pump F1-41, fixed displacement, single flow
- **HPG-F51** Gearbox-mounted hydraulic pump F1-51, fixed displacement, single flow
- **HPG-F61** Gearbox-mounted hydraulic pump F1-61, fixed displacement, single flow
- **HPG-F81** Gearbox-mounted hydraulic pump F1-81, fixed displacement, single flow

- **ETC** PTO speed control 900-1500 rpm with dash-mounted switch

Cab interior

- **TAS-DIG4** Gen 4 one-day digital tachograph, EC approved (GNSS & DSRC, EU 2020/1054)
- **TSRS2** Road sign recognition (not ISA compliant)

Cab exterior

- **SUNV-B** Exterior front sun visor, transparent dark-grey
- **AD-SIDES** Cab side air deflectors, short
- **BEACON-P** Preparation kit for roof beacons
- **BEACON-A2** Two amber LED beacons on cab front roof

MODEL RANGE

FL 42R GVW10 5L air FL 42 R 510A

Superstructure preparations

- **FBA-BTF** Front body attachment brackets, lower, for flexible body
- **FBA-BTSF** Front body attachment brackets, lower, for semi-flexible body
- **RBA-T2** Rear body attachment brackets, lower
- **TAILPREP** Tail lift preparation kit

Services

- **TGW-4G**