

MODEL RANGE

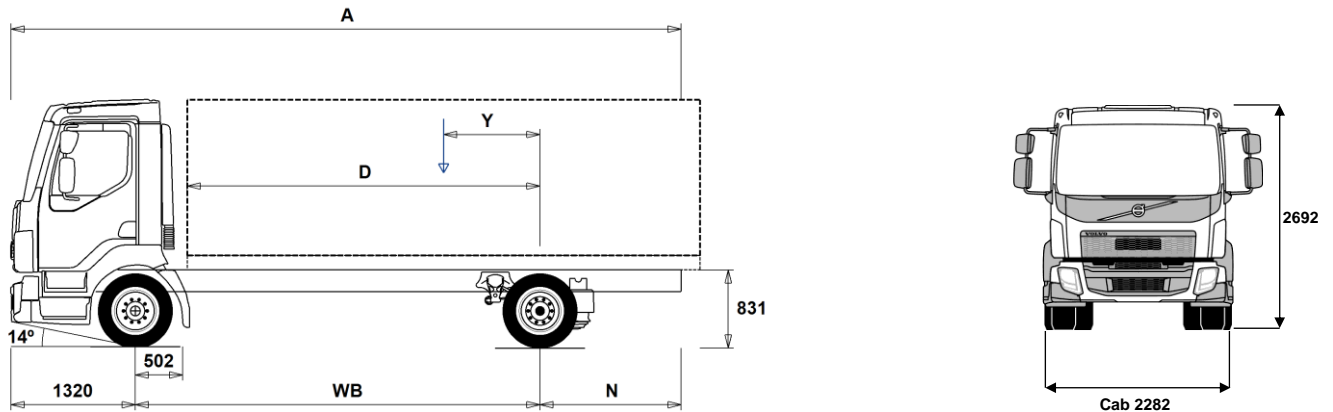

Volvo Trucks. Driving Progress

FL510 4x2 Platform 10 tonne - Rear Air Suspension FL 42 R 510A



Chassis Dimensions [mm]

WB Wheelbase	3500	3800	4100	4400	4700	5000	5300	5600	5900	6200	6500
A Overall Chassis Length	6975	7425	7955	8425	8915	9435	9915	10425	10835	11430	11730
D Center of rear axle to front of body	2948	3248	3548	3848	4148	4448	4748	5048	5348	5648	5948
N Rear Overhang (Min.)	2055	1885	2445	2635	2835	2895	2895	3415	3295	3505	3755
N Rear Overhang (Max.)	2155	2305	2535	2705	2895	3115	3295	3505	3615	3910	3910
Y Center of Gravity for Payload (Min.)	-281	-307	-332	-360	-388	-426	-455	-485	-501	-548	-584
Y Center of Gravity for Payload (Max.)	652	709	768	824	882	936	993	1050	1114	1165	1216

Chassis Weights [kg]

Front Axle	2880	2885	2885	2885	2890	2900	2905	2905	2895	2910	2920
Rear Axle	1115	1130	1150	1165	1190	1225	1240	1255	1260	1295	1300
Kerb Weight	3995	4015	4035	4050	4080	4125	4145	4160	4155	4205	4220
Payload (including body, driver, fuel, etc.)	6005	5985	5965	5950	5920	5875	5855	5840	5845	5795	5780

Turning Diameter [mm]

Turning Circle Diameter Kerb to Kerb	12300	13200	14100	15000	15900	16800	17700	18600	19500	20400	21300
Turning Circle Diameter Wall to Wall	13700	14600	15500	16400	17300	18200	19100	20000	20900	21800	22700

Plated Weights [kg]

	Plated	Design
Gross Vehicle Weight	10000	10000
Gross Combination Weight	15500	15500
Front Axle	4000	4000
Rear Axle	7600	7600

Important Notes

Chassis Dimensions

Cab Height: +39 mm for CAB-CRW.
 Front Axle to Back of Cab: +1338 mm for CAB-CRW, +330 mm for CAB-SSLP.
 D-measure includes a front clearance of 50 mm and for rigid trucks also a subframe of 120 mm.
 Height can vary ± 20 mm for leaf and ± 10 mm for air suspension.
 All dimensions are for unladen chassis and any tag axles down.

Weight and dimensions are based upon the following tyres:
 Front Axle Tyres: 235/75R17.5
 Drive Axle Tyres: 235/75R17.5

Chassis weight includes oil, water, AdBlue, 0 litres fuel and without driver. Kerb weight can vary $\pm 3\%$.

Turning diameters are theoretically calculated.

Legal weights can differ from country to country.

For more detailed weight information, including optional equipment weights, ask your Volvo sales contact to enter your specification into the Volvo Weight Information system (WIS).

Do NOT use this drawing for bodybuilding. Refer to Volvo Bodybuilder Instructions and chassis assembly drawing FL42R510A.

MODEL RANGE

FL510 4x2 Platform 10 tonne - Rear Air Suspension FL 42 R 510A

CORE COMPONENTS

- **CHH-LOW** Chassis Height - Low - for loading heights check the unique BEP chassis drawing
- **RAD-A2V** Two bag rear air suspension
- **CAB-CRW** Cab - Four-door - Six seater crewcab
Designed and built to Swedish impact and ECE R29 regulations
- **CAB-DAY** Cab - Day - with steel safety cage design.
Designed and built to Swedish impact and ECE R29 regulations
- **CAB-SSLP** Cab - Comfort with additional storage space or optional fold up bunk behind the driver - with steel safety cage design.
Designed and built to Swedish impact and ECE R29 regulations.
- **EU6SCR** Emission level - Euro VI step D
- **D5K210** Engine - D5K210 four-cylinder 5.1 litre developing 210hp at 2200rpm.
Peak torque 800Nm at 1100-1700rpm.
- **D5K240** Engine - D5K240 four-cylinder 5.1 litre developing 240hp at 2200rpm.
Peak torque 900Nm at 1100-1600rpm.
- **ATO1056** Gearbox - Automated 6-speed I-sync overdrive
- **ATO8006** Gearbox - Automated 6-speed I-sync overdrive
- **STO8006** Gearbox - Manual 6-speed overdrive
- **ZTO1006** Gearbox - Manual 6-speed overdrive
- **EBR-EPG** Engine Brake Type - Exhaust - producing 120kW at 2800rpm
- **RSS0819A** Drive Axle - RSS0819A single reduction with differential lock - design GCW 18.75 tonne

Packages

- **DRIVEFL** Cab Package - Drive
- **VISIFL** Visibility Package -
- **AIRFLOW** Airflow Package -
- **AUDIODAB** Audio System - Digital DAB AM/FM Radio with Bluetooth - without CD player
- **AUDIOPD** Audio - Preparation for DAB radio including amplifier and aerial

CHASSIS

- **FST-PAR** Front suspension type - Parabolic front springs with shock absorbers and anti-roll bar
- **EBS-MED** Brake package - EBS medium including traction control & hill hold
- **EBS-STD** Brake package - EBS standard package without traction control
- **RST-AIR** Rear suspension type - Air
- **SUSPL-E1** Air suspension levelling control - Remote control on wander-lead
- **SUSPL-E3** Air suspension levelling control - Integral dash switches
- **FST6060** Chassis frame thickness - 6 mm web and flange
- **FST7070** Chassis frame thickness - 7 mm web and flange
- **FST8080** Chassis frame thickness - 8 mm web and flange
- **2BATT170** Battery Capacity - 2 x 170 Ah on the left-hand side
- **ADR2** ADR Adaptation - For transportation of dangerous goods on the road - Note does NOT include safe loading pass package if required this is quoted separately
- **R215P** Right fuel tank - 215-litre plastic
Min volume 80l
Max volume 430l
- **UL-FUEL** Without left fuel tank
- **ADTP-R** Adblue tank position - Chassis mounted on the right-hand side
- **WHC-FIX1** Wheel chock - One fixed design
- **WHC-FIX2** Wheel chocks - Two fixed design

- **TOWMBRH** Tow member - High mounted in centre of frame - Check the GCW in the "Truck Use" section of this specification
- **C-RO40AG** Drawbar coupling - Rockinger 400 G145
- **TOWF-NO1** Front towing device - One pin in bumper
- **TOWF-NO2** Front towing device - Two pins in bumper
- **TOWR-ONE** Light trailer coupling - Pintle type hitch attached to rear cross member for an unbraked trailer
- **TREL15** Trailer electrical connection - Single 15 pin - ADR certified
- **TBC-EC** Trailer brakes with EC palm coupling connectors
- **RUP-FIX2** Rear underrun protection - Fixed EC approved
- **RFEND-T** Rear mud wings - Temporary on drive axle for transport delivery only

WHEELS & TYRES

- **RT-ALDP** Wheels - Alcoa Dura-Bright aluminium rims - standard holes for long stud fixing
- **RT-STEEL** Wheels - Steel rims
- **SPWT-F** Spare wheel & tyre - Spare with front tyre pattern
- **SWCP-LF** Spare wheel carrier on left side of chassis ahead of rear axle
- **SWCP-R** Spare wheel carrier rear mounted below frame.
- **SWCP-T** Spare wheel supplied temporarily strapped to chassis
- **SWCP-TP** Spare wheel carrier transport mounted on frame (spare wheel carrier not included)
- **JACK-6T**
- **GAUGE-TP** Tyre pressure gauge

DRIVELINE EQUIPMENT

- **CS39A-O** Clutch - Single plate 395mm (16")
- **1COMP500** Air compressor - Single cylinder 360 cc - 500 litres per minute
- **AIRIN-FR** Air intake - Under the front grille - Left-hand drive only
- **AIRIN-HI** Air intake - Mounted behind cab on the left-hand side
- **AIRIN-RL** Air intake - Chassis mounted behind cab on the left-hand side
- **ACL1ST** Air filter - Single element
- **ACL1ST-S** Air filter - two-stage element
- **24AL110B** Alternator capacity - 110 amp
- **24AL130B** Alternator capacity - 130 amp
- **CCV-C** Closed crankcase ventilation
- **CCV-OX** Open crankcase ventilation with oil separator and a maintenance free gas centrifuge
- **EST-AID** Engine starting aid -Preheating element in the air inlet manifold
- **PTER-100** Engine power-take-off - Rear-mounted with DIN100/ISO7646 flange
- **PTER-DIN** Engine power-take-off - Rear-mounted with DIN5462 (female) splined shaft for a close-coupled pump
- **PTER1400** Engine power-take-off - Rear-mounted with SAE 1410 flange
- **PTR-FH5** Rear PTO Gearbox S88 flange DIN connection
- **PTR-PH4** Rear PTO Gearbox S88 pump DIN connection
- **HPG-F101** Gearbox mounted hydraulic pump F1-101, fixed displacement, single flow.
- **HPG-F41** Gearbox mounted hydraulic pump F1-41, fixed displacement, single flow.
- **HPG-F51** Gearbox mounted hydraulic pump F1-51, fixed displacement, single flow.
- **HPG-F61** Gearbox mounted hydraulic pump F1-61, fixed displacement, single flow.
- **HPG-F81** Gearbox mounted hydraulic pump F1-81, fixed displacement, single flow.
- **ETC** Electronic throttle control - dash mounted switch for PTO speed control

CAB INTERIOR

- **STWPOS-L** Steering wheel position - LEFT-HAND DRIVE
- **STWPOS-R** Steering wheel position - RIGHT-HAND DRIVE

■ Standard Equipment □ Optional Equipment

For more detailed information about cab and powertrain equipment, please refer to separate specification sheets.

For all possible options and combinations of options please consult your Volvo sales contact who can create a specification to match your requirements using the Volvo Sales Support system (VSS).

The factory reserves the right to modify design and change equipment without previous notification. The specification can vary from country to country.

MODEL RANGE

FL510 4x2 Platform 10 tonne - Rear Air Suspension FL 42 R 510A

CAB EXTERIOR

- SUNV-B** Exterior sun visor - Smoked grey
- SUNV-PK** Exterior sun visor preparation kit only
- AD-SIDES** Cab side air deflector, short extension panels.
- BEACON-P** Roof beacons - wiring preparation only
- BEACONA2** Two amber beacons directly mounted to cab roof

SUPERSTRUCTURE PREPARATIONS

- FBA-BTF** Lower front body attachments - For torsionally flexible - platform body
- FBA-BTSF** Lower front body attachments - For torsionally semi-flexible body - box or curtainsider
- RBA-T2** Rear body attachments - Divided
- TAILPREP** Taillift preparation kit - cab switch and warning in driver display

DELIVERY SERVICES

- TGW-4G** Telematics gateway - GSM/GPRS/4G modem, WLAN
- WVTA** EC Whole Vehicle Type Approved

VOLVO

Volvo Truck Corporation
volvotrucks.com