

MODEL RANGE

FL 42R GVW10 5L air FL 42 R 510A

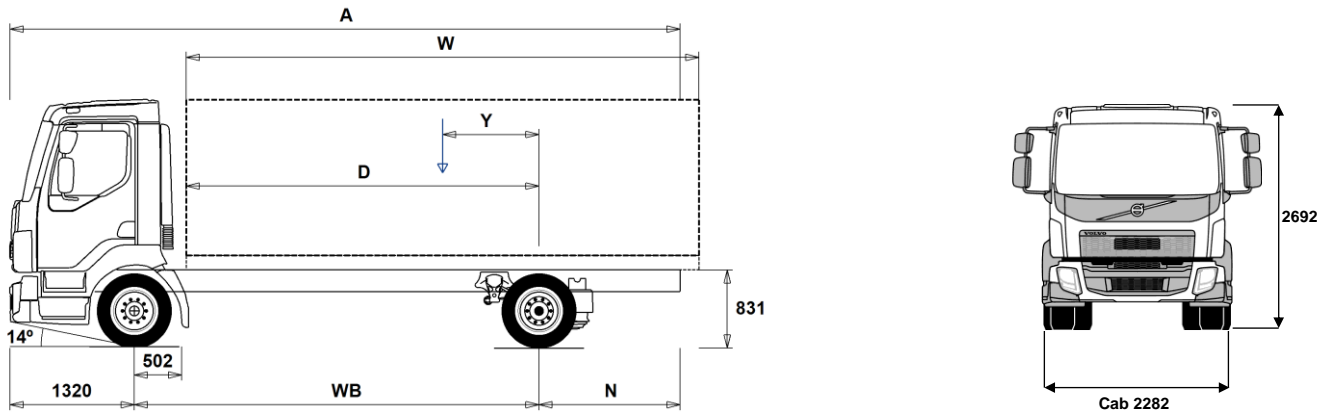

Chassis Dimensions [mm]

WB Wheelbase	3500	3800	4100	4400	4700	5000	5300	5600	5900	6200	6500
A Overall Chassis Length	6975	7425	7955	8425	8915	9435	9915	10425	10835	11430	11730
D Center of rear axle to front of body	2948	3248	3548	3848	4148	4448	4748	5048	5348	5648	5948
N Rear Overhang (Min.)	2055	1885	2445	2635	2835	2895	2895	3415	3295	3505	3755
N Rear Overhang (Max.)	2155	2305	2535	2705	2895	3115	3295	3505	3615	3910	3910
Y Center of Gravity for Payload (Min.)	-281	-307	-332	-360	-389	-426	-456	-486	-501	-549	-585
Y Center of Gravity for Payload (Max.)	657	714	773	830	888	943	1000	1057	1122	1173	1224
W Body Length (Min.)	4583	5068	5550	6036	6519	7011	7497	7982	8452	8950	9447
W Body Length (Max.)	5048	5528	6008	6488	6968	7448	7928	8408	8888	9368	9848

Chassis Weights [kg]

Front Axle	2880	2880	2880	2885	2885	2900	2900	2905	2895	2910	2915
Rear Axle	1150	1165	1185	1200	1225	1255	1270	1290	1290	1330	1335
Kerb Weight	4030	4045	4065	4085	4110	4155	4170	4195	4185	4240	4250
Payload (including body, driver, fuel, etc.)	5970	5955	5935	5915	5890	5845	5830	5805	5815	5760	5750

Turning Diameter [mm]

Turning Circle Diameter Kerb to Kerb	12300	13200	14100	15000	15900	16800	17700	18600	19500	20400	21300
Turning Circle Diameter Wall to Wall	13700	14600	15500	16400	17300	18200	19100	20000	20900	21800	22700

Plated Weights [kg]

	Design
Gross Vehicle Weight	10000
Gross Combination Weight	15500
Front Axle	4000
Rear Axle	7600

Important Notes

Chassis Dimensions

Cab Height: +39 mm for CAB-CRW.
 Front Axle to Back of Cab: +1338 mm for CAB-CRW, +330 mm for CAB-SSLP.
 D-measure includes a front clearance of 50 mm and for rigid trucks also a subframe of 120 mm.
 Height can vary ± 20 mm for leaf and ± 10 mm for air suspension.
 All dimensions are for unladen chassis and any tag axles down.

Weight and dimensions are based upon the following tyres:
 Front Axle Tyres: 235/75R17.5
 Drive Axle Tyres: 235/75R17.5

Chassis weight includes oil, water, AdBlue, 0 litres fuel and without driver. Kerb weight can vary ± 3%.

Turning diameters are theoretically calculated.

Legal weights can differ from country to country.

For more detailed weight information, including optional equipment weights, ask your Volvo sales contact to enter your specification into the Volvo Weight Information system (WIS).

Do NOT use this drawing for bodybuilding. Refer to Volvo Bodybuilder Instructions and chassis assembly drawing FL42R510A.

MODEL RANGE

FL 42R GVW10 5L air FL 42 R 510A

Core components

- **CHH-LOW** Chassis height low - approx. 850 mm above ground level
- **RAD-A2V** Rear air suspension, 1 axle - 1 driven
- **CAB-CRW** Crew cab
- **CAB-DAY** Day cab
- **CAB-SSLP** Comfort cab
- **EU6SCR** Euro 6 emission level with Selective Catalytic Reduction (SCR), particle filter and Exhaust Gas Recirculation (EGR)
- **D5K210** Four cylinder diesel engine, 5.1 litre Euro 6 SCR + EGR (Diesel Particulate Filter), 210 hp, 800 Nm
- **D5K240** Four cylinder diesel engine, 5.1 litre Euro 6 SCR + EGR (Diesel Particulate Filter), 240 hp, 900 Nm
- **ATO1056** I-Sync, Automated manual 6 speed gearbox, 1070 Nm
- **ATO8006** I-Sync, Automated manual 6 speed gearbox, 850 Nm
- **STO8006** Manual overdrive 6 speed gearbox, 850 Nm
- **ZTO1006** Overdrive 6 speed manual ZF gearbox, 1050 Nm
- **EBR-EPG** Engine brake with Exhaust Press Governor, EPG
- **RSS0819A** Rear single reduction solo axle - axle load 8 tonnes, GCW 18.75 tonnes

Packages

- **DRIVEFL** Driver convenience package FL
- **VISIFL** Visibility package FL - Optimizing the drivers field of vision around the cab
- **AIRFLOW** Airflow package FL - Includes adjustable roof spoiler, side deflector and sun visor
- **AUDIODAB** Audio System DAB
- **AUDIOPD** Audio Preparation DAB kit, incl. DAB-amplifier

Chassis

- **FST-PAR** Front parabolic leaf suspension (normal stiffness)
- **EBS-MED** EBS (Electronic Brake System) medium package incl. traction control system (TCS) and hill start aid
- **EBS-STD** EBS (Electronic Brake System) standard package (without traction control)
- **RST-AIR** Rear air suspension
- **SUSPL-E1** Remote control on wander-lead for air suspension levelling with 1 sensor on rear axle
- **SUSPL-E3** Integral three dash switches for air suspension levelling control with 1 sensor
- **FST6060** Frame section thickness - web 6.0 mm / flange 6.0 mm
- **FST7070** Frame section thickness - web 7.0 mm / flange 7.0 mm
- **FST8080** Frame section thickness - web 8.0 mm / flange 8.0 mm
- **2BATT170** Batteries 2x170 Ah
- **ADR2** ADR adaptation, transportation of dangerous goods, 2 switches
- **R80P** Right 80 litre plastic diesel tank
Min volume 80l
Max volume 430l
- **UL-FUEL** Without left diesel tank
- **ADTP-R** AdBlue tank mounted on right hand side
- **WHC-FIX1** One fixed wheel chock
- **WHC-FIX2** Two fixed wheel chocks
- **TOWMBRH** High mounted towing member, in centre of frame
- **C-RO40AG** Towing coupling Rockinger 400 G-145
- **TOWF-NO1** One front towing device
- **TOWF-NO2** Two front towing devices
- **TOWR-ONE** One rear towing device in frame end cross member
- **TREL15** 15 pol electrical trailer connector (ADR certified)
- **TBC-EC** Trailer brake connection, European Community

- **RUP-FIX2** Fixed rear underrun protection, EC approved
- **RFEND-T** Transport mounted one-piece rear fenders, only for Jockey transport
- **2024GSR** General safety regulations 2024

Rims and tyres

- **RT-ALDP** Dura-Bright aluminium rims on all axles
- **RT-STEEL** Steel rims on all axles
- **SPWT-F** Spare wheel with tyre equal to front wheel
- **SWCP-LF** Spare wheel carrier on left side in front of rear axle
- **SWCP-R** Spare wheel carrier mounted behind rear axle and below frame
- **SWCP-T** Temporary spare wheel carrier.
Spare wheel is transport mounted (strapped on top of the frame rails) with plastic strips.
- **SWCP-TP** Spare wheel carrier transport mounted with the spare wheel on top of the frame rails
- **JACK-6T** The hydraulic jack has a capacity of 6 tonnes and its low manual pumping force facilitates use in uncomfortable positions. It has a release valve, which permits safe, easy and precise control over rate of lowering. The jack has a minimum height of 170 mm and a maximum height of 450 mm. Weight: 6 kg. This jack, with low minimum height, is specially designed for chassis CHH-LOW.

- **GAUGE-TP** The practical tyre pressure gauge measures the air pressure in a tyre. It is delivered and stored in a protective plastic box

Powertrain equipment

- **CS39A-O** Single plate clutch, plate diameter 395 mm
- **TC-HWO** Oil cooler for hydraulic transmissions – water/oil
- **1COMP500** Single cylinder air compressor 360 cc / 500 l/min
- **AIRIN-FR** Front air intake, chassis mounted on right hand side, ahead of front wheel
- **AIRIN-HI** High air intake, mounted behind cab on left hand side
- **AIRIN-RL** Low air intake, chassis mounted behind cab on left hand side
- **ACL1ST** Air cleaner with one filter element
- **ACL1ST-S** Air cleaner with additional filter element
- **24AL110B** Alternator 110 Ampere
- **24AL130B** Alternator 130 Ampere
- **CCV-C** Closed crankcase ventilation
- **CCV-OX** Open crankcase ventilation with oil separator and a maintenance free gas centrifuge
- **EST-AID** Engine start pre-heating element
- **PTER-100** Rear engine mounted clutch independent power-take-off with flange connection (DIN 100 / ISO 7646)
- **PTER-DIN** Rear engine mounted clutch independent PTO with splined shaft groove (female) for a close coupled pump (DIN 5462 / ISO 7653)
- **PTER1400** Rear engine mounted clutch independent power-take-off with flange connection (SAE 1410 / ISO 7647)
- **PR-HF4S** PTO transmission, Hydrocar, flange connection, side mounted, high speed
- **PR-HF4SH** PTO transmission, Hydrocar, flange connection, side mounted, high speed
- **PR-HF6S** PTO transmission, Hydrocar, flange connection, side mounted
- **PR-HP4S** PTO transmission, Hydrocar, pump connection, side mounted
- **PR-HP4SH** PTO transmission, Hydrocar, pump connection, side mounted, high speed
- **PR-HP6S** PTO transmission, Hydrocar, pump connection, side mounted
- **PTR-FH5** Rear gearbox mounted Hydrocar S88 PTO with flange connection (DIN 90 / ISO 7646) for propeller shaft (450 Nm)
- **PTR-PH4** Rear gearbox mounted Hydrocar S88 PTO with connection (DIN 5462 / ISO 7653) for pump (450 Nm)
- **HPG-F101** Hydraulic gearbox mounted pump F1-101, fixed displacement, single flow
- **HPG-F41** Hydraulic gearbox mounted pump F1-41, fixed displacement, single flow

■ Standard Equipment □ Optional Equipment

For more detailed information about cab and powertrain equipment, please refer to separate specification sheets.

For all possible options and combinations of options please consult your Volvo sales contact who can create a specification to match your requirements using the Volvo Sales Support system (VSS).

The factory reserves the right to modify design and change equipment without previous notification. The specification can vary from country to country.

MODEL RANGE

FL 42R GVW10 5L air FL 42 R 510A

- HPG-F51** Hydraulic gearbox mounted pump F1-51, fixed displacement, single flow
- HPG-F61** Hydraulic gearbox mounted pump F1-61, fixed displacement, single flow
- HPG-F81** Hydraulic gearbox mounted pump F1-81, fixed displacement, single flow
- ETC** Electronic throttle control - dash mounted switch for PTO speed control

Cab interior

- **TAS-DIG4** Gen 4 one day digital tachograph, EC approved

Cab exterior

- SUNV-B** Exterior transparent dark grey front sun visor
- **SUNV-PK** Exterior front sun visor installation preparation kit (fasteners)
- AD-SIDES** Short cab side air deflectors
- BEACON-P** Roof beacon lights wire preparation (two cable pass throughs)
- BEACONA2** 2 amber beacon, roof mounted warning lamps

Superstructure preparations

- FBA-BTF** Front body attachments for flexible body
- FBA-BTSF** Front body attachments for semi-flexible body
- RBA-T2** Rear body attachments, divided
- TAILPREP** Tail lift preparation kit

Services

- TGW-4G** Telematics gateway with 4G modem
- **WVTA** Whole Vehicle Type Approved