

MODEL RANGE

FH 13 6x4 Tractor - Rear Air Suspension - N3 or N3G FH 64T 3A

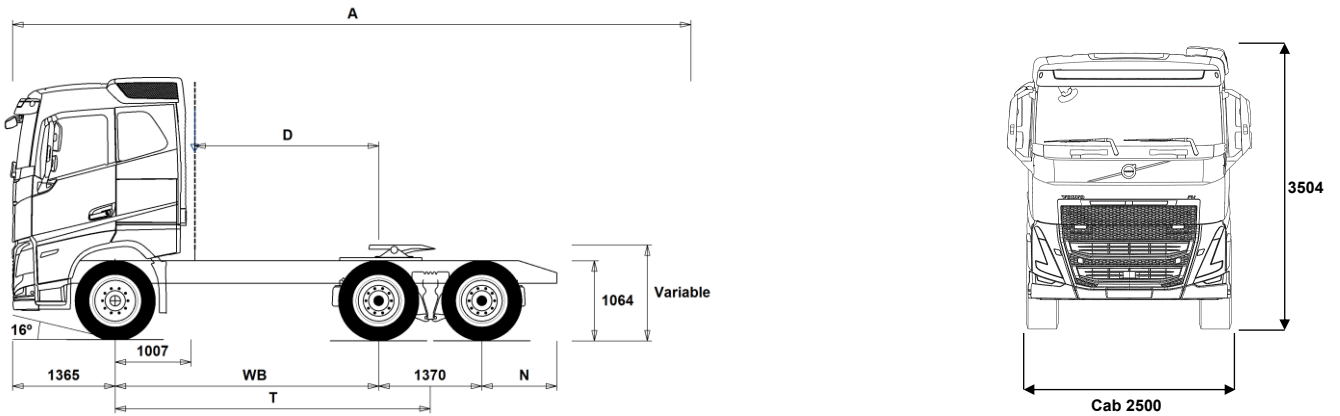

Chassis Dimensions [mm]

WB Wheelbase	3000	3200	3400	3600	3900
A Overall Chassis Length	9012	9012	9012	9012	9012
D Center of rear axle to back of cab	1943	2143	2343	2543	2843
N Rear Overhang (Min.)	805	805	805	805	805
N Rear Overhang (Max.)	995	995	995	995	995
T Theoretical Wheelbase	3685	3885	4085	4285	4585

Chassis Weights [kg]

Front Axle	5015	5035	5065	5085	5110
Rear Bogie	3765	3770	3775	3780	3785
Kerb Weight	8780	8805	8840	8865	8895

Turning Diameter [mm]

Turning Circle Diameter Kerb to Kerb	13300	13900	14500	15100	16100
Turning Circle Diameter Wall to Wall	14700	15300	15900	16500	17400

Plated Weights [kg]

	Plated	Design
Gross Vehicle Weight	26000	28500
Gross Combination Weight	44000	44000
Front Axle	7500	7500
Rear Bogie	19000	21000

Important Notes

Chassis Dimensions

Cab Height: +305 mm for CAB-HSLP, -285 mm for CAB-LSLP, +450 mm for CAB-XHES, +450 mm for CAB-XHSL.

Front Axle to Back of Cab: +74 mm for CAB-LSLP, +607 mm for CAB-XHES.

D-measure includes a front clearance of 50 mm and for rigid trucks also a subframe of 100 mm.

Height can vary ± 20 mm for leaf and ± 10 mm for air suspension.

All dimensions are for unladen chassis and any tag axles down. Chassis height used: CHH-HIGH.

Height change when chassis height CHH-MED,FRAME300: 0 mm.

Weight and dimensions are based upon the following tyres:

Front Axle Tyres: 315/80R22.5

Drive Axle Tyres: 315/80R22.5

Chassis weight includes oil, water, AdBlue, 0 litres fuel and without driver. Kerb weight can vary ± 3%.

Turning diameters are theoretically calculated.

Legal weights can differ from country to country.

For more detailed weight information, including optional equipment weights, ask your Volvo sales contact to enter your specification into the Volvo Weight Information system (WIS).

Do NOT use this drawing for bodybuilding. Refer to Volvo Bodybuilder Instructions and chassis assembly drawing FH64T3A.

MODEL RANGE

FH 13 6x4 Tractor - Rear Air Suspension - N3 or N3G FH 64T 3A

TRUCK USE

- RC-ROUGH** Road conditions - On / off-road
- RC-SMOOTH** Road Conditions - Smooth

CORE COMPONENTS

- CHH-HIGH** Chassis height - High - for loading heights check the unique BEP chassis drawing attached to this quote
- CHH-XHIG** Chassis height - X-High - for loading heights check the unique BEP chassis drawing attached to this quote
- RADD-G2** Rear air suspension, 2 axles - 2 driven, high ground clearance
- RADD-GR** RADD-GR - 6x4/8x4 Air - High
- FH-AHSLP** Cab - Aero Globetrotter sleeper, all steel safety cage design with roof mounted emergency escape hatch. Designed and built to Swedish impact and ECE R29 regulations
- FH-ALSPL** Cab - Aero low sleeper, all-steel safety cage design. Built to Swedish impact and ECE R29 regulations
- FH-ASLP** Cab - Aero sleeper, all-steel safety cage design with roof-mounted emergency escape hatch. Designed and built to Swedish impact and ECE R29 regulations
- FH-AXHES** Cab - Aero Globetrotter XXL sleeper cab for heavy haulage applications only
- FH-AXHSL** Cab - Aero Globetrotter XL sleeper, all steel safety cage design with roof mounted emergency escape hatch. Designed and built to Swedish impact and ECE R29 regulations
- FH-HSLP6** Cab - Globetrotter, all steel safety cage design with roof mounted emergency escape hatch. Designed and built to Swedish impact and ECE R29 regulations
- FH-LSLP6** Cab - Low Sleeper, all-steel safety cage design. Built to Swedish impact and ECE R29 regulations
- FH-SLP6** Cab - Sleeper, all-steel safety cage design with roof-mounted emergency escape hatch. Designed and built to Swedish impact and ECE R29 regulations
- FH-XHES6** Globetrotter XXL sleeper cab for heavy haulage applications only
- FH-XHSL6** Cab - Globetrotter XL, all steel safety cage design with roof mounted emergency escape hatch. Designed and built to Swedish impact and ECE R29 regulations
- EU6HT** Emission level - Euro VI step E
- EU6SCR** Emission level - Euro VI step E
- D13S420A** Engine - New D13K420 12.8 litre developing 420hp at 14-1800rpm. Peak torque 2100Nm at 860 -1400rpm.
- D13S460A** Engine - New D13K460 12.8 litre developing 460hp at 14-1800rpm. Peak torque 2300Nm at 900-1400rpm.
- D13S500A** Engine - New D13K500 12.8 litre developing 500hp at 14-1800rpm. Peak torque 2500Nm at 1000-1400rpm.
- D13S540A** Engine - New D13K540 12.8 litre developing 540hp at 14-1800rpm. Peak torque 2600Nm at 1000-1450rpm.
- D13T420A** Engine - New D13K420TC 12.8 litre Turbo-compound diesel developing 420hp at 14-1800rpm. Peak torque 2400Nm at 900-1250rpm.
- D13T460A** Engine - New D13K460TC 12.8 litre Turbo-compound diesel developing 460hp at 14-1800rpm. Peak torque 2600Nm at 900-1250rpm.
- D13T480A** Engine - New D13K480TC 12.8 litre Turbo-compound diesel developing 480hp at 1250-1600rpm. Peak torque 2700Nm at 900-1250rpm.
- D13T500A** Engine - New D13K500TC 12.8 litre Turbo-compound diesel developing 500hp at 14-1800rpm. Peak torque 2800Nm at 900-1250rpm.
- D13K420** D13K420 - 420hp engine
- D13K460** D13K460 - 460hp engine
- D13K500** D13K500 - 500hp engine
- D13K540** D13K540 - 540hp engine

- DIESEL** Fuel Type - Diesel
- DIESEL-B** Fuel Type - Biodiesel - engine hardware - For use with up to 100% FAME EN14214 with reduced service interval and exhaust after-treatment life
- EBR-EPG** Engine brake type - Exhaust brake controlled by steering column switch
- EBR-EPGC** Engine brake type - Exhaust pressure governor for I shift gearbox
- EBR-VEB+** Engine brake type - Volvo engine brake + and exhaust pressure governor, enhanced performance from additional exhaust rocker control. Retardation 375kW
- AT2612** Gearbox - AT2612 12-speed "I-Shift" automated mechanical suitable for gross train weights up to 60 tonne only. Refer to sales engineering when used in conjunction with a PTO
- AT2812** Gearbox - AT2812 12-speed I-Shift automated mechanical suitable for gross train weights up to 60 tonne. Refer to sales engineering when used in conjunction with a PTO
- ATO2612** Gearbox - ATO2612F 12-speed I-Shift overdrive automated mechanical, suitable for gross train weights up to 100 tonne. Refer to sales engineering when used in conjunction with a PTO
- ATO3112** Gearbox - ATO3112 12-speed I-Shift overdrive automated mechanical, suitable for gross train weights up to 60tonne. Refer to sales engineering when used in conjunction with a PTO
- SPO2812** Gearbox - SPO2812 - 12-speed I-shift Dual Clutch automated mechanical GCW 60tonne
- ASO-C** Crawler gear - Ratio direct top gearbox 19:1 Ratio Overdrive gearbox 17:1
- ASO-ULC** Ultra low crawler and crawler gear - Ratios direct top gearbox 32:1 and 19:1 Ratios Overdrive box 32:1 and 17:1
- TAAXLIFT** Rear axle lift for double drive bogie CONTACT VOLVO SALES ENGINEERING to check lift capability
- RTH2610B** Drive axles - RTH2610B 26-tonne hub reduction tandem with differential and cross locks* - design GCW 100tonne, 4 planetary gears * Cross locks replaced by a dog clutch if tandem axle lift is specified.
- RTH2610F** Drive axles - RTH2610F 26-tonne hub reduction tandem with differential and cross locks* - design GCW 100tonne * Cross locks replaced by a dog clutch if tandem axle lift is specified.
- RTS2310A** Drive axles - RTS2310A 23-tonne single reduction tandem with differential and cross locks*- design GCW 100tonne * Cross locks replaced by a dog clutch if tandem axle lift is specified
- RTS2370A** Drive axles - RTS2370A 23-tonne single reduction tandem with differential and cross locks*- design GCW 70tonne * Cross locks replaced by a dog clutch if tandem axle lift is specified

PACKAGES

- WEIGHTO** Weight optimisation package
- FP-D13** Fuel Package
- AIRFLOW** Air flow package including roof and side air deflectors plus chassis skirts
- DRIV-EXT** Cab package - Drive Extended
- DRIV-SEL** Cab Package - Drive Select
- 1LIVIN++** Sleep & Resting Package - Living one-bed ++
- 1LIVING** Sleep & Resting Package - Living one-bed
- 1LIVING+** Sleep & Resting Package - Living one-bed +
- 2LIVIN++** Sleep & Resting Package - Living two-bed ++
- 2LIVING** Sleep & Resting Package - Living two-bed
- 2LIVING+** Sleep & Resting Package - Living two-bed +
- INFOHIGH** Media Information Platform - Medium level

- Standard Equipment
- Optional Equipment

For more detailed information about cab and powertrain equipment, please refer to separate specification sheets.

For all possible options and combinations of options please consult your Volvo sales contact who can create a specification to match your requirements using the Volvo Sales Support system (VSS).

The factory reserves the right to modify design and change equipment without previous notification. The specification can vary from country to country.

MODEL RANGE

FH 13 6x4 Tractor - Rear Air Suspension - N3 or N3G FH 64T 3A

- SAFE-EXT** Safety Package - Extended
- SAFE-SEL** Safety Package - Select
- COOLCM22** Energy optimization++ package
- CHASSIS**
- FST-AIR** Front suspension type - Air
- FST-PAR** Front suspension type - 2 leaf parabolic springs
- FST-PAR3** Front suspension type - 3 leaf parabolic springs
- FST-PL1** Front suspension type - Lightweight 2 leaf parabolic springs - top leaf steel - lower composite
- FSL5-BAS** Front suspension levelling - basic stroke
- FSL5-HI** Front suspension levelling - high stroke for demount operations - check with bodybuilder
- FAL10.0** Front axle design capacity - 10 tonne - check tyre capacity
- FAL6.5** Front axle design capacity - 6.5 tonne
- FAL7.5** Front axle design capacity - 7.5 tonne
- FAL8.0** Front axle design capacity - 8.0 tonne - check tyre capacity
- FAL8.5** Front axle design capacity - 8.5 tonnes
- FAL9.0** Front axle design capacity - 9.0 tonne - check tyre capacity
- FSM-LUB** Front suspension maintenance - Lubricated rear shackles on pins and bushings
- FSTAB** Front anti-roll bar - Normal stiffness
- FSTAB2** Front anti-roll bar - Medium stiffness
- FSTAB3** Front anti-roll bar - High stiffness
- RAL19** Rear bogie design capacity - 19 tonne
- RAL21** Rear bogie design capacity - 21 tonne
- RAL23** Rear bogie design capacity - 23 tonne
- RAL26** Rear bogie design capacity - 26 tonne
- RSTAB1** Rear anti-roll bar - Normal stiffness
- RSTAB3** Rear anti-roll bar - Stiff
- RALIM105** Rear-axle load limiter - 10.5 tonne - speed controlled
- RALIM115** Rear-axle load limiter -11.5 tonne - speed controlled
- RALIM13** Rear-axle load limiter - 13 tonne
- RALIM95** Rear-axle load limiter - 9.5 tonne
- ASF-DL1** Air suspension with 1 driving level
- ASF-DL3** Air suspension with 3 driving levels
- ACTST-TO** Active Steering- Volvo Dynamic Steering - VDS - with extra electronic pump and torque overlay
- ASFE-BAS** Active steering feature - Basic - Volvo Dynamic Steering - VDS - only
- ASFE-OG** Active steering feature - Volvo Dynamic Steering - VDS - with stability assist - oversteer
- ASFE-PO** Active steering feature - Volvo Dynamic Steering - VDS - with personal settings and stability assist
- ASFE-PS** Active steering feature - Volvo Dynamic Steering - VDS - with personal settings
- PSP-FIX** Power steering pump - Fixed displacement
- PSP-VAR** Power steering pump - Variable displacement
- PSP-VAR2** Power steering pump - Variable displacement with electronic control
- EBS-MED** Brake package - EBS medium including "hill" hold function
- AUXPARK** Auxiliary parking brake - Additional spring brakes
- RST-AIR** Rear suspension type - Air
- RST-AIR6**
- FRAME300** Chassis frame section external height - 300 mm
- FST7070** Chassis frame thickness - 7 mm web and flange
- FST8080** Chassis frame thickness - 8 mm web and flange
- FIL-EEEB** Chassis frame inner liner - From the end of the engine to the end of the bogie
- FIL-TXEB** Chassis frame inner liner - From gearbox member to the end of the bogie
- BBOX-EF** Battery box position - End of the frame in rear overhang
- BBOX-L** Battery box position - Left hand side
- BATS-D** Dual energy battery system - 2 living batteries and 2 starter batteries.
- BATS-S** Single energy battery system (2 batteries)
- 2BAT210B** Battery Capacity - 2 x 210 Ah - Gel type
- 2BAT210C** Battery Capacity - 2 x 210 Ah - AGM Absorbent Glass-fibre Material type
- BATTAMP** Battery management - Voltage and current gauge
- BATTIND** Battery management - Voltage, current and charge indicators
- ADR2** ADR Adaptation - For transportation of dangerous goods on the road - Note does NOT include safe loading pass package if required this is quoted separately
- MSWI-A** Battery master switch - ADR switch circuit shut down
- MSWI-R** Battery master switch - Key fob operated remote controlled
- R330A71** Right fuel tank - 330litre aluminium diameter 710mm
Min volume 150l
Max volume 810l
- UL-FUEL** Left fuel tank - Without
Min volume 160l
Max volume 730l
- ADTP-BC** AdBlue tank position - Behind and under the cab on the right-hand side
- ADTP-L** AdBlue tank position - Chassis mounted on the left-hand side
- ADTP-R** AdBlue tank position - Chassis mounted on the right-hand side
- ADB048** Plastic AdBlue tank - 48 litre
- ADB064** Plastic AdBlue tank - 64 litre
- ADB065** Plastic AdBlue tank - 65 litre under/behind the cab
- ADB068** Plastic AdBlue tank - 68 litre
- ADB083** Plastic AdBlue tank - 83 litre
- ADB090** Plastic AdBlue tank - 90 litre
- ADB099** Plastic AdBlue tank - 99 litre under/behind the cab
- ADB112** Plastic AdBlue tank - 112 litre
- ADTC-BF** AdBlue tank cover with satin alloy look decorative cover
- FCAP-L** Diesel and AdBlue filler cap - Locking
- FUFF-AS** Fuel filler - Anti-spill device
- FUFF-ATS** Fuel filler - Anti-spill & anti-syphon device
- ESH-LEFT** Exhaust - Horizontal silencer - left outlet
- ESH-REAR** Exhaust - Horizontal silencer - rear outlet
- ESH-RIGH** Exhaust - Horizontal silencer - right outlet
- ESH-VERT** Exhaust - Horizontal silencer - vertical outlet
- EXST-SSP** Stainless steel exhaust stack - NOT polished
- EXST-ST** Steel exhaust stack
- WHC-FIX2** Wheel chocks - Two fixed design
- WHC-FOL2** Two foldable wheel chocks
- WHCP-F** Wheel chock carrier position - In the front part of the vehicle
- WHCP-M** Wheel chock carrier position - Middle part of the vehicle
- WHCP-T** Wheel chock carrier position - Outer luggage locker
- TB-L80** Toolbox 800 mm, left side
- TB-R80** Toolbox 800 mm, right side
- SUP-BAS** Side guards - Check with bodybuilder chassis space requirements
- SUP-LOW** EC approved low chassis side guards
- CHAIN-S** Snow chains
- HOOK-SC** Snow chain hooks
- TOWF-NO1** Front towing device - One detachable - stored in cab
- TOWF-NO2** Front towing device - Two detachable - stored in cab
- TOWR-ONE** Towing hitch attached to rear crossmember
- TREL15** Trailer electrical connection - Single 15 pin - ADR certified
- TREL7** 7 pole - 24N trailer electrical suzie
- TREL7-7** Trailer electrical connection - 2 x 7 pin - 24N and 24S
- TBC-DUO** Trailer brake connections - Duomatic type
- TBC-EC** Trailer brake connections - EC palm coupling connectors
- TBC-GBR** Trailer brake connections - 'C' and 'CA' type

Standard Equipment Optional Equipment

For more detailed information about cab and powertrain equipment, please refer to separate specification sheets.

For all possible options and combinations of options please consult your Volvo sales contact who can create a specification to match your requirements using the Volvo Sales Support system (VSS).

The factory reserves the right to modify design and change equipment without previous notification. The specification can vary from country to country.

MODEL RANGE

FH 13 6x4 Tractor - Rear Air Suspension - N3 or N3G FH 64T 3A

- **TRBR-STA** Stationary trailer brake control
- **TRB-STRE** Stretch Brake - Automatic low speed trailer brake activation to avoid jack-knifing and improve steerability
- **RFEND-B** Rear mud wings - Three piece EC approved and spray flaps
- **RFH-BAS** Basic rear wing height
- **RFH-HIG** High rear wing height - higher wing tops
- **RFH-LOW** Lower rear wing height - shallower wing tops
- **ATANK-AL** Air tanks - Aluminium
- **ATANK-ST** Air tanks - Steel
- **TL-LED** Rear lights - LED
- **BLIGHT-E** Emergency brake light

WHEELS & TYRES

- **RT-AL** Wheels - Howmet Alcoa brushed aluminium rims - standard holes for long stud fixing
- **RT-AL1** Wheels - Howmet Alcoa brushed aluminium rims LVL one - standard holes for long stud fixing
- **RT-AL1DU** Wheels - Howmet Alcoa brushed aluminium rims LVL one - countersunk holes for short stud fixing
- **RT-ALDP** Wheels - Howmet Alcoa Dura-Bright aluminium rims - standard holes for long stud fixing
- **RT-ALDPD** Wheels - Howmet Alcoa Dura-Bright EVO aluminium rims - countersunk holes for short stud fixing
- **RT-ALDU** Wheels - Howmet Alcoa brushed aluminium rims - countersunk holes for short stud fixing
- **RT-STEEL** Wheels - Steel rims
- **WCAP** Aerodynamic hub caps
- **SPWT-D** Spare wheel & tyre with rear tyre pattern
- **SPWT-F** Spare wheel & tyre with front tyre pattern
- **SWCP-LF** Spare wheel carrier on left side of chassis ahead of rear axle
- **SWCP-T** Spare wheel supplied temporarily strapped to chassis
- **SWCP-TP** Temporary spare wheel carrier on top of chassis frame
- **JACK-12T** 12 tonne bottle jack
- **JACK-15T** 15 tonne bottle jack
- **JACK-20T** 20 tonne bottle jack
- **TOOL-BAS** Toolkit - Basic
- **TOOLKIT** Toolkit - Complete
- **INFLAHO** Tyre inflation hose
- **GAUGE-TP** Tyre pressure gauge

DRIVELINE EQUIPMENT

- **TRAP-HD** Reinforced gearbox application
- **DRM-BE** Drive mode - Balanced & Economy
- **DRM-E** Drive mode - Economy
- **PVT-MAP** I-See Predictive Cruise Control - using map-based topography information
- **PVT-MTM** I-See Predictive Cruise Control - using map-based topography information with lower operating settings
- **CRUIS-E** Cruise control - with I-roll and I-cruise, controls in steering wheel
- **CRUIS-E5** Eco torque software - Improved economy mode. Fuel economy optimized cruise control for I-Save
- **AMSO-AUT** Enhanced I-shift software with manual shift available in auto mode and kickdown facility on accelerator pedal
- **AVO-ENH** I-Shift application software - Construction and off road applications
- **APF-ENH** I-shift enhanced PTO functions
- **RET-TH** Gearbox mounted retarder
- **TC-MAOH2** Extra high performance transmission oil cooler - air to oil with front mounted radiator
- **TC-MWO** Basic transmission oil cooler - water to oil
- **2COM1100** Air compressor - Two-cylinder 1100 litres per minute

- **2COMP870** Air compressor - Two-cylinder 870 litres per minute
- **2COMP900** Air compressor - Two-cylinder 900 litres per minute
- **CLU-AIRC** Clutchable air compressor
- **AIRIN-FR** Front air intake fitted to the underside of cab engine tunnel
- **AIRIN-HI** Air intake - Roof-mounted behind cab on the left-hand side
- **AIRIN-LO** Low level air intake behind cab on left hand side
- **ACL1ST-S** Air filter - two-stage element
- **24A150BL** Alternator capacity - 150 amp
- **24A180BL** Alternator capacity - 180 amp
- **24AL110B** Alternator capacity - 110 amp
- **24AL150B** Alternator capacity - 150 amp
- **CCV-C** Closed crankcase engine ventilation
- **CCV-OX** Closed crankcase ventilation for cold markets
- **PRIM-EL** Electrical priming pump
- **PRIM-MAN** Manual priming pump
- **FUEQ-EH** Fuel line electric heater
- **AF-R** Hot fuel recirculation heated fuel filter
- **FUEFE2LW** Large engine mounted dual fuel filter with water separator
- **EST-AID** Engine starting aid -Preheating element in the air inlet manifold
- **220EBH15** 220V/1.5Kw electric engine block heater
- **PTER-100** Engine power-take-off - Rear-mounted with DIN100/ISO7646 flange
- **PTER-DIN** Engine power-take-off - Rear-mounted with DIN5462 (female) splined shaft for a close-coupled pump
Models with 3 steering axles will use this to drive the steering pump (AUXPSP)
- **PTER1400** Engine power-take-off - Rear-mounted with SAE 1410 flange
- **HPE-F101** Parker F1-101, engine mounted, fixed displacement, single flow, engine mounted hydraulic pump
- **HPE-F41** Parker F1-41, engine mounted, fixed displacement, single flow, engine mounted hydraulic pump
- **HPE-F51** Parker F1-51, engine mounted, fixed displacement, single flow, engine mounted hydraulic pump
- **HPE-F61** Parker F1-61, engine mounted, fixed displacement, single flow, engine mounted hydraulic pump
- **HPE-F81** Parker F1-81, engine mounted, fixed displacement, single flow, engine mounted hydraulic pump
- **HPE-T53** Parker F2-53/53, engine mounted, Fixed displacement, Twin flow engine mounted hydraulic pump
- **HPE-T70** Parker F2-70/35, engine mounted, Fixed displacement, Twin flow engine mounted hydraulic pump
- **HPE-V45** Parker VP1-45, variable displacement, single flow, engine mounted hydraulic pump
- **HPE-V75** Parker VP1-75, variable displacement, single flow, engine mounted hydraulic pump
- **PTR-D** Gearbox PTO for plug-in pump, 0.71xeng speed
- **PTR-DH** Gearbox driven high speed PTO for one plug-in hydraulic pump
- **PTR-DM** Gearbox driven medium speed PTO for one plug-in hydraulic pump
- **PTR-F** Gearbox driven PTO with rear flange connection
- **PTR-FH** Gearbox driven high speed PTO with SAE drive flange
- **PTR-FL** Gearbox driven low speed PTO with SAE drive flange
- **PTRD-D** Gearbox driven HIGH SPEED PTO for two plug-in hydraulic pumps
- **PTRD-D1** PTRD-D1 Gearbox driven HIGH SPEED PTO (1 SAE flange & 1 plug-in hydraulic pump)
- **PTRD-D2** Gearbox driven HIGH SPEED PTO (2 SAE flanges & 1 plug-in hyd pump)
- **PTRD-F** PTO with 1 DIN + 1 flange connection rear, manual gearbox
- **HPG-F101** Gearbox mounted hydraulic pump - Parker F1-101 hydraulic pump gearbox mounted
- **HPG-F41** Gearbox mounted hydraulic pump - Parker F1-41 gearbox mounted, fixed displacement, single flow
- **HPG-F51** Gearbox mounted hydraulic pump - Parker F1-51 gearbox mounted, fixed displacement, single flow

■ Standard Equipment □ Optional Equipment

For more detailed information about cab and powertrain equipment, please refer to separate specification sheets.

For all possible options and combinations of options please consult your Volvo sales contact who can create a specification to match your requirements using the Volvo Sales Support system (VSS).

The factory reserves the right to modify design and change equipment without previous notification. The specification can vary from country to country.

MODEL RANGE

FH 13 6x4 Tractor - Rear Air Suspension - N3 or N3G FH 64T 3A

<input type="checkbox"/> HPG-F61	Gearbox mounted hydraulic pump - Parker F1-61 gearbox mounted, fixed displacement, single flow	<input type="checkbox"/> WARNLAMP	Portable warning lamp
<input type="checkbox"/> HPG-F81	Gearbox mounted hydraulic pump - Parker F1-81 gearbox mounted, fixed displacement, single flow	<input type="checkbox"/> LAMP-IN	Inspection lamp
<input type="checkbox"/> STWPOS-L <input checked="" type="checkbox"/> STWPOS-R	Steering wheel position - LEFT-HAND DRIVE Steering wheel position - RIGHT-HAND DRIVE	<input type="checkbox"/> BULBKIT	Bulb and fuse kit
<input type="checkbox"/> STWM-LE	Steering wheel - Leather	<input checked="" type="checkbox"/> WRITEPAD	Writing pad
<input type="checkbox"/> STGW-AD2 <input checked="" type="checkbox"/> STGW-ADJ	Steering wheel adjustment - Neck tilt, column height and angle Steering wheel adjustment - Column height and angle	<input checked="" type="checkbox"/> DST-CF4	Driver seat - Suspended, adjustable shock absorber, travel, backrest & lumbar controls with integrated seatbelt
<input checked="" type="checkbox"/> AIRBAG	Driver air bag	<input type="checkbox"/> DST-CF5	Driver seat - Suspended with adjustable shock absorber, travel, backrest, lumbar & heat controls with integrated seatbelt
<input checked="" type="checkbox"/> DRC-AMI	DPF Regeneration control switch - for manual and switching off regeneration	<input type="checkbox"/> DST-CF6	Driver seat - Suspended with adjustable shock absorber, travel, backrest, lumbar, heat and ventilation controls with integrated seatbelt
<input checked="" type="checkbox"/> 1DAYDIG4	Smart tachograph - Continental VDO 4.1 version 2 - legal demand from 21/08/2023	<input type="checkbox"/> DST-LUX1	Driver seat - Deluxe 1: electrical adjustment with memory function, lumbar support, heating & ventilation with integrated seatbelt
<input type="checkbox"/> ARSL	Additional road speed limit - switch in dashboard	<input type="checkbox"/> DST-LUX2	Driver seat - Deluxe 2: electrical adjustment with memory function, lumbar support & heating with integrated seatbelt
<input checked="" type="checkbox"/> ESP-BAS1	Electronic Stability Control ESC	<input type="checkbox"/> SBD-RED	Seat belt colour - Red
<input type="checkbox"/> ESPC-RO	Additional ESC functions - Reduced / Off	<input type="checkbox"/> SBPRE-DS	Driver seat belt pretensioner
<input type="checkbox"/> HWSS-ACB	Forward collision warning with adaptive cruise control and AEBs advanced emergency brake system	<input type="checkbox"/> PST-BAS1	Passenger seat - Fixed non suspended fold up with seatbelt mounted on cab "B" post
<input checked="" type="checkbox"/> HWSS-FCB	Forward collision warning with AEBs advanced emergency brake system	<input type="checkbox"/> PST-CF4	Passenger seat - Suspended, adjustable shock absorber, travel, backrest & lumbar controls with integrated seatbelt
<input checked="" type="checkbox"/> LSS-DW <input type="checkbox"/> LSS-DW3	Lane departure warning system Lane departure warning system with pilot assist	<input type="checkbox"/> PST-CF5	Passenger seat - Suspended with adjustable shock absorber, travel, backrest, lumbar & heat controls with integrated seatbelt
<input checked="" type="checkbox"/> LCS4 <input type="checkbox"/> LCS5	Side Collision Avoidance Support - Passenger and driver side Side Collision Avoidance Support - Active support with emergency brake on passenger side. Collision warning on passenger and driver side	<input type="checkbox"/> PST-RX1	Passenger seat - Fixed non suspended, features: 90-degree rotation and tilt function with seatbelt mounted on cab "B" post
<input checked="" type="checkbox"/> DAS-W	Driver Alert Support system	<input type="checkbox"/> PST-STD2	Passenger seat - Fixed with backrest adjustment, non suspended with seatbelt mounted on cab "B" post
<input type="checkbox"/> RSSENS-W	Rain sensing windscreen wipers	<input checked="" type="checkbox"/> PST-STD4	Passenger seat - Standard suspended with seatbelt mounted on cab "B" post
<input checked="" type="checkbox"/> CU-ECC	Cab climate Unit - Electrically controlled air conditioning with sun sensor	<input type="checkbox"/> SBPRE-PS	Passenger seat belt pretensioner
<input type="checkbox"/> CU-ECC2	Cab climate Unit - Electrically controlled air conditioning with a carbon filter, sun, mist, and air quality sensor	<input type="checkbox"/> ARMRE-BB <input type="checkbox"/> ARMRE-DB <input type="checkbox"/> ARMRE-PB	Armrests - Two on both driver & passenger seats Armrests - Two on the driver seat Armrests - Two on the passenger seat
<input checked="" type="checkbox"/> IGT-BUT	Vehicle starting - Push-button	<input type="checkbox"/> ARU-BAS <input type="checkbox"/> ARU-LEA	Armrest upholstery - Vinyl Armrest upholstery - Leather
<input checked="" type="checkbox"/> IMMOBIL	Immobiliser	<input checked="" type="checkbox"/> GRABHI-B <input type="checkbox"/> GRABHI-L	Instep cab grab handle - Steel finish Instep cab grab handle - Leather finish
<input type="checkbox"/> ALARM-E	Vehicle alarm - Cab plus external sensor for body/trailer	<input checked="" type="checkbox"/> FMAT-RUB <input type="checkbox"/> FMAT-TX2	Footwell floor mats - Rubber Footwell floor mats - Two sets, Rubber and textile with an embossed pile supplied in the cab
<input type="checkbox"/> AUD-EXT	Extended audio - Amplifier	<input checked="" type="checkbox"/> LBK80F	Lower bunk - Fixed with wide middle section 815 in the centre x 2000 mm
<input type="checkbox"/> PHONE-PK	Telephone preparation kit (antenna, antenna attachm. cable incl.)	<input type="checkbox"/> LBK80FRE	Lower bunk - Electrically operated recliner with wide middle section 815 in the centre x 2000 mm
<input type="checkbox"/> ISUNS-BS <input checked="" type="checkbox"/> ISUNS-DS	Side sun visor - Driver & passenger side Side sun visor - Driver-side	<input type="checkbox"/> LBK80FRM	Lower bunk - Manually operated recliner with wide middle section 815 in the centre x 2000 mm
<input type="checkbox"/> ISUNF-RE <input checked="" type="checkbox"/> ISUNF-RM	Electrically operated textile interior sun blind Manually operated textile interior sun blind	<input type="checkbox"/> MATL-FI <input type="checkbox"/> MATL-FI4 <input checked="" type="checkbox"/> MATL-SF	Lower mattress - Firm pocket sprung Lower mattress - Firm, memory foam, 2000x700x130 mm Lower mattress - Flexi-zone semi-firm, pocket springs up to 100kg - 16 stone
<input type="checkbox"/> CSPL-BX <input checked="" type="checkbox"/> CSPL-BXD	Lower center dash open storage box Lower centre dash drawer	<input type="checkbox"/> OLMAT-BA <input type="checkbox"/> OLMAT-PR	Mattress overlay protector - 35mm thick Mattress overlay protector - Premium 50mm thick
<input type="checkbox"/> ADFS	Two extra DIN slots in front shelf - can be fitted with card or drawer available as an accessory	<input type="checkbox"/> TBK60AD <input type="checkbox"/> TBK60F <input type="checkbox"/> TBK70AD <input type="checkbox"/> TBK70F	Top bunk - Height adjustable foldable 600 x 1900mm Top bunk - Fixed foldable 600 x 1900mm Top bunk - Height adjustable foldable 700 x 1900mm Top bunk - Fixed foldable 700 x 1900mm
<input checked="" type="checkbox"/> BUPALARM	Reverse alarm	<input type="checkbox"/> PH-CAB2 <input type="checkbox"/> PH-ENGCA	Cab parking heater -1.8kW Air to air Cab parking heater - Engine and cab
<input type="checkbox"/> RTOLL-PK	Road toll PREPARATION kit for trucks operating with "Toll Collect" in Germany	<input type="checkbox"/> CPC-ADV	I-ParkCool - Advanced cab parking cooler with 120V DC electrical compressor
<input type="checkbox"/> LOADIND	Load indicator with central dashboard display	<input checked="" type="checkbox"/> SLCP-BAS	Sleeper control panel - Basic with switches for interior light, night heater, roof hatch and door lock
<input type="checkbox"/> REMC-MF	Multi-functio wireless remote control		
<input type="checkbox"/> FIREXT3S	Fire extinguisher - 3kg mounted on the seat base		
<input type="checkbox"/> WARNVEST	High visibility warning vest - No sleeves		
<input type="checkbox"/> AIDKIT	First aid kit - Legal demand for EU markets including delivery to EU bodybuilder		
<input type="checkbox"/> AIDKIT1B	First aid kit - Legal demand for trucks transiting Germany		

Standard Equipment Optional Equipment

For more detailed information about cab and powertrain equipment, please refer to separate specification sheets.

For all possible options and combinations of options please consult your Volvo sales contact who can create a specification to match your requirements using the Volvo Sales Support system (VSS).

The factory reserves the right to modify design and change equipment without previous notification. The specification can vary from country to country.

MODEL RANGE

FH 13 6x4 Tractor - Rear Air Suspension - N3 or N3G FH 64T 3A

<ul style="list-style-type: none"> <input type="checkbox"/> SLCP-LUX Sleeper control panel - Luxury with switches for interior light, night heater, roof hatch, door lock, alarm clock, window and radio <input type="checkbox"/> SAFE Driver's Safe Box <input type="checkbox"/> RUS-BAS Rear cab upper storage - 300 mm high <input type="checkbox"/> RUS-HIG Rear cab upper storage - 440 mm high - volume 245 litres <input type="checkbox"/> TABLE Bunk table - Folding and height adjustable fitted on lower bunk <input type="checkbox"/> REFR-RUS Fridge - 28 litre rear upper wall mounted with dividers <input type="checkbox"/> REFRIG Fridge - 33 litre under-bunk mounted with freezer dividers <input type="checkbox"/> MICRO-PK Microwave equipment - Wiring preparation kit for oven <input type="checkbox"/> BOTH-D Bottle holder - One under dashboard centre section <input type="checkbox"/> BOTH-DL Bottle holders - Two. One under dashboard centre section and one mounted to the under bunk drawer <input type="checkbox"/> BOTH-L Bottle holder - One mounted to the under bunk drawer <input type="checkbox"/> COFMA-PK Coffee maker - Preparation kit. <input type="checkbox"/> SOL12S Sleeper, single, 12v outlet <input checked="" type="checkbox"/> INLI-BAS Interior light - White LEDs <input type="checkbox"/> INLI-NL Interior light - White and red nightlight LEDs without dimmer <input type="checkbox"/> INLI-NLD Interior light - White and red nightlight LEDs with dimmer <input type="checkbox"/> ARL-FLEX Flexible reading lamps - Two "snake" type <input checked="" type="checkbox"/> RH-EE Fixed tinted glass sky window with emergency exit <input type="checkbox"/> RH-ER Steel roof hatch - Electrically operated, rear opening with emergency exit <input type="checkbox"/> RH-ETR Tinted glass roof hatch - Electrically operated, rear opening with emergency exit <input type="checkbox"/> RH-MTR Tinted glass roof hatch - Manually operated, rear opening with emergency exit <input checked="" type="checkbox"/> GLAS-TIN Cab windows - Tinted <input type="checkbox"/> SWIND-BS Cab side window - On both sides behind 'B' post <input checked="" type="checkbox"/> VANMIR Vanity mirror - In front shelf <input type="checkbox"/> AS-FUS Extra shelf in front compartments <input type="checkbox"/> INFOT-PK TV mounting preparation kit - Above the driver's door, includes bracket, electrical and speaker connections 	<ul style="list-style-type: none"> <input checked="" type="checkbox"/> HCC-INEX Lockable front service hatch - Activated by door lock remote <input type="checkbox"/> MIRCFPCS Mirrors - Electrically heated and operated main and wide-angle with manually adjusted passenger kerb and front mirror and position camera in nearside mirror arm <input type="checkbox"/> MIRCMCP Camera monitoring and mirrors - Electrically heated and operated main and wide-angle rear view cameras with manually adjusted passenger kerb and front mirror and passenger corner pedestrian camera. <input type="checkbox"/> MIRCMS Camera monitoring and mirrors - Electrically heated and operated main and wide-angle rear view cameras with manually adjusted passenger kerb and front mirror <input checked="" type="checkbox"/> MIRCOMF Mirrors - Electrically heated and operated main and wide angle and manually adjusted passenger kerb and front mirror <input checked="" type="checkbox"/> AMIR-F20 Auxiliary front view mirror with a 200mm radius <input type="checkbox"/> SUNV-H External smoke grey sunvisor <input type="checkbox"/> AD-ROOF Cab roof deflector - Adjustable <input type="checkbox"/> AD-SIDEL Cab side deflector - Long extension panels <input type="checkbox"/> AD-SIDES Cab side deflector - Short extension panels <input type="checkbox"/> AD-CHASX Chassis side skirts - extended <input type="checkbox"/> ADCF-F Additional black edging on chassis side skirt <input checked="" type="checkbox"/> HL-LED Headlights - LED <input type="checkbox"/> HL-LED3 Headlights - LED Adaptive high beam <input checked="" type="checkbox"/> HL-CLEAN Headlight cleaner - Washer jets <input type="checkbox"/> HLP-ST Headlight protection <input type="checkbox"/> DRIVL2 Two spot lamps <input type="checkbox"/> UDRIVL Auxiliary driving lights - Without <input checked="" type="checkbox"/> FOGL-WC Front fog lights <input type="checkbox"/> CL-STAT Static corner lights <input type="checkbox"/> ASL-RF2 Integrated roof spotlights - Two LED aerodynamic spot lights in Globetrotter sign box <input type="checkbox"/> BEACOA2F Roof beacons - Two front roof mounted amber LED <input checked="" type="checkbox"/> BEACOA2R Roof beacons - Two rear roof mounted amber LED <input type="checkbox"/> BEACON-P Roof beacons - switch and wiring preparation only <input checked="" type="checkbox"/> BEACON4 Roof beacons - Four amber LED - two front/ two rear <input type="checkbox"/> CABPT-R1 Single outlet for roof mounted accessories <input checked="" type="checkbox"/> CABPT-R2 Twin outlets for roof mounted accessories. <input type="checkbox"/> SPOTP-F Spotlamp preparation in front, max 280W <input type="checkbox"/> SPOTP-R Spotlamp preparation on roof, max 280W <input type="checkbox"/> SPOTP-RF Spotlamp preparation on cab roof and in cab front, max 2x280W <input type="checkbox"/> ROS-IL2 Preparation kit for illuminated roof sign with switch loose in cab, fit after registration <input type="checkbox"/> CSGN-GTR Cab sign logo - Volvo "Globetrotter" or "Power" sign <input checked="" type="checkbox"/> HORN-F1S Horn - Air single tone - chassis mounted <input checked="" type="checkbox"/> HORN-R2S Horn - Air - Two roof-mounted <input type="checkbox"/> ANT-CBR Roof mounted antenna for CB radio, single aerial. Only Globetrotter cabs brings in extra DIN slots. <input type="checkbox"/> ACCBP-AP Front, middle & rear roof mounted accessory brackets <input type="checkbox"/> ACCBP-F Front roof mounted accessory bracket <input type="checkbox"/> ACCBP-FM Front & middle roof mounted accessory brackets <input type="checkbox"/> ACCBP-FR Front & rear roof mounted accessory brackets <input type="checkbox"/> ACCBP-M Middle roof mounted accessory bracket <input type="checkbox"/> ACCBP-R Rear roof mounted accessory bracket <input type="checkbox"/> ACCBP-RM Rear & middle roof mounted accessory brackets <input type="checkbox"/> STUC-B Left and right storage compartments under cab <input type="checkbox"/> STUC-L Left storage compartment under cab <input type="checkbox"/> STUC-R Right storage compartment under cab <input type="checkbox"/> RFCAR-BC Rear mudwing carrier, back of cab <input type="checkbox"/> LADDER Ladder back of cab <input type="checkbox"/> REFS-TW White cab conspicuity markings by packed in cab
--	--

CAB EXTERIOR

Standard Equipment Optional Equipment

For more detailed information about cab and powertrain equipment, please refer to separate specification sheets.

For all possible options and combinations of options please consult your Volvo sales contact who can create a specification to match your requirements using the Volvo Sales Support system (VSS).

The factory reserves the right to modify design and change equipment without previous notification. The specification can vary from country to country.

MODEL RANGE

FH 13 6x4 Tractor - Rear Air Suspension - N3 or N3G FH 64T 3A

<ul style="list-style-type: none"> <input type="checkbox"/> REFS-TY Yellow cab conspicuity markings by packed in cab <p>SUPERSTRUCTURE PREPARATIONS</p> <ul style="list-style-type: none"> <input type="checkbox"/> 5WM-ISHD Fifth wheel mount - Heavy-duty 80mm Z profiles with 16mm ISO plate - 96mm high above chassis frame ■ 5WM-ISOM Fifth wheel mount - 50mm L profiles with 10mm ISO plate - 60mm high above chassis frame <input type="checkbox"/> 5WM-MASM Fifth wheel mount - Manual slider with 50mm L profiles <input type="checkbox"/> 5WH150 Leg-height - 150 mm <input type="checkbox"/> 5WH185 Leg-height - 185 mm <input type="checkbox"/> 5WH190 Leg-height - 190 mm <input type="checkbox"/> 5WH290 Leg-height - 290 mm <input type="checkbox"/> 5WT-JO11 Fifth wheel - Jost JSK 38G cast heavy-duty <input type="checkbox"/> 5WT-JO8 Fifth wheel - Jost JSK 37 cast <input type="checkbox"/> 5WT-JO9 Fifth wheel - Jost JSK 42 cast <input type="checkbox"/> 5WT-JOHD Fifth wheel - Jost JSK 38C heavy-duty cast <input type="checkbox"/> 5WT-SH Fifth wheel - SAF-Holland/+GF+ SK-S 36.20 cast <input type="checkbox"/> 5WT-SH2 Fifth wheel - SAF-Holland/+GF+ SK-HD 38.36 cast heavy-duty <input type="checkbox"/> 5WL-S1 Fifthwheel lubrication - Locking mechanism and top plate <input type="checkbox"/> TCIND Trailer connection indicator - Sensors for height, kingpin and coupling lock ■ RDECK Catwalk - Single plate and step <input type="checkbox"/> RDECK-M Catwalk - Extended with two plates and step <input type="checkbox"/> SRWL-PK Chassis-mounted working lamps - Side work and reverse lamp preparation and 3 position switch - Max load 280W <input type="checkbox"/> SWL-2RW Chassis-mounted working lamps - Two white rear mounted LED lamps <input type="checkbox"/> SWL-PK Chassis-mounted working lamps - Side work lamp preparation and 2 position switch - Max load 280W ■ WL-TA1W Coupling light - LED White <input type="checkbox"/> WLC-H2W Working lamp back of cab - Two white LED high mounted at the back of cab <input type="checkbox"/> WLC-PKH Preparation kit, cables and switch for high mounted working lamps back of cab <input type="checkbox"/> WLC-PKL Preparation kit, cables and switch for low mounted working lamps back of cab <input type="checkbox"/> WLC-PKLH Preparation kit - cables and switch for low and high mounted working lamps back of cab. <input type="checkbox"/> ECBB-HIG Bodybuilder module - High level body electrical centre in dash input/output module ■ ECBB-MED Bodybuilder module - Medium level body electrical centre in dash input/output module <input type="checkbox"/> BBCHAS1 One 7-pole connector for Body builder interface <input type="checkbox"/> BBCHAS3 Three 7-pole connectors for Body builder interface <input type="checkbox"/> BEPR-T2 Body builder electrical software preparation for tipper with remote control <input type="checkbox"/> EXSTER External steering control - Volvo dynamic steering and bodybuilder module prepared for external control system, installed and computer by bodybuilder ■ TD-LED Trailer detection with LED sensing <input type="checkbox"/> AUXL-SPK Electrical preparation kit - wiring and switch for snow plough lights <input type="checkbox"/> TAILPRE2 Tail lift preparation kit, wireless remote operation <input type="checkbox"/> TAILPREP Taillift preparation kit - cab switch and warning in driver display <input type="checkbox"/> AESW2 Two Body builder bistable electrical switches (marked AUX1 / AUX2) <input type="checkbox"/> AESW2PK 2 Body builder bistable el.switches (marked AUX1/AUX2) and prep. for 4 more switches <input type="checkbox"/> AUXSW-4 Wiring for 4 extra switches (from Body builder electrical centre to switch positions) <p>DELIVERY SERVICES</p> <ul style="list-style-type: none"> ■ TGW-4GWL Telematics gateway - GSM/GPRS/4G modem, LTE & WLAN <input type="checkbox"/> FMS-PK Fleet management system gateway - Required for aftermarket telematics 	<ul style="list-style-type: none"> <input type="checkbox"/> DRUT1 Driver utility app - "My Truck" - 1 year subscription For mobile phone, tablet, with android and IOS systems. Only available with Volvo Connect subscription <input type="checkbox"/> DRUT2 Driver utility app - "My Truck" - 2 year subscription For mobile phone, tablet, with android and IOS systems. Only available with Volvo Connect subscription <input type="checkbox"/> DRUT3 Driver utility app - "My Truck" - 3 year subscription For mobile phone, tablet, with android and IOS systems. Only available with Volvo Connect subscription <input type="checkbox"/> DRUT4 Driver utility app - "My Truck" - 4 year subscription For mobile phone, tablet, with android and IOS systems. Only available with Volvo Connect subscription <input type="checkbox"/> DRUT5 Driver utility app - "My Truck" - 5 year subscription For mobile phone, tablet, with android and IOS systems. Only available with Volvo Connect subscription
--	--

■ Standard Equipment □ Optional Equipment

For more detailed information about cab and powertrain equipment, please refer to separate specification sheets.

For all possible options and combinations of options please consult your Volvo sales contact who can create a specification to match your requirements using the Volvo Sales Support system (VSS).

The factory reserves the right to modify design and change equipment without previous notification. The specification can vary from country to country.

MODEL RANGE

FH 13 6x4 Tractor - Rear Air Suspension - N3 or N3G FH 64T 3A

Volvo Trucks. Driving Progress