

# MODEL RANGE

FH D13 64 Rigid Diesel Rear Air FH 64R 3A

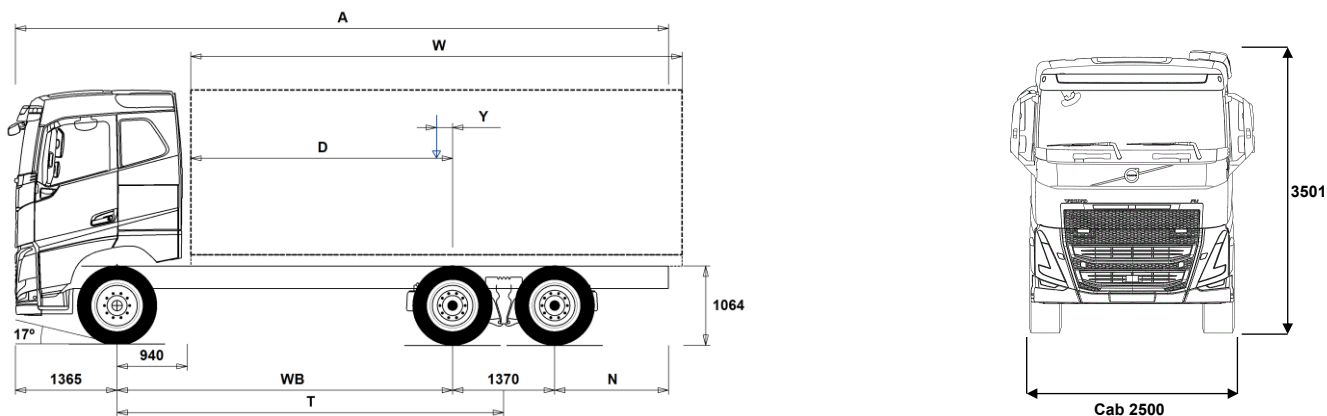

## Chassis Dimensions [mm]

| WB Wheelbase                           | 3200 | 3400 | 3700 | 3900 | 4300 | 4600 | 4900  | 5200  | 5600  |
|--|------|------|------|------|------|------|-------|-------|-------|
| A Overall Chassis Length               | 7710 | 7310 | 8460 | 8760 | 9410 | 9860 | 10310 | 10810 | 11410 |
| D Center of rear axle to front of body | 2210 | 2410 | 2710 | 2910 | 3310 | 3610 | 3910  | 4210  | 4610  |
| N Rear Overhang (Min.)                 | 825  | 825  | 825  | 825  | 825  | 825  | 1225  | 1225  | 1225  |
| N Rear Overhang (Max.)                 | 1775 | 1175 | 2025 | 2125 | 2375 | 2525 | 2675  | 2875  | 3075  |
| T Theoretical Wheelbase                | 3885 | 4085 | 4385 | 4585 | 4985 | 5285 | 5585  | 5885  | 6285  |
| Y Center of Gravity for Payload (Min.) | -233 | -222 | -183 | -162 | -121 | -96  | -64   | -33   | 4     |
| Y Center of Gravity for Payload (Max.) | -233 | -222 | -183 | -162 | -121 | -96  | -64   | -33   | 4     |
| W Body Length (Min.)                   | 4889 | 5266 | 5789 | 6147 | 6865 | 7414 | 7951  | 8489  | 9215  |
| W Body Length (Max.)                   | 4889 | 5266 | 5789 | 6147 | 6865 | 7414 | 7951  | 8489  | 9215  |

## Chassis Weights [kg]

|  |       |       |       |       |       |       |       |       |       |
|--|-------|-------|-------|-------|-------|-------|-------|-------|-------|
| Front Axle                                   | 4960  | 5005  | 5000  | 5010  | 5030  | 5070  | 5075  | 5085  | 5115  |
| Rear Bogie                                   | 3425  | 3380  | 3470  | 3475  | 3520  | 3580  | 3580  | 3595  | 3635  |
| Kerb Weight                                  | 8385  | 8385  | 8470  | 8485  | 8550  | 8650  | 8655  | 8680  | 8750  |
| Payload (including body, driver, fuel, etc.) | 17615 | 17615 | 17530 | 17515 | 17450 | 17350 | 17345 | 17320 | 17250 |

## Turning Diameter [mm]

|                                      |       |       |       |       |       |       |       |       |       |
|--------------------------------------|-------|-------|-------|-------|-------|-------|-------|-------|-------|
| Turning Circle Diameter Kerb to Kerb | 13900 | 14500 | 15500 | 16100 | 17300 | 18200 | 19100 | 20000 | 21300 |
| Turning Circle Diameter Wall to Wall | 15300 | 15900 | 16800 | 17400 | 18700 | 19600 | 20500 | 21400 | 22600 |

## Plated Weights [kg]

|                          | Plated | Design |
|--------------------------|--------|--------|
| Gross Vehicle Weight     | 26000  | 28100  |
| Gross Combination Weight | 0      | 44000  |
| Front Axle               | 7000   | 7100   |
| Rear Bogie               | 19000  | 21000  |

## Important Notes

### Chassis Dimensions

Cab Height: +305 mm for CAB-HSLP, -285 mm for CAB-LSLP, +450 mm for CAB-XHSL.

Front Axle to Back of Cab: +141 mm for CAB-LSLP.

D-measure includes a front clearance of 50 mm and for rigid trucks also a subframe of 100 mm.

Height can vary ± 20 mm for leaf and ± 10 mm for air suspension.

All dimensions are for unladen chassis and any tag axles down. Chassis height used: CHH-HIGH.

Rear overhang used for vehicle weight calculation is the maximum rear overhang (N Max.) for selected wheelbase.

Height change when chassis height CHH-MED,FRAME300: 0 mm.

Weight and dimensions are based upon the following tyres:

Front Axle Tyres: 315/80R22.5

Drive Axle Tyres: 315/80R22.5

**Chassis weight includes oil, water, AdBlue, 0 litres fuel and without driver. Kerb weight can vary ± 3%.**

Turning diameters are theoretically calculated.

Legal weights can differ from country to country.

For more detailed weight information, including optional equipment weights, ask your Volvo sales contact to enter your specification into the Volvo Weight Information system (WIS).

Do NOT use this drawing for bodybuilding. Refer to Volvo Bodybuilder Instructions and chassis assembly drawing FH64R3A.

# MODEL RANGE

## FH D13 64 Rigid Diesel Rear Air FH 64R 3A

### Transport operation

- RC-ROUGH** Rough road conditions: frequent driving on poorly maintained surfaced roads, hard-packed sand or gravel, or other surfaces of good or bad quality.
- RC-SMOOT** Smooth road conditions: at least 95% of the driven distance is on well-maintained or less maintained surfaced roads. Driving may occur on poorly maintained surfaced roads, hard-packed sand, or gravel surfaces of good or bad quality.
- SWAPBODY** Swap body vehicle preparation
- TIPP-PRE** Tipper vehicle preparation
- UNIFORM** Basic platform vehicle

### Core components

- CHH-HIGH** Chassis height high - approx. 1000 mm above ground level
- CHH-MED** Chassis height medium - approx. 900 mm above ground level
- RADD-GR** Rear air suspension - two axles, both driving
- FH-AHSLP** FH Aero Globetrotter, high sleeper cab
- FH-ALSLP** FH Aero low sleeper cab
- FH-ASLP** FH Aero sleeper cab
- FH-AXHSL** FH Aero Globetrotter XL, extra-high sleeper cab
- FH-HSLP6** FH Globetrotter, high sleeper cab
- FH-LSLP6** FH low sleeper cab
- FH-SLP6** FH sleeper cab
- FH-XHSL6** FH Globetrotter XL, extra-high sleeper cab
- EU3** Euro 3 emission level
- EU4SCR** Euro 4 with Selective Catalytic Reduction (SCR)
- EU5SCR-M** Euro 5 with Selective Catalytic Reduction (SCR)
- EU6SCR** Euro 6 with SCR, particulate filter and EGR, Turbo-S
- D13S420A** Diesel engine, Euro 6, 12.8 litres, 420 hp/309 kW, 2100 Nm
- D13S460A** Diesel engine, Euro 6, 12.8 litres, 460 hp/338 kW, 2300 Nm
- D13S500A** Diesel engine, Euro 6, 12.8 litres, 500 hp/368 kW, 2500 Nm
- D13S540A** Diesel engine, Euro 6, 12.8 litres, 540 hp/397 kW, 2600 Nm
- D13T420A** Diesel engine, Euro 6, 12.8 litres, 420 hp/309 kW, 2400 Nm with turbocompound
- D13T460A** Diesel engine, Euro 6, 12.8 litres, 460 hp/338 kW, 2630 Nm with turbocompound
- D13T480A** Biodiesel engine, Euro 6, 12.8 litres, 480 hp/353 kW, 2700 Nm with turbocompound
- D13T500A** Diesel engine, Euro 6, 12.8 litres, 500 hp/368 kW, 2810 Nm with turbocompound
- D13A400** Diesel engine, Euro 3, 12.8 litres, 400 hp/294 kW, 2000 Nm
- D13A420** Diesel engine, Euro 4, 12.8 litres, 420 hp/309 kW, 2100 Nm
- D13A440** Diesel engine, Euro 3, 12.8 litres, 440 hp/324 kW, 2200 Nm
- D13A460** Diesel engine, Euro 4, 12.8 litres, 460 hp/338 kW, 2300 Nm
- D13A480** Diesel engine, Euro 3, 12.8 litres, 480 hp/353 kW, 2400 Nm
- D13A500** Diesel engine, Euro 4, 12.8 litres, 500 hp/368 kW, 2500 Nm
- D13A520** Diesel engine, Euro 3, 12.8 litres, 520 hp/382 kW, 2500 Nm
- D13A540** Diesel engine, Euro 4, 12.8 litres, 540 hp/397 kW, 2600 Nm
- D13C420** Diesel engine, Euro 5, 12.8 litres, 420 hp/309 kW, 2100 Nm
- D13C460** Diesel engine, Euro 5, 12.8 litres, 460 hp/338 kW, 2300 Nm
- D13C500** Diesel engine, Euro 5, 12.8 litres, 500 hp/368 kW, 2500 Nm
- D13C540** Diesel engine, Euro 5, 12.8 litres, 540 hp/397 kW, 2600 Nm
- D13K420** Diesel engine, Euro 6, 12.8 litres, 420 hp/309 kW
- D13K460** Diesel engine, Euro 6, 12.8 litres, 460 hp/338 kW
- D13K500** Diesel engine, Euro 6, 12.8 litres, 500 hp/368 kW
- D13K540** Diesel engine, Euro 6, 12.8 litres, 540 hp/397 kW
- EBR-VEB** Volvo Engine Brake, VEB (compression brake with exhaust pressure governor, EPG)
- EBR-VEB+** Volvo Engine Brake, VEB+ (high efficiency compression brake with exhaust pressure governor, EPG)
- AT2412** I-Shift automated 12-speed gearbox, 2400 Nm
- AT2612** I-Shift automated 12-speed gearbox, 2600 Nm
- AT2812** I-Shift automated 12-speed gearbox, 2800 Nm
- ATO2612** I-Shift automated 12-speed gearbox with overdrive, 2600 Nm
- ATO3112** I-Shift automated 12-speed gearbox with overdrive, 3100 Nm
- ASO-C** One crawler gear
- ASO-ULC** Two crawler gears, one crawler and one ultra-low crawler
- TAAXLIFT** Tandem Axle Lift for driven bogie axle

- RTH2610B** Rear hub reduction tandem axle - bogie load 26 tonnes, GCW 100 tonnes, 4 planet gears
- RTH2610F** Rear hub reduction tandem axle - bogie load 26 tonnes, GCW 100 tonnes, version F
- RTS2310A** Rear single reduction tandem axles - bogie load 23 tonnes, GCW 100 tonnes
- RTS2370A** Rear single reduction tandem axle - bogie load 23 tonnes, GCW 70 tonnes

### Packages

- FP-D13** Fuel economy package for Euro 6 D13 engine
- INFOBASE** Information package, basic (without side display)
- INFOHIGH** Information package, high (with side display)
- SAFEBAS** Active Safety Basic package (outside Europe)
- SAFEBAS2** Active Safety Basic package (outside Europe)
- SAFEPLU2** Active Safety Plus package (outside Europe)
- SAFEPLUS** Active Safety Plus package (outside Europe)

### Chassis

- FST-AIR** Front air suspension
- FST-PAR** Two-leaf front parabolic springs (normal stiffness)
- FST-PAR3** Three-leaf front parabolic springs (stiffer than normal)
- FST-PL1** Two-leaf front parabolic springs, lightweight composite support leaf (normal stiffness)
- FSLs-BAS** Basic levelling stroke in front air suspension (high ground clearance under front axle member)
- FSLs-HI** High-range levelling stroke in front air susp. (reduced ground clearance under front axle member)
- FAL10.0** Front axle load 10.0 tonnes
- FAL7.1** Front axle load 7.1 tonnes
- FAL7.5** Front axle load 7.5 tonnes
- FAL8.0** Front axle load 8.0 tonnes
- FAL8.5** Front axle load 8.5 tonnes
- FAL9.0** Front axle load 9.0 tonnes
- FSTAB** Front anti-roll bar, normal stiffness
- FSTAB2** Front anti-roll bar, high stiffness
- FSTAB3** Front anti-roll bar, extra-high stiffness
- RAL21** Rear axles load 21 tonnes
- RAL23** Rear axles load 23 tonnes
- RAL26** Rear axles load 26 tonnes
- RSTAB1** Rear anti-roll bar, normal stiffness
- RSTAB3** Rear anti-roll bar, extra-high stiffness
- RALIM105** First rear driving axle load limiter, 10.5 tonnes (speed controlled)
- RALIM115** First rear driving axle load limiter, 11.5 tonnes (speed controlled)
- RALIM13** First rear drive axle load limiter, 13 tonnes
- RALIM15** First rear driving axle load limiter, 15 tonnes
- RALIM95** First rear driving axle load limiter, 9.5 tonnes (speed controlled)
- ASF-DL1** Air suspension with one ride height
- ASF-DL3** Air suspension with three ride heights
- ACTST-TO** Volvo Dynamic Steering
- ASFE-BAS** Volvo Dynamic Steering, basic
- ASFE-OG** Volvo Dynamic Steering with Stability Assist
- ASFE-PO** Volvo Dynamic Steering with Personal Settings and Stability Assist
- ASFE-PS** Volvo Dynamic Steering with Personal Settings
- PSP-FIX** Power steering pump with fixed displacement
- PSP-VAR** Power steering pump with variable displacement
- PSP-VAR2** Power steering pump with variable displacement (extra valve)
- EBS-MED** EBS (Electronic Braking System), Medium package
- EBS-STD** EBS (Electronic Braking System), Standard package
- AUXPARK** Extra parking brake on one axle
- RST-AIR** Rear air springs
- RST-AIR6** Rear air springs for hot climates
- FRAME266** Frame rail section external height 266 mm

Standard Equipment       Optional Equipment

For more detailed information about cab and powertrain equipment, please refer to separate specification sheets.

For all possible options and combinations of options please consult your Volvo sales contact who can create a specification to match your requirements using the Volvo Sales Support system (VSS).

The factory reserves the right to modify design and change equipment without previous notification. The specification can vary from country to country.

# MODEL RANGE

## FH D13 64 Rigid Diesel Rear Air FH 64R 3A

|  |  |
|--|--|
| <ul style="list-style-type: none"> <li>■ <b>FRAME300</b> Frame rail section external height 300 mm</li> <li>□ <b>FST7070</b> Frame thickness - web 7.0 mm / flange 7.0 mm</li> <li>□ <b>FST8080</b> Frame thickness - web 8.0 mm / flange 8.0 mm</li> <li>□ <b>FIL-EEEE</b> Frame inner liner from end of engine to end of bogie</li> <li>□ <b>FIL-EEEE</b> Frame inner liner from end of engine to end of frame</li> <li>□ <b>FIL-FBEB</b> Frame inner liner from front of bogie to end of bogie</li> <li>□ <b>FIL-FBEB</b> Frame inner liner from front of bogie to end of frame</li> <li>□ <b>FIL-TXEB</b> Frame inner liner from transmission cross member to end of bogie</li> <li>□ <b>FIL-TXEF</b> Frame inner liner from transmission cross member to end of frame</li> <li>■ <b>BBOX-L</b> Battery box on left-hand side</li> <li>■ <b>BATS-S</b> Single battery system (2 batteries)</li> <li>□ <b>2BAT210C</b> AGM batteries, 2x210 Ah</li> <li>■ <b>2BATT170</b> Batteries, 2x170 Ah</li> <li>□ <b>2BATT225</b> Batteries, 2x225 Ah</li> <li>■ <b>BATTAMP</b> Battery voltmeter and ammeter</li> <li>□ <b>BATTIND</b> Battery voltmeter, ammeter and battery status gauge with visual alerts</li> <li>□ <b>ADR1</b> ADR adaptation, 1 switch in dashboard</li> <li>□ <b>ADR2</b> ADR adaptation, 1 switch in dashboard, 1 outside on back of cab</li> <li>□ <b>MSWI-A</b> ADR main switch</li> <li>■ <b>MSWI-C</b> Main switch on chassis</li> <li>□ <b>MSWI-R</b> Key remote controlled main switch</li> <li>■ <b>R405A71</b> Right 405-litre, D-shaped aluminium fuel tank, 710 mm high<br/>Min volume 255l<br/>Max volume 810l</li> <li>■ <b>UL-FUEL</b> Without left side fuel tank<br/>Min volume 160l<br/>Max volume 730l</li> <li>□ <b>ADTP-L</b> AdBlue tank on left hand side</li> <li>■ <b>ADTP-R</b> AdBlue tank on right hand side</li> <li>□ <b>ADB048</b> AdBlue tank: usable volume 48 litres, 560 mm high, mounted on chassis side</li> <li>■ <b>ADB064</b> AdBlue tank: usable volume 64 litres, 710 mm high, mounted on chassis side</li> <li>□ <b>ADB068</b> AdBlue tank: usable volume 68 litres, 560 mm high, mounted on chassis side</li> <li>□ <b>ADB083</b> AdBlue tank: usable volume 83 litres, 560 mm high, mounted on chassis side</li> <li>□ <b>ADB090</b> AdBlue tank: usable volume 90 litres, 710 mm high, mounted on chassis side</li> <li>□ <b>ADB100</b> AdBlue tank: usable volume 100 litres, 710 mm high, mounted on chassis side</li> <li>□ <b>ADB112</b> AdBlue tank: usable volume 112 litres, 710 mm high, mounted on chassis side</li> <li>□ <b>ADTC-BF</b> AdBlue tank cover, silver metallic</li> <li>■ <b>FCAP-L</b> Lockable diesel and AdBlue filler caps</li> <li>■ <b>FUFF-AS</b> Fuel filling anti-spillage device</li> <li>□ <b>FUFF-ATS</b> Fuel filling anti-theft and anti-spillage device</li> <li>□ <b>ESH-LEFT</b> Horizontal silencer, left exhaust outlet</li> <li>■ <b>ESH-REAR</b> Horizontal silencer, rear exhaust outlet</li> <li>□ <b>ESH-RIGH</b> Horizontal silencer, right exhaust outlet</li> <li>□ <b>ESH-VERT</b> Horizontal silencer, vertical exhaust outlet on right-hand side</li> <li>□ <b>ESV-VERT</b> Vertical silencer, vertical exhaust outlet on right-hand side</li> <li>□ <b>EXST-SSP</b> Vertical exhaust top pipe, bright polished stainless steel</li> <li>□ <b>EXST-ST</b> Vertical exhaust top pipe, aluminised steel</li> <li>□ <b>HS-NAR</b> Muffler heat shield (EATS), narrow</li> <li>□ <b>WHC-FIX2</b> Two non-collapsible wheel chocks</li> <li>■ <b>WHC-FOL2</b> Two collapsible wheel chocks</li> <li>□ <b>WHCP-F</b> Wheel chock holder in the front part of the vehicle</li> <li>□ <b>WHCP-M</b> Wheel chock holder in the middle part of the vehicle</li> <li>□ <b>WHCP-R</b> Wheel chock holder in the rear part of the vehicle</li> </ul> | <ul style="list-style-type: none"> <li>■ <b>WHCP-T</b> Wheel chock holder by-packed in cab outer luggage compartment</li> <li>□ <b>TB-L80</b> Tool box on left-hand side, 205-litre - width 730 mm, height 590, depth 595 mm</li> <li>□ <b>TB-R80</b> Tool box on right-hand side, 205-litre - width 730 mm, height 590, depth 595 mm</li> <li>□ <b>SUP-BAS</b> Standard side underrun protection, aluminium</li> <li>□ <b>CHAIN-S</b> Snow chains</li> <li>□ <b>HOOK-SC</b> Snow chain hooks</li> <li>■ <b>TOWF-NO1</b> One front towing device</li> <li>□ <b>TOWF-NO2</b> Two front towing devices</li> <li>□ <b>TOWMBRH</b> Towing member, high-mounted in centre of frame</li> <li>□ <b>TOWMBRL1</b> Towing member, low-mounted under frame</li> <li>□ <b>TOWMBRL2</b> Towing member, low and forward-mounted under frame</li> <li>□ <b>TOWMBRL3</b> Towing member, low and far-forward-mounted under frame</li> <li>□ <b>TOWMBRM</b> Towing member, medium-mounted in line with lower frame flange</li> <li>□ <b>RFEC-L</b> Tapered lower rear frame end (for centre axle drawbar)</li> <li>■ <b>RFEC-S</b> Straight-cut rear frame end</li> <li>□ <b>RFEC-U</b> Upper corner cut on rear frame end (for e.g. tipper, refuse and hook lift applications)</li> <li>□ <b>C-RI4040</b> Coupling Ringfeder 4040A G-150</li> <li>□ <b>C-RI4045</b> Coupling Ringfeder 4045A G-150</li> <li>□ <b>C-RI5050</b> Coupling Ringfeder 5050A G-150</li> <li>□ <b>C-RO400G</b> Coupling Rockinger 400 G-150</li> <li>□ <b>C-RO50</b> Coupling Rockinger 50 mm</li> <li>□ <b>C-VBG520</b> Coupling VBG 5200D</li> <li>□ <b>C-VBG795</b> Coupling VBG 795V</li> <li>□ <b>TOWR-ONE</b> Brace that can be used for towing in specific situations. The brace is mounted on the end cross member, and if the end cross member is thinner than 8 mm, it will be reinforced. The brace includes a lockable pin and is dimensioned for a 3-tonne centre-axle trailer or a 10-tonne articulated drawbar trailer. It may only be used for short-distance, on-site transport in confined areas and at speeds of a maximum of 30 km/h.</li> <li>□ <b>TREL-PK</b> Trailer electrical preparation kit (chassis/cab wiring)</li> <li>□ <b>TREL14</b> 14-pin trailer connection</li> <li>□ <b>TREL15</b> 15-pin trailer connection (ADR certified)</li> <li>□ <b>TREL7</b> 7-pin trailer connection (ISO 24N)</li> <li>□ <b>TREL7-7</b> 2x7-pin trailer connection (ISO 24N+24S, non-ADR)</li> <li>□ <b>TBC-EC</b> Trailer brake connection, European Community</li> <li>□ <b>TRBR-HCF</b> Full-pressure, hand-controlled trailer brake check (8 bar)</li> <li>□ <b>TRBR-HCR</b> Reduced-pressure, hand-controlled trailer brake check (4 bar)</li> <li>□ <b>TRBR-STA</b> Stationary trailer brake check</li> <li>□ <b>TRB-STRE</b> Stretch brake, trailer brake activation at low speeds to avoid jack-knifing and improve stability</li> <li>□ <b>RUP-FOLD</b></li> <li>□ <b>RFEND-B</b> Rear 3-piece mudguards (anti-spray) on all rear axles</li> <li>□ <b>RFEND-T</b> Transport mudguard</li> <li>□ <b>RFH-BAS</b> Basic mudguard installation height on 2nd front axle and rear axles</li> <li>□ <b>RFH-HIG</b> High mudguard installation height on 2nd front axle and rear axles</li> <li>□ <b>RFH-LOW</b> Low mudguard installation height on 2nd front axle and rear axles</li> <li>□ <b>AUXATNK</b> Extra air tank for air suspension</li> <li>□ <b>ATANK-AL</b> Aluminium air tanks</li> <li>■ <b>ATANK-ST</b> Steel air tanks</li> <li>□ <b>TL-LED</b> LED tail lamps (tail light, exterior marker light, brake light, hazard warning light, reverse light, rear fog light, licence plate light and reflector)</li> <li>■ <b>BLIGHT-E</b> Flashing brake lights will automatically activate in emergency braking. The flashing frequency is 4 Hz and emergency braking is detected if speed exceeds 50 km/h and retardation</li> </ul> |
|--|--|

■ Standard Equipment      □ Optional Equipment

For more detailed information about cab and powertrain equipment, please refer to separate specification sheets.

For all possible options and combinations of options please consult your Volvo sales contact who can create a specification to match your requirements using the Volvo Sales Support system (VSS).

The factory reserves the right to modify design and change equipment without previous notification. The specification can vary from country to country.

# MODEL RANGE

## FH D13 64 Rigid Diesel Rear Air FH 64R 3A

is 4 m/s<sup>2</sup> or more. The function deactivates when retardation is less than 2.5 m/s<sup>2</sup>.

### Rims and tyres

- RT-AL** Brushed aluminium rims with standard holes (long stud fixing) on all axles
  - RT-AL1** LvL ONE® smooth and glossy aluminium rims with standard holes (long stud fixing) on all axles
  - RT-AL1DU** LvL ONE® smooth and glossy aluminium rims with countersunk holes (short stud fixing) on all axles
  - RT-ALDP** Dura-Bright® polished aluminium rims with standard holes (long stud fixing) on all axles
  - RT-ALDPD** Dura-Bright® polished aluminium rims with countersunk holes (short stud fixing) on all axles
  - RT-ALDU** Brushed aluminium rims with countersunk holes (short stud fixing) on all axles
  - RT-STEEL** Steel rims on all axles
  - WCAP** Wheel caps
  - SPWT-D** Spare driving wheel
  - SPWT-F** Spare front wheel
  - SWCP-LF** Spare wheel carrier on left side in front of rear axle
  - SWCP-R** Spare wheel carrier mounted behind rear axle
  - SWCP-T** Spare wheel transport-mounted on top of frame
  - SWCP-TP** Spare wheel and carrier transport-mounted on top of frame
  - JACK-12T** Hydraulic jack, 12 tonnes. Low manual pumping force facilitates use in uncomfortable positions. Has a release valve, which permits safe, easy and precise control over rate of lowering and a filter in the oil reservoir gives protection from contamination.  
Height 180-315 mm, weight 7.0 kg
  - JACK-15T** Hydraulic jack, 15 tonnes. Low manual pumping force facilitates use in uncomfortable positions. Has a release valve, which permits safe, easy and precise control over rate of lowering and a filter in the oil reservoir gives protection from contamination.  
Height 225-438 mm, weight 9.4 kg
  - JACK-20T** Hydraulic jack, 20 tonnes. Low manual pumping force facilitates use in uncomfortable positions. Has a release valve, which permits safe, easy and precise control over rate of lowering and a filter in the oil reservoir gives protection from contamination.  
For FM: Height 190-325 mm, weight 10.5 kg  
For FH: height 240-467 mm, weight 13.3. kg
  - TOOLKIT** This kit consists of a tool bag (case) including the following tools:
    - Combination screwdriver.
    - 1 screwdriver handle
    - 1 blade, Philips/flat blade
    - 1 blade, Torx T10/Torx T20
    - 1 blade, Torx T25/Torx T27
    - 1 blade, Torx T30/Torx T40
    - Socket wrench.
    - Adjustable pliers.
    - Allen key.
    - Adjustable spanner.
    - Hammer.
  - INFLAHOS** Tyre inflation hose 18 m. The air is supplied by a chassis-mounted pneumatic outlet (must be ordered separately).
  - GAUGE-TP** Tyre pressure gauge
- ### Powertrain equipment
- TRAP-HD** Reinforced gearbox range housing
  - DRM-BE** I-Shift drive modes Economy, Standard and Performance
  - DRM-E** I-Shift drive mode Economy
  - PVT-MTM** I-See
  - CRUIS-E** I-Cruise cruise control, I-Roll included
  - CRUIS-E5** I-Torque cruise control, optimized for fuel economy, I-Roll included

- AMSO-AUT** I-Shift manual gear shifting available in automatic mode, including kick-down function
- AVO-ENH** I-Shift with enhanced software for construction and off-road applications
- APF-ENH** I-Shift with enhanced PTO functions (Auto neutral for p. brake/Reverse inhibit/Split box connection)
- RET-TH** Gearbox-mounted, hydrodynamic oil retarder
- TC-MAOH2** Extra high performance cooler for manual/I-shift gearboxes - air/oil
- TC-MWO** Basic performance cooler for manual/I-Shift gearboxes - water/oil
- TC-MWOH2** High performance cooler for manual/I-Shift gearboxes - water/oil
- 2COM1080** Dual-cylinder air compressor 704 cc, 1080 l/min
- 2COM1100** Dual-cylinder air compressor 760 cc, 1100 l/min
- 2COMP870** Dual-cylinder, two-stage air compressor 560 cc, 870 l/min
- 2COMP900** Dual-cylinder air compressor 636 cc, 900 l/min
- CLU-AIRC** Air compressor clutch with automatic declutching when not needed, to save fuel
- AIRIN-FR** Front air inlet
- AIRIN-HI** High air inlet
- AIRIN-LO** Low air inlet
- ACL1ST-S** Air cleaner with extra filter element
- 24A150BL** Alternator 150 Ampere
- 24A180BL** Alternator 180 Ampere
- 24AL110B** Alternator 110 Ampere
- 24AL150B** Alternator 150 Ampere
- CCV-C** Closed crankcase ventilation
- CCV-O** Open crankcase ventilation
- CCV-OX** Open extended crankcase ventilation with oil separator and maintenance-free gas centrifuge
- FUEQ-EH** Fuel line electric heater
- AF-E** Electrically heated fuel filter
- AF-R** Hot fuel recirculation heated fuel filter
- FUEFE2LW** Large engine-mounted dual fuel filter with water separator and drain
- FUEFE2SW** Small engine-mounted dual fuel filter with water separator and drain (for good fuel quality)
- EST-AID** Engine intake air heater
- 220EBH15** Engine block heater, 220 V, 1.5 kW
- PTER-100** Rear engine, clutch-independent PTO, flange connection, DIN 100/ISO 7646
- PTER-DIN** Rear engine, clutch-ind. PTO, splined shaft groove (fem), close-coupled pump DIN 5462/ISO7653
- PTER1400** Rear engine, clutch-independent PTO, flange connection, SAE 1410/ISO 7647
- HPE-F101** Engine-mounted hydraulic pump F1-101, fixed displacement, single flow
- HPE-F41** Engine-mounted hydraulic pump F1-41, fixed displacement, single flow
- HPE-F51** Engine-mounted hydraulic pump F1-51, fixed displacement, single flow
- HPE-F61** Engine-mounted hydraulic pump F1-61, fixed displacement, single flow
- HPE-F81** Engine-mounted hydraulic pump F1-81, fixed displacement, single flow
- HPE-T53** Engine-mounted hydraulic pump F2-53/53, fixed displacement, twin flow
- HPE-T70** Engine-mounted hydraulic pump F2-70/35, fixed displacement, twin flow
- HPE-V45** Engine-mounted hydraulic pump VP1-45, variable displacement, single flow
- HPE-V75** Engine-mounted hydraulic pump VP1-75, variable displacement, single flow

Standard Equipment       Optional Equipment

For more detailed information about cab and powertrain equipment, please refer to separate specification sheets.

For all possible options and combinations of options please consult your Volvo sales contact who can create a specification to match your requirements using the Volvo Sales Support system (VSS).

The factory reserves the right to modify design and change equipment without previous notification. The specification can vary from country to country.

# MODEL RANGE

## FH D13 64 Rigid Diesel Rear Air FH 64R 3A

|   |  |   |   |
|---|--|---|---|
| <input type="checkbox"/> <b>PTR-D</b>                         | Gearbox low-speed PTO, 1 rear connection DIN 5462/ISO 7653 for plug-in pump, 1000 Nm   | <input type="checkbox"/> <b>CU-ECC2</b>             | Automatic climate control with sun sensor, humidity sensor, air quality sensor and carbon filter  |
| <input type="checkbox"/> <b>PTR-DH</b>                        | Gearbox high-speed PTO, 1 rear connection DIN 5462/ISO 7653 for plug-in pump, 600 Nm   | <input checked="" type="checkbox"/> <b>CU-MCC</b>   | Manual climate control (heater/cooler function)   |
| <input type="checkbox"/> <b>PTR-DM</b>                        | Gearbox medium-speed PTO, 1 rear connection DIN 5462/ISO 7653 for plug-in pump, 600 Nm   | <input checked="" type="checkbox"/> <b>IGT-BUT</b>  | Push button ignition  |
| <input type="checkbox"/> <b>PTR-F</b>                         | Gearbox low-speed PTO, 1 rear flange connection SAE 1410/ISO 7647 for propshaft, 1000 Nm   | <input type="checkbox"/> <b>IMMOBIL</b>             | Immobiliser   |
| <input type="checkbox"/> <b>PTR-FH</b>                        | Gearbox high-speed PTO, 1 rear flange connection SAE 1310/ISO 7647 for propshaft, 600 Nm   | <input type="checkbox"/> <b>ALARM-E</b>             | Anti-theft alarm for cab, superstructure and trailer  |
| <input type="checkbox"/> <b>PTR-FL</b>                        | Gearbox low-speed PTO, 1 rear flange connection SAE 1310/ISO 7647 for propshaft, 600 Nm  | <input type="checkbox"/> <b>AUD-EXT</b>             | Extended audio system including amplifier and subwoofer   |
| <input type="checkbox"/> <b>PTRD-D</b>                        | Gearbox high-speed PTO, 1 rear + 1 front DIN 5462/ISO 7653 for plug-in pumps, 870 Nm   | <input type="checkbox"/> <b>PHONE-PK</b>            |   |
| <input type="checkbox"/> <b>PTRD-D1</b>                       | Gearbox high-speed PTO, 1 rear SAE 1410/ISO 7647, 1 front DIN5462/ISO7653, 870 Nm  | <input type="checkbox"/> <b>ISUNS-BS</b>            | Side interior roller blind on both sides, manually manoeuvred   |
| <input type="checkbox"/> <b>PTRD-D2</b>                       | Gearbox PTO, 2 rear hi/lo-speed SAE1310/1410/ISO7647, 1 front hi-speed DIN5462/ISO7653, 870/1000 Nm  | <input checked="" type="checkbox"/> <b>ISUNS-DS</b> | Side interior roller blind on driver's side, manually manoeuvred  |
| <input type="checkbox"/> <b>PTRD-F</b>                        | Gearbox high-speed PTO, 1 rear flange connection SAE 1410/ISO 7647 for propshaft, 870 Nm   | <input type="checkbox"/> <b>ISUNF-RE</b>            | Interior roller blind, integrated in front shelf, electrically manoeuvred   |
| <input type="checkbox"/> <b>HPG-F101</b>                      | Gearbox-mounted hydraulic pump F1-101, fixed displacement, single flow   | <input checked="" type="checkbox"/> <b>ISUNF-RM</b> | Interior roller blind, integrated in front shelf, manually manoeuvred   |
| <input type="checkbox"/> <b>HPG-F41</b>                       | Gearbox-mounted hydraulic pump F1-41, fixed displacement, single flow  | <input checked="" type="checkbox"/> <b>CSPL-BX</b>  | Open storage in lower centre instrument panel   |
| <input type="checkbox"/> <b>HPG-F51</b>                       | Gearbox-mounted hydraulic pump F1-51, fixed displacement, single flow  | <input type="checkbox"/> <b>CSPL-BXD</b>            | Storage drawer in lower centre instrument panel   |
| <input type="checkbox"/> <b>HPG-F61</b>                       | Gearbox-mounted hydraulic pump F1-61, fixed displacement, single flow  | <input type="checkbox"/> <b>ADFS</b>                | Two extra DIN slots in front shelf, 165x40x180 mm (W x H x D)   |
| <input type="checkbox"/> <b>HPG-F81</b>                       | Gearbox-mounted hydraulic pump F1-81, fixed displacement, single flow  | <input checked="" type="checkbox"/> <b>BUPALARM</b> | Reversing warning   |
| <b>Cab Interior, Driving</b>                                  |  | <input type="checkbox"/> <b>LOADIND</b>             | Load indicator, shown in instrument display and side display  |
| <input checked="" type="checkbox"/> <b>STWPOS-L</b>           | Left-hand drive  | <input type="checkbox"/> <b>REMC-MF</b>             | Wireless remote control, multi-functional   |
| <input type="checkbox"/> <b>STWPOS-R</b>                      | Right-hand drive   | <input checked="" type="checkbox"/> <b>FIREXT3S</b> | Fire extinguisher 3 kg, Swedish/English decal   |
| <input type="checkbox"/> <b>STWM-LE</b>                       | Steering wheel material leather  | <input checked="" type="checkbox"/> <b>WARNVEST</b> | Reflective vest, fulfils European standard EN 471 class 2   |
| <input type="checkbox"/> <b>STGW-AD2</b>                      | Manually adjustable steering wheel with neck tilt  | <input checked="" type="checkbox"/> <b>WARNTRI2</b> | Two warning triangles   |
| <input checked="" type="checkbox"/> <b>STGW-ADJ</b>           | Manually adjustable steering wheel   | <input type="checkbox"/> <b>AIDKIT</b>              | First aid kit containing sticking plaster, washing and drying pads, compresses, elastic bandages, respiratory mask, gloves and scissors.  |
| <input type="checkbox"/> <b>AIRBAG</b>                        | Airbag on driver's side  | <input type="checkbox"/> <b>AIDKIT1B</b>            | First aid kit containing sticking plaster, compresses, elastic bandages, gloves, scissors, triangular bandage, bandaging cloths, adhesive tape and rescue sheet (German requirements) |
| <input type="checkbox"/> <b>DRC-AMII</b>                      | Regeneration control for DPF, initiation: automatic or manual, inhibition: manual  | <input type="checkbox"/> <b>WARNLAMP</b>            | Portable amber and white warning lamp with batteries  |
| <input checked="" type="checkbox"/> <b>DRC-AUTO</b>           | Regeneration control for DPF, fully automatic (in motion)  | <input type="checkbox"/> <b>LAMP-IN</b>             | Inspection lamp with 10 m cable   |
| <input type="checkbox"/> <b>1DAYB</b>                         | One-day analogue tachograph, basic   | <input type="checkbox"/> <b>BULBKIT</b>             | Bulb and fuse kit   |
| <input checked="" type="checkbox"/> <b>TAC-PK2</b>            | Preparation kit for tachograph   | <input type="checkbox"/> <b>WRITEPAD</b>            | Writing pad with paper clamp  |
| <input type="checkbox"/> <b>ARSL</b>                          | Additional road speed limiter control (switch in dashboard)  | <b>Cab Interior, Living</b>                         |   |
| <input checked="" type="checkbox"/> <b>ACCLF-D</b>            | Volvo torque assist - Disabled   | <input type="checkbox"/> <b>DST-CF1</b>             | Driver's seat Comfort   |
| <input type="checkbox"/> <b>ACCLF-E</b>                       | Volvo torque assist - Enabled  | <input checked="" type="checkbox"/> <b>DST-CF4</b>  | Driver's seat Comfort, belt in seat   |
| <input checked="" type="checkbox"/> <b>ESP-BAS1</b>           | ESP for tractor combinations with ABS/EBS or rigid vehicles/combinations with std center of gravity  | <input type="checkbox"/> <b>DST-CF5</b>             | Driver's seat Comfort, belt in seat, heated, adjustable lumbar&side support, extendable seat cushion  |
| <input type="checkbox"/> <b>ESPC-RO</b>                       | Electronic stability program functionality control, switch - On/Reduced/Off  | <input type="checkbox"/> <b>DST-CF6</b>             | Driver's seat Comfort, belt in seat, heated, ventilated   |
| <input type="checkbox"/> <b>HWSS-ACB</b>                      | Adaptive cruise control with forward collision warning (stationary and moving objects) and emergency braking. Using both radar and camera to collect info. | <input type="checkbox"/> <b>DST-LUX1</b>            | Driver's seat Deluxe, belt in seat, heated, ventilated  |
| <input type="checkbox"/> <b>HWSS-FCB</b>                      | Collision Warning with Emergency Brake (forward)   | <input type="checkbox"/> <b>DST-LUX2</b>            | Driver's seat Deluxe, belt in seat, heated  |
| <input type="checkbox"/> <b>LSS-DW</b>                        | Lane Keeping Support - lane departure warning  | <input type="checkbox"/> <b>SBD-RED</b>             | Red safety belts, passenger and driver seats  |
| <input type="checkbox"/> <b>LSS-DW3</b>                       | Pilot Assist - active, continuous lane keeping   | <input type="checkbox"/> <b>SBPRE-DS</b>            | Driver's seat belt pretensioner   |
| <input type="checkbox"/> <b>LCS2</b>                          | Side Collision Avoidance Support, passenger side collision warning (sound and visual information), passenger side  | <input type="checkbox"/> <b>PST-BAS1</b>            | Passenger seat Basic, non-suspended   |
| <input type="checkbox"/> <b>LCS3</b>                          | Active Side Collision Avoidance Support, Collision Warning (sound and visual information) with Emergency Brake, passenger side                             | <input checked="" type="checkbox"/> <b>PST-CF4</b>  | Passenger seat Comfort, suspended, belt in seat   |
| <input type="checkbox"/> <b>LCS5</b>                          | Active Side Collision Avoidance Support: Collision Warning for both sides (sound and visual information) and Emergency Brake for passenger side            | <input type="checkbox"/> <b>PST-CF5</b>             | Passenger seat Comfort, suspended, belt in seat, electrically heated  |
| <input type="checkbox"/> <b>DAS-W</b>                         | Driver Alert Support   | <input type="checkbox"/> <b>PST-RX1</b>             | Passenger seat Relax, swivel, tilt  |
| <input type="checkbox"/> <b>RSENS-W</b>                       | Wipers rain sensor   | <input type="checkbox"/> <b>PST-STD2</b>            | Passenger seat Regular, non-suspended   |
| <input type="checkbox"/> <b>CU-ECC</b>                        | Automatic climate control with sun sensor  | <input type="checkbox"/> <b>PST-STD4</b>            | Passenger seat Regular, suspended   |
| <input checked="" type="checkbox"/> <b>Standard Equipment</b> |  | <input type="checkbox"/> <b>SBPRE-PS</b>            | Passenger seat belt pretensioner  |
| <input type="checkbox"/> <b>Optional Equipment</b>            |  | <input type="checkbox"/> <b>ARMRE-BB</b>            | Two armrests on both driver's and passenger seats   |
|   |  | <input type="checkbox"/> <b>ARMRE-DB</b>            | Two armrests on driver's seat   |
|   |  | <input type="checkbox"/> <b>ARMRE-PB</b>            | Two armrests on passenger seat  |
|   |  | <input type="checkbox"/> <b>ARU-BAS</b>             | Vinyl armrest upholstery  |
|   |  | <input type="checkbox"/> <b>ARU-LEA</b>             | Leather armrest upholstery  |
|   |  | <input checked="" type="checkbox"/> <b>GRABHI-B</b> | Instep grab handle, basic   |
|   |  | <input type="checkbox"/> <b>GRABHI-L</b>            | Leather covered steel instep grab handle  |

For more detailed information about cab and powertrain equipment, please refer to separate specification sheets.

For all possible options and combinations of options please consult your Volvo sales contact who can create a specification to match your requirements using the Volvo Sales Support system (VSS).

The factory reserves the right to modify design and change equipment without previous notification. The specification can vary from country to country.

# MODEL RANGE

FH D13 64 Rigid Diesel Rear Air FH 64R 3A

- **FMAT-RUB** Black rubber floor mats
  - **FMAT-TX2** Two textile (dark grey on FH/FM/FMX, black on FH16) and two black rubber floor mats
  - **LBK80F** Lower fixed bed 2000x815/740/660 mm (middle/head/feet), foldable 55°, safety net included
  - **LBK80FRE** Lower electric recliner bed 2000x815/740/660 mm (mid/head/feet), foldable 55°, safety net included
  - **LBK80FRM** Lower manual recliner bed 2000x815/740/660 mm (mid/head/feet), foldable 55°, safety net included
  - **MATL-FI** Mattress lower bed firm, pocket springs, recommended for body weight over 100 kg
  - **MATL-FI4** Mattress lower bed firm, foam, recommended for body weight up to 100 kg
  - **MATL-SF** Mattress lower bed semi-firm, pocket springs, recommended for body weight up to 100 kg
  - **OLMAT-BA** Overlay mattress, 28 mm thick black textile
  - **OLMAT-PR** Overlay mattress Premium, 35 mm thick black textile
  - **TBK60AD** Height adjustable top bed 600x1900 mm, foldable up to 52° (dep. on cab & upper storage), net incl.
  - **TBK60F** Fixed top bed 600x1900 mm, foldable up to 52° (depending on cab & upper storage), net included
  - **TBK70AD** Height adjustable top bed 700x1900 mm, foldable up to 52° (dep. on cab & upper storage), net incl.
  - **TBK70F** Fixed top bed 700x1900 mm, foldable up to 52° (depending on cab & upper storage), net included
  - **PH-CAB2** Cab parking heater, 2 kW
  - **PH-ENGCA** Engine and cab parking heater
  - **CPC-ADV** I-Park Cool, electric parking cooler, integrated with AC system
  - **SLCP-BAS** Basic sleeper control panel (interior light, parking heater, roof hatch, door locks)
  - **SLCP-LUX** Luxury sleeper control panel (int. light, park heat/cool, hatch, locks, alarm clock, windows, audio)
  - **SAFE** Key-operated safety box under bed (FH) or at bed end (FM)
  - **RUS-BAS** Storage in rear upper cab, 154 litres (300 mm high)
  - **RUS-HIG** Storage in rear upper cab, 245 litres (440 mm high)
  - **TABLE** Foldable and height-adjustable table, attaches to the lower bed
  - **REFR-RUS** Refrigerator 28-litre, with dividers, on rear upper wall
  - **REFRIG** Refrigerator 33-litre, with freezer and dividers, in drawer under bed
  - **MICRO-PK** Preparation kit for microwave oven (electrical cables to front shelf)
  - **BOTH-D** One bottle holder under dashboard centre section
  - **BOTH-DL** Two bottle holders: one under dashboard centre section, one on lower bed drawer
  - **BOTH-L** One bottle holder on lower bed drawer
  - **COFMA-PK** Preparation kit (24 V) for coffee maker
  - **SOL12S** 12 V single outlet in sleep compartment
  - **INLI-BAS** Interior white light with smooth light transition at on/off, no dimming
  - **INLI-NL** Interior white and red (night) light with smooth light transition at on/off
  - **INLI-NLD** Interior white and red (night) light with smooth light transition at on/off and dimmer
  - **ARL-FLEX** Two (driver and passenger side) LED reading lamps with flexible arms, mounted on sidewalls
  - **RH-EE** Roof skylight/emergency exit, tinted glass (not a hatch)
  - **RH-ER** Roof hatch, electrically operated, steel, with emergency exit handle
  - **RH-ETR** Roof hatch, electrically operated, tinted glass, rear opening 50 mm
  - **RH-MTR** Roof hatch, manually operated, tinted glass, rear opening 50 mm
  - **GLAS-TIN** Tinted windows
  - **GLAS-UNT** Untinted windows
  - **SWIND-BS** Rear side window on both sides
  - **VANMIR** Vanity mirror in front shelf lid
  - **AS-FUS** One extra shelf in each of the two front upper storage compartments
  - **INFOT-PK** Preparation kit (bracket, security straps, and antenna cable) for mounting of TV above driver door
- ### Cab exterior
- **EXTL-BAS** Exterior trim level basic
  - **EXTL-EN2** Exterior trim level enhanced 2
  - **EXTL-ENH** Exterior trim level enhanced
  - **DGLAS-H** Tempered door window glass
  - **DGLAS-L** Laminated window glass in doors. The glass can crack, but retains its protective effect. It also provides better sound insulation.
  - **BUMP-B** Plastic front bumper
  - **BUMP-B2** Steel front bumper
  - **BUMP-HD** Heavy-duty front bumper
  - **BUMP-SP** Front bumper spoiler
  - **AUXFS** Extra footstep in cab side
  - **GUARD-EH** Guard plate for cooling pipes and oil sump
  - **BUGNET** Insect screen (PVC-coated fibreglass) in front of radiator
  - **CTILT-P-E** Electric cab tilt pump
  - **FCABS-A** Air front cab suspension
  - **FCABS-M** Mechanical front cab suspension
  - **RCABS-A** Air rear cab suspension
  - **RCABS-M** Mechanical rear cab suspension
  - **HCC-EXT** Unlockable front lid - Exterior hood catch control
  - **HCC-INEX** Electrically operated front hatch, improves vehicle security by preventing unauthorised people from gaining access to vital areas behind the hatch. The security lock is fitted on the cab wall and has a cylinder that locks the front. It is switched on and
  - **MIRCFPCS** Rear-view and wide-angle mirrors (both sides), passenger corner camera (FM, FH)
  - **MIRCMCP** Camera Monitor System and passenger corner camera
  - **MIRCMS** Camera Monitor System
  - **MIRCOMF** Rear-view and wide-angle mirrors (both sides), kerb observation mirror
  - **AMIR-F20** Front close-view mirror above windscreen, passenger side (radius 200 mm)
  - **AMIR-FCR** Front and corner close-view mirror, passenger side (radius 200 mm)
  - **SUNV-H** Exterior front sun visor, transparent dark-grey
  - **AD-ROOF** Roof air deflector
  - **AD-SIDES** Cab side air deflectors, short
  - **HL-BASIC** Halogen H7 headlamps
  - **HL-LED** LED headlamps
  - **HL-LED3** LED headlamps with adaptive high beam
  - **HL-CLEAN** High-pressure headlamp cleaner
  - **HLP-ST** Steel headlamp protectors (steel and plastic for FMX)
  - **HL-ADJ** Manually adjustable headlamp beam
  - **DRL-LED** Daytime running lamps (LED)
  - **UDRL** Without daytime running lamps (LED)
  - **DRIVL2** Extra main beam
  - **UDRIVL** Without extra main beam
  - **FOGL-WC** White front fog lamps
  - **CL-STAT** Static cornering lights
  - **ASL-RF2** Two LED spot lamps in sign box

■ Standard Equipment      □ Optional Equipment

For more detailed information about cab and powertrain equipment, please refer to separate specification sheets.

For all possible options and combinations of options please consult your Volvo sales contact who can create a specification to match your requirements using the Volvo Sales Support system (VSS).

The factory reserves the right to modify design and change equipment without previous notification. The specification can vary from country to country.

# MODEL RANGE

## FH D13 64 Rigid Diesel Rear Air FH 64R 3A

|   |  |   |   |
|---|--|---|---|
| <input type="checkbox"/> <b>IDLAMP-A</b>            | Three amber identification lamps on mid front roof   | <input checked="" type="checkbox"/> <b>ECBB-HIG</b> | Body builder electrical centre, body builder module with 14 high and 4 low digital outlets  |
| <input type="checkbox"/> <b>IDLAMP-W</b>            | Three white identification lamps on mid front roof   | <input type="checkbox"/> <b>ECBB-MED</b>            | Body builder electrical centre, body builder module with 7 high and 4 low digital outlets   |
| <input type="checkbox"/> <b>IDLMPSW</b>             | Switch in cab for identification lamps   | <input type="checkbox"/> <b>BBCHAS1</b>             | One 7-pole bodywork connector on chassis  |
| <input type="checkbox"/> <b>BEACOA2F</b>            | Two amber LED beacons on cab front roof  | <input type="checkbox"/> <b>BBCHAS3</b>             | Three 7-pole bodywork connectors on chassis   |
| <input type="checkbox"/> <b>BEACOA2R</b>            | Two amber LED beacons on cab rear roof   | <input type="checkbox"/> <b>BEPR-T2</b>             | Bodywork electrical and software preparation for tipper with remote control   |
| <input type="checkbox"/> <b>BEACON-P</b>            | Preparation kit for roof beacons   | <input type="checkbox"/> <b>EXSTER</b>              | Support for external steering control via body builder module   |
| <input type="checkbox"/> <b>BEACONA4</b>            | Four amber LED beacons on roof - two on front, two on rear   | <input checked="" type="checkbox"/> <b>TD-LED</b>   | TD-LED detects trailers that have either bulb lights or LED lights. Continuous monitoring of the trailer connection status allows optimization of gear shifting and systems like Electronic Stability Program (ESP). Full diagnostics are available for bulb lights, while for LED lights the system cannot identify an "open circuit". |
| <input type="checkbox"/> <b>CABPT-R1</b>            | One front cab roof pass-through on passenger side  | <input type="checkbox"/> <b>FRFS-BS</b>             | Frame rail free space on both sides to give space for crane legs or other equipment   |
| <input type="checkbox"/> <b>CABPT-R2</b>            | Two front cab roof pass-throughs, one on each side   | <input type="checkbox"/> <b>FBA-BTF</b>             | Front body attachment brackets, lower, for flexible body  |
| <input type="checkbox"/> <b>SPOTP-F</b>             | Preparation kit for spot lamp in cab front, max 280 W  | <input type="checkbox"/> <b>FBA-BTSP</b>            | Front body attachment brackets, lower, for semi-flexible body   |
| <input type="checkbox"/> <b>SPOTP-R</b>             | Preparation kit for spot lamp in cab roof, max 280 W   | <input checked="" type="checkbox"/> <b>HBA-FSFB</b> | Holes for body attachments, flexible/semi-flexible body   |
| <input type="checkbox"/> <b>SPOTP-RF</b>            | Preparation kit for spot lamp in cab roof and front, max 280 W                                       | <input type="checkbox"/> <b>HBA-SB</b>              | Holes for body attachments, stiff body  |
| <input type="checkbox"/> <b>ROS-IL</b>              | Roof sign illumination   | <input type="checkbox"/> <b>RBA-T2</b>              | Rear body attachment brackets, lower  |
| <input type="checkbox"/> <b>ROS-IL2</b>             | Preparation kit for installation of roof sign illumination   | <input type="checkbox"/> <b>CRANEPK1</b>            | Frame-mounted crane interface plates, up to 10 tonne-metres   |
| <input type="checkbox"/> <b>ROS-ILP</b>             | Wiring kit for roof sign illumination  | <input type="checkbox"/> <b>CRANEPK2</b>            | Frame-mounted crane interface plates, up to 20 tonne-metres   |
| <input type="checkbox"/> <b>CSGN-GTR</b>            | Globetrotter decal in the roof sign box  | <input type="checkbox"/> <b>CRANEPK4</b>            | Frame-mounted crane interface plates, up to 40 tonne-metres   |
| <input checked="" type="checkbox"/> <b>HORN-F1S</b> | Single-tone Jericho horn behind grille, operated by steering wheel buttons                           | <input type="checkbox"/> <b>AUXL-SPK</b>            | Preparation kit (wiring and a switch in dashboard) for snow plough lamps  |
| <input type="checkbox"/> <b>HORN-R2S</b>            | Two chromed single-tone air horns on the roof, operated by steering wheel buttons                    | <input type="checkbox"/> <b>TAILPRE2</b>            | Tail lift preparation kit, wireless remote operation  |
| <input type="checkbox"/> <b>ANT-CBR</b>             | Preparation kit for communication/CB radio: roof-mounted single antenna and wiring                   | <input type="checkbox"/> <b>TAILPREP</b>            | Tail lift preparation kit   |
| <input type="checkbox"/> <b>ACCBR-AP</b>            | Accessory brackets mounted on front roof, midroof and rear roof                                      | <input type="checkbox"/> <b>AESW2</b>               | 2 bistable bodywork switches (marked AUX1/AUX2)   |
| <input type="checkbox"/> <b>ACCBR-F</b>             | Accessory bracket mounted on front roof  | <input type="checkbox"/> <b>AESW2PK</b>             | 2 bistable bodywork switches (marked AUX1/AUX2) + prepared for 4 bistable switches (dummy switches)   |
| <input type="checkbox"/> <b>ACCBR-FM</b>            | Accessory brackets mounted on front roof and midroof   | <input checked="" type="checkbox"/> <b>AUXSW-4</b>  | Hardwiring for 4 extra switches (from body builder electrical centre to instrument panel)   |
| <input type="checkbox"/> <b>ACCBR-FR</b>            | Accessory brackets mounted on front and rear roof  | <b>Services</b>                                     |   |
| <input type="checkbox"/> <b>ACCBR-M</b>             | Accessory bracket mounted on midroof   | <input checked="" type="checkbox"/> <b>TGW-4GWL</b> | Telematics gateway with 4G modem and WLAN   |
| <input type="checkbox"/> <b>ACCBR-R</b>             | Accessory brackets mounted on mid-roof and rear roof   | <input type="checkbox"/> <b>TGW-PK</b>              | Telematics gateway preparation kit  |
| <input type="checkbox"/> <b>ACCBR-RM</b>            | Accessory bracket mounted on rear roof   | <input checked="" type="checkbox"/> <b>FMS-PK</b>   | Fleet management system gateway, preparation kit  |
| <input type="checkbox"/> <b>STUC-B</b>              | Extra storage compartment under cab, on both sides   | <input type="checkbox"/> <b>TSRS2</b>               | Road sign recognition (not ISA compliant)   |
| <input type="checkbox"/> <b>STUC-L</b>              | Extra storage compartment under cab, on left side  |   |   |
| <input type="checkbox"/> <b>STUC-R</b>              | Extra storage compartment under cab, on right side   |   |   |
| <b>Superstructure preparations</b>                  |  |   |   |
| <input type="checkbox"/> <b>SW782-ME</b>            | Swap body with front stop block for wheelbase 4900 mm, body lengths 7150/7450/7820 mm, height 130 mm |   |   |
| <input type="checkbox"/> <b>SW782-OE</b>            | Swap body with front stop block for wheelbase 4900 mm, body lengths 7150/7450/7820 mm, height 190 mm |   |   |
| <input type="checkbox"/> <b>CROSSRE</b>             | Cross reinforcement of frame for swap body   |   |   |
| <input type="checkbox"/> <b>SRWL-2RW</b>            | 2 white LED reverse/work lamps, rear-facing on rear chassis, 3-pos switch (On/Off/Reverse auto On)   |   |   |
| <input type="checkbox"/> <b>SRWL-PK</b>             | Preparation kit for LED reverse/work lamps at rear chassis, 3-pos switch (On/Off/Reverse auto On)    |   |   |
| <input type="checkbox"/> <b>SWL-2FW</b>             | 2 white LED work lamps at front of chassis, and a 2-position switch (On/Off)                         |   |   |
| <input type="checkbox"/> <b>SWL-2RW</b>             | 2 white LED work lamps, rearward-facing on rear chassis (LH/RH side)                                 |   |   |
| <input type="checkbox"/> <b>SWL-4W</b>              | 4 white LED work lamps on chassis (2 front, 2 rear) and a flexible switch (On/Off)                   |   |   |
| <input type="checkbox"/> <b>SWL-PK</b>              | Preparation kit for LED work lamps on chassis, with a 2-pos switch (On/Off)                          |   |   |
| <input type="checkbox"/> <b>WL-CHPK</b>             | Preparation kit for work lamp (switch with cable to frame, by gearbox)                               |   |   |
| <input type="checkbox"/> <b>WLC-H2A</b>             |  |   |   |
| <input type="checkbox"/> <b>WLC-H2W</b>             | 2 white LED work lamps, high-mounted on back of cab (switch included)                                |   |   |
| <input type="checkbox"/> <b>WLC-PKCH</b>            | Preparation kit (cables and switch) for work lamp inside or outside superstructure                   |   |   |
| <input type="checkbox"/> <b>WLC-PKH</b>             | Preparation kit (cables and switch) for high-mounted work lamps on back of cab                       |   |   |
| <input type="checkbox"/> <b>WLC-PKL</b>             | Preparation kit (cables and switch) for low-mounted work lamps on back of cab                        |   |   |
| <input type="checkbox"/> <b>WLC-PKLH</b>            | Preparation kit (cables and switch) for low- and high-mounted work lamps on back of cab              |   |   |
| <input type="checkbox"/> <b>ECBB-BAS</b>            | Body builder electrical centre, prepared for body builder module                                     |   |   |

Standard Equipment

Optional Equipment

For more detailed information about cab and powertrain equipment, please refer to separate specification sheets.

For all possible options and combinations of options please consult your Volvo sales contact who can create a specification to match your requirements using the Volvo Sales Support system (VSS).

The factory reserves the right to modify design and change equipment without previous notification. The specification can vary from country to country.

# MODEL RANGE

FH D13 64 Rigid Diesel Rear Air FH 64R 3A

---

Volvo Trucks. Driving Progress