

MODEL RANGE

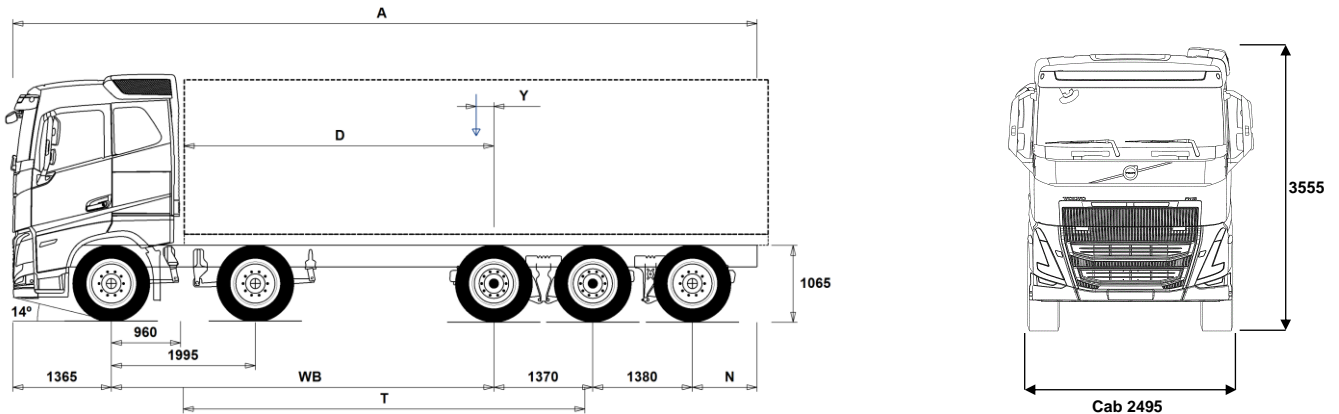

Volvo Trucks. Driving Progress

NEW FH 16 10x4 Rigid - Tag Tridem - N3 – contact sales engineering reference



Chassis Dimensions [mm]

WB Wheelbase	4300	4350	4600	4900	5100	5600	6000
A Overall Chassis Length	9660	9710	9960	10260	10460	10960	11360
D Center of rear axle to front of body	3290	3340	3590	3890	4090	4590	4990
N Rear Overhang (Min.)	895	895	895	895	895	895	895
N Rear Overhang (Max.)	1245	1245	1245	1245	1245	1245	1245
T Theoretical Wheelbase	4561	4611	4861	5161	5361	5861	6261
Y Center of Gravity for Payload (Min.)	-1185	-1183	-1171	-1157	-1150	-1128	-1113
Y Center of Gravity for Payload (Max.)	568	590	702	837	925	1147	1324

Chassis Weights [kg]

Front Axles	7650	7645	7610	7580	7570	7530	7510
Rear Bogie	3540	3555	3620	3710	3760	3855	3940
Kerb Weight	11190	11200	11230	11290	11330	11385	11450
Payload (including body, driver, fuel, etc.)	20810	20800	20770	20710	20670	20615	20550

Turning Diameter [mm]

Turning Circle Diameter Kerb to Kerb	18100	18200	19000	20000	20600	22200	23500
Turning Circle Diameter Wall to Wall	19400	19500	20300	21300	22000	23600	24800

Plated Weights [kg]

	Plated	Design
Gross Vehicle Weight	32000	43000
Gross Combination Weight	44000	44000
Front Axles	16000	16000
Rear Bogie	24000	27000

Important Notes

Chassis Dimensions

Cab Height: +305 mm for CAB-HSLP, -283 mm for CAB-LSLP, +450 mm for CAB-XHSL.

D-measure includes a front clearance of 50 mm and for rigid trucks also a subframe of 100 mm.

Height can vary ± 20 mm for leaf and ± 10 mm for air suspension.

All dimensions are for unladen chassis and any tag axles down. Chassis height used: CHH-HIGH.

Rear overhang used for vehicle weight calculation is the maximum rear overhang (N Max.) for selected wheelbase.

Height change when chassis height CHH-MED,FRAME300: 0 mm.

Weight and dimensions are based upon the following tyres:

Front Axle Tyres:	315/80R22.5
Drive Axle Tyres:	315/80R22.5
Trailing/Pusher Axle Tyres:	315/80R22.5

Chassis weight includes oil, water, AdBlue, 0 litres fuel and without driver. Kerb weight can vary $\pm 3\%$.

Turning diameters are theoretically calculated. Tag axle used: TA-HYDRS.

Legal weights can differ from country to country.

For more detailed weight information, including optional equipment weights, ask your Volvo sales contact to enter your specification into the Volvo Weight Information system (WIS).

Do NOT use this drawing for bodybuilding. Refer to Volvo Bodybuilder Instructions and chassis assembly drawing FH104RFT6A.

MODEL RANGE

NEW FH 16 10x4 Rigid - Tag Tridem - N3 – contact sales engineering reference

TRUCK USE

- **RC-ROUGH** Road conditions - On / off-road
- **RC-SMOOTH** Road Conditions - Smooth
- **TIPP-PRE** Transport Adaption - Tipper vehicle preparation
- **UNIFORM** Transport Adaption - Basic platform vehicle

CORE COMPONENTS

- **CHH-HIGH** Chassis Height - High - for loading heights check the unique BEP chassis drawing
- **CHH-MED** Chassis Height - Medium - for loading heights check the unique BEP chassis drawing
- **CHH-XHIGH** Chassis Height - X-High - for loading heights check the unique BEP chassis drawing
- **RADDT-G2** Rear air suspension - 3 axles - 2 driven/1 tag, high ground clearance
- **RADDT-GR** Rear air suspension - 3 axles - 2 driven / 1 tag
- **FH16HSL5** Globetrotter cab - all steel safety cage design with roof mounted emergency escape hatch. Designed and built to Swedish impact and ECE R29 regulations
- **FH16LSL5** Low Sleeper Cab
- **FH16SLP5** Cab - Sleeper - all-steel safety cage design with roof-mounted emergency escape hatch. Designed and built to Swedish impact and ECE R29 regulations
- **FH16XHS5** Globetrotter XL cab - all steel safety cage design with roof mounted emergency escape hatch. Designed and built to Swedish impact and ECE R29 regulations
- **EU6DS** Euro 6 SCR, particulate filter, EGR and dual stage turbo
- **D16K550** Engine - D16K550 16 litre developing 550hp at 1550-1900rpm SCR & EGR. Peak torque 2900Nm at 900-1350rpm. 2800Nm at 900-1400rpm with manual gearbox
- **D16K650** Engine - D16K650 16 litre developing 650hp at 1450-1900rpm SCR & EGR. Peak torque 3150Nm at 950-1450rpm.
- **D16K750** Engine - D16K750 16 litre developing 750hp at 1600-1800rpm SCR & EGR. Peak torque 3550Nm at 950-1400rpm.
- **EBR-EPG** Engine Brake Type - Exhaust brake controlled by steering column switch
- **EBR-VEB+** Engine Brake Type - Volvo engine brake + and exhaust pressure governor, enhanced performance from additional exhaust rocker control. Retardation 375kW
- **AT2812F** Gearbox - AT2812E 12-speed "I-shift" automated mechanical suitable for gross train weights up to 60 tonne. Refer to sales engineering when used in conjunction with a PTO
- **ATO3112F** Gearbox - ATO3112F 12-speed "I-shift" overdrive automated mechanical, suitable for gross train weights up to 60tonne. Refer to sales engineering when used in conjunction with a PTO
- **ATO3512F** ATO3512F 12-speed "I-shift" automated mechanical, suitable for gross train weights up to 60 tonne. Refer to sales engineering when used in conjunction with a PTO
- **ASO-C** Crawler gear - Ratio direct top gearbox 19:1 Ratio Overdrive gearbox 17:1
- **ASO-ULC** Ultra low crawler and crawler gear - Ratios direct top gearbox 32:1 and 19:1 Ratios Overdrive box 32:1 and 17:1
- **RTH2610F** Drive Axles - RTH2610F 26-tonne hub reduction tandem with differential and cross locks* - design GCW 100tonne * Cross locks replaced by a dog clutch if tandem axle lift is specified.
- **RTS2310A** Drive Axles - RTS2310A 23-tonne single reduction tandem with differential and cross locks*- design GCW 100tonne * Cross locks replaced by a dog clutch if tandem axle lift is specified

■ Standard Equipment

□ Optional Equipment

For more detailed information about cab and powertrain equipment, please refer to separate specification sheets.

For all possible options and combinations of options please consult your Volvo sales contact who can create a specification to match your requirements using the Volvo Sales Support system (VSS).

The factory reserves the right to modify design and change equipment without previous notification. The specification can vary from country to country.

- **RTS2370A** Drive Axles - RTS2370A 23-tonne single reduction tandem with differential and cross locks*- design GCW 70tonne * Cross locks replaced by a dog clutch if tandem axle lift is specified

PACKAGES

- **FUELPACK** Long Haul Fuel Economy driving package
- **DRIVE16** Drive + Package
- **1LIVING** Sleep & Resting Package - Living one-bed
- **1LIVING+** Sleep & Resting Package - Living one-bed +
- **2LIVING** Sleep & Resting Package - Living two-bed
- **2LIVING+** Sleep & Resting Package - Living two-bed +
- **INFOBAS** Basic media package without secondary display
- **INFODF** Media Information Platform with Dynafleet Support
- **INFOMED** Media Information Platform - Medium level
- **INFONAV** Media Information Platform with Navigation
- **INFONDF** Media Information Platform with Navigation & Dynafleet Support
- **VISI5** Visibility Package
- **VISI5+** Visibility plus Package
- **VISI5++** Visibility ++ Package
- **VISIC5** Visibility Package
- **VISIC5+** Visibility plus Package
- **SAFE-VE** Active Safety Package
- **SAFE-VE+** Active Safety + Package
- **CHASPAC** Chassis Package Rigid

CHASSIS

- **FST-AIR** Front suspension type - Air
- **FST-PAR** Front suspension type - 2 leaf parabolic springs
- **FST-PAR3** Front suspension type - 3 leaf parabolic springs
- **FSL5-BAS** Front suspension levelling - basic stroke
- **FAL16.0** Front axle design capacity - 16 tonnes - 2 x 8 tonne front axles
- **FAL18.0** Front axle design capacity - 18 tonnes - 2 x 9 tonne front axles - check tyre load index
- **FAL20.0** Front axle design capacity - 20 tonnes - 2 x 10 tonne front axles - check tyre load index
- **FSM-LUB** Front suspension maintenance - Lubricated rear shackles on pins and bushings
- **FSTAB** Front anti-roll bar - Normal stiffness
- **FSTAB2** Front anti-roll bar - Medium stiffness
- **FSTAB3** Front anti-roll bar - High stiffness
- **RAL27** Rear bogie design capacity - 27 tonne
- **RAL33** Rear bogie design capacity - 33 tonne
- **RAL36** Rear Bogie Design Capacity - 36 tonne
- **RALIM105** Rear-axle load limiter - 10.5 tonne - speed controlled
- **RALIM115** Rear-axle load limiter -11.5 tonne - speed controlled
- **RALIM13** Rear-axle load limiter - 13 tonne
- **RALIM95** Rear-axle load limiter - 9.5 tonne
- **ASF-DL1** Air suspension with 1 driving level
- **ASF-DL3** Air suspension with 3 driving levels
- **ACTST-TO** Active Steering- Volvo Dynamic Steering - VDS - with extra electronic pump and torque overlay
- **ASFE-BAS** Active steering feature - Basic - Volvo Dynamic Steering - VDS - only
- **ASFE-OG** Active steering feature - Volvo Dynamic Steering - VDS - with stability assist - oversteer
- **ASFE-PO** Active steering feature - Volvo Dynamic Steering - VDS - with personal settings and stability assist
- **ASFE-PS** Active steering feature - Volvo Dynamic Steering - VDS - with personal settings
- **PSP-VAR** Power steering pump - Variable displacement
- **EBS-MED** Brake package - EBS medium including "hill" hold function
- **AUXPARK** Auxiliary parking brake - Additional spring brakes

MODEL RANGE

NEW FH 16 10x4 Rigid - Tag Tridem - N3 – contact sales engineering reference

■ FRAME300	Chassis frame section external height - 300 mm	□ C-RO50	Rockinger RO 50 50mm for centre axle trailer
■ FST8080	Chassis frame thickness - 8 mm web and flange	□ C-VBG750	VBG 750 coupling (centre axle trailer) Contact VBG on 01925 234111 to validate the coupling rating for the application
■ FIL-EEEB	Chassis frame inner liner - From the end of the engine to the end of the bogie	□ TOWR-ONE	Towing hitch attached to rear crossmember
□ FIL-EEEF	Chassis frame inner liner - From the end of the engine to end of the frame	□ TREL-PK	Trailer electrical preparation kit - chassis/cab wiring
□ 2BAT210B	Battery Capacity - 2 x 210 Ah - Gel type	□ TREL14	Single 14 pole electrical trailer connector
■ 2BAT210C	Battery Capacity - 2 x 210 Ah - AGM Absorbent Glass-fibre Material type	□ TREL15	Trailer electrical connection - Single 15 pin - ADR certified
■ BATTAMP	Battery management - Voltage and current gauge	□ TREL7	7 pole - 24N trailer electrical suzie
□ BATTIND	Battery management - Charge indicator	□ TREL7-7	Trailer electrical connection - 2 x 7 pin - 24N and 24S
□ ADR2	ADR Adaptation - For transportation of dangerous goods on the road - Note does NOT include safe loading pass package if required this is quoted separately	□ TBC-DUO	Duomatic type air line connectors
□ MSWI-A	Battery master switch - ADR switch circuit shut down	□ TBC-EC	Trailer brakes with EC palm coupling connectors
■ MSWI-C	Battery master switch - Chassis mounted toggle by the battery box	□ TRBR-HCF	Full pressure hand controlled trailer brake
□ MSWI-R	Battery master switch - Key fob operated remote controlled	□ TRBR-STA	Stationary trailer brake control
■ UR-FUEL	Without right-hand fuel tank Min volume 255l Max volume 810l	□ TRB-STRE	Stretch Brake - Automatic low speed trailer brake activation to avoid jack-knifing and improve steerability
■ UL-FUEL	Without left fuel tank Min volume 160l Max volume 450l	□ FFEND-B	Standard mounted mud wings on second front axle
□ ADTP-L	AdBlue tank position - Chassis mounted on the left-hand side	□ FFEND-T	Transport mounted mud wings on second front axle
■ ADTP-R	AdBlue tank position - Chassis mounted on the right-hand side	□ RFEND-B	Three piece EC approved rear mud wings and spray flaps
□ ADB032	Plastic AdBlue tank - 32 litres	□ RFEND-T	Rear mud wings - Temporary on drive axle for transport delivery only
□ ADB048	Plastic AdBlue tank - 48 litre	□ RFH-BAS	Basic rear wing height
□ ADB064	Plastic AdBlue tank - 64 litre	□ RFH-HIG	High rear wing height - higher wing tops
□ ADTC-BF	AdBlue tank cover with satin alloy look decorative cover	□ RFH-LOW	Lower rear wing height - shallower wing tops
■ FCAP-L	Diesel and AdBlue filler cap - Locking	□ ATANK-AL	Air tanks - Aluminium
■ FUFF-AS	Fuel filler - Anti-spill device	■ ATANK-ST	Air tanks - Steel
□ FUFF-ATS	Fuel filler - Anti-spill & anti-syphon device	□ TL-LED	Rear lights - LED
□ ESH-LEFT	Exhaust - Horizontal silencer - left outlet	■ BLIGHT-E	Emergency brake light
■ ESH-REAR	Exhaust - Horizontal silencer - rear outlet		
□ ESH-RIGH	Exhaust - Horizontal silencer - right outlet		
□ ESH-VERT	Exhaust - Horizontal silencer - vertical outlet		
□ EXST-SSP	Stainless steel exhaust stack - NOT polished		
□ EXST-ST	Steel exhaust stack		
□ WHC-FIX2	Wheel chocks - Two fixed design		
□ WHC-FOL2	Two foldable wheel chocks		
□ WHCP-F	Wheel chock carrier position - In the front part of the vehicle		
□ WHCP-R	Wheel chock carrier position - In the rear part of the vehicle		
□ WHCP-T	Wheel chock carrier position - Outer luggage locker		
□ TB-L80	Toolbox 800 mm, left side		
□ TB-R80	Toolbox 800 mm, right side		
□ SUP-BAS	EC approved chassis side guards		
□ CHAIN-S	Snow chains		
□ HOOK-SC	Snow chain hooks		
■ TOWF-NO1	Front towing device - One detachable - stored in cab		
□ TOWF-NO2	Front towing device - Two detachable - stored in cab		
□ TOWMBRH	Towing member, high mounted in centre of frame, D = 150		
□ TOWMBRL1	Towing member, low mounted under the frame		
□ TOWMBRM	Towing member, medium mounted in line with frame lower flange		
■ RFEC-S	Rear frame profile - Straight cut		
□ RFEC-U	Rear frame profile - Slight uppercut for tipper		
□ C-RI4040	Towing coupling, Ringfeder 4040 G-150		
□ C-RI5055	Towing coupling, Ringfeder 5055 G-150		
□ C-RO400G	Towing coupling, Rockinger 400 G-150 for 40mm eyes		

■ Standard Equipment

□ Optional Equipment

For more detailed information about cab and powertrain equipment, please refer to separate specification sheets.

For all possible options and combinations of options please consult your Volvo sales contact who can create a specification to match your requirements using the Volvo Sales Support system (VSS).

The factory reserves the right to modify design and change equipment without previous notification. The specification can vary from country to country.

MODEL RANGE

NEW FH 16 10x4 Rigid - Tag Tridem - N3 – contact sales engineering reference

- AVO-ENH** I-Shift application software - for construction and off road applications
- APF-ENH** I-shift enhanced PTO functions
- TC-MAOH2** Extra high performance transmission oil cooler - air to oil with front mounted radiator
- TC-MWO** Basic transmission oil cooler - water to oil
- 2COM1100** Air compressor - Two-cylinder 1100 litres per minute
- 2COMP900** Air compressor - Two-cylinder 900 litres per minute
- CLU-AIRC** Clutchable air compressor
- AIRIN-FR** Front air intake fitted to the underside of cab engine tunnel
- AIRIN-HI** Air intake - Roof-mounted behind cab on the left-hand side
- AIRIN-LO** Low level air intake behind cab on left hand side
- ACL1ST-S** Air filter - two-stage element
- 24AL120B** Alternator capacity - 120 amp alternator
- 24AL150B** Alternator capacity - 150 amp
- CCV-C** Closed crankcase engine ventilation
- CCV-OX** Closed crankcase ventilation for cold markets
- PRIM-EL** Electrical priming pump
- AF-R** Hot fuel recirculation heated fuel filter
- FUEFE2SW** Small engine mounted dual fuel filter with water separator
- EST-AID** Engine starting aid -Preheating element in the air inlet manifold
- 220EBH15** 220V/1.5Kw electric engine block heater
- PTER-DIN** Engine power-take-off - Rear-mounted with DIN5462 (female) splined shaft for a close-coupled pump
Models with 3 steering axles will use this to drive the steering pump (AUXPSP)
- HPE-V45** Parker VP1-45, variable displacement, single flow, engine mounted hydraulic pump
- HPE-V75** Parker VP1-75, variable displacement, single flow, engine mounted hydraulic pump
- PTR-D** Gearbox PTO for plug-in pump, 0.71xeng speed
- PTR-DH** Gearbox driven high speed PTO for one plug-in hydraulic pump
- PTR-DM** Gearbox driven medium speed PTO for one plug-in hydraulic pump
- PTR-F** Gearbox driven PTO with rear flange connection
- PTRD-D** Gearbox driven HIGH SPEED PTO for two plug-in hydraulic pumps
- PTRD-F** PTO with 1 DIN + 1 flange connection rear, manual gearbox
- HPG-F101** Parker F1-101 gearbox mounted, fixed displacement, single flow, hydraulic pump
- HPG-F41** Parker F1-41 gearbox mounted, fixed displacement, single flow, hydraulic pump
- HPG-F51** Parker F1-51 gearbox mounted, fixed displacement, single flow, hydraulic pump
- HPG-F61** Parker F1-61 gearbox mounted, fixed displacement, single flow, hydraulic pump
- HPG-F81** Parker F1-81 gearbox mounted, fixed displacement, single flow, hydraulic pump
- STWPOS-R** Steering wheel position - RIGHT-HAND DRIVE
- STWM-LE** Leather steering wheel
- STGW-AD2** Adjustable steering wheel with neck tilt
- STGW-ADJ** Adjustable steering wheel
- AIRBAG** SRS Driver's air bag
- INST-BAS** Basic level instruments
- DRC-AMII** DPF Regeneration control switch - for manual and switching off regeneration
- 1DAYDIG2** Tachograph - Continental VDO 4.0
- ARSL** Additional road speed limit - switch in dashboard
- ESP-BAS1** Electronic Stability Control
- ESPC-RO** ESP (Electronic Stability Program) functionality control - Reduced / Off
- HWSS-ACB** Adaptive cruise control ACC with forward collision warning and AEBS advanced emergency brake system
- HWSS-FCB** Forward collision warning with AEBS advanced emergency brake system
- LSS-DW** Lane departure-warning system
- LCS** Lane change support
- DAS-W** Driver Alert Support system
- RSENS-W** Rain sensing windscreen wipers
- CU-ECC** Cab Climate Unit - Electrically controlled air conditioning with sun sensor
- CU-ECC2** Cab Climate Unit - Electrically controlled air conditioning with a carbon filter, sun, mist, and air quality sensor
- IMMOBIL** Thatcham H2 approved immobiliser
- ALARM-E** Enhanced vehicle alarm - Thatcham H1 approved - Cab plus external sensor for body/trailer
- ALCOLOCK** Alcolock
- AMPL400** Radio amplifier, 8 channel, 400 W with subwoofer
Located in right hand external storage box
- BUPMON** Back up monitor - Digital reverse camera, parameter & lead supplied loose in cab.
- PHONE-PK** Telephone preparation kit (antenna, antenna attachm. cable incl.)
- ISUNS-BS** Side sun visor - Driver & passenger side
- ISUNS-DS** Side sun visor - Driver-side
- ISUNF-RE** Electrically operated textile interior sun blind
- ISUNF-RM** Manually operated textile interior sun blind
- CSPL-BX** Lower center dash open storage box
- CSPL-BXD** Lower centre dash drawer
- CSPU-SDR** One open storage and one drawer - behind push open lid - in upper part of the centre dash panel
- CSPU-SS** Two open storages - behind push open lid in upper part of the centre dash panel
- ADFS** Two extra DIN slots in front shelf - can be fitted with card or drawer available as an accessory
- BUPALARM** Reverse alarm
- RTOLL-PK** Road toll PREPARATION kit for trucks operating with "Toll Collect" in Germany
- LOADIND** Load indicator with central dashboard display
- REMC-MF** Multi-functio wireless remote control
- FIREXT3S** Fire extinguisher - 3kg mounted on the seat base
- WARNVEST** High visibility warning vest - no sleeves
- AIDKIT** First aid kit - Legal demand for EU markets including delivery to EU bodybuilder
- AIDKIT1B** First aid kit - Legal demand for trucks transiting Germany
- WARNLAMP** Portable warning lamp
- LAMP-IN** Inspection lamp
- BULBKIT** Bulb and fuse kit
- WRITEPAD** Writing pad
- DST-CF4** Driver seat - Suspended, adjustable shock absorber, travel, backrest & lumbar controls - seatbelt mounted to the seat
- DST-CF5** Driver seat - Suspended with adjustable shock absorber, travel, backrest, lumbar & heat controls - seatbelt mounted to the seat
- DST-CF6** Driver seat - Suspended with adjustable shock absorber, travel, backrest, lumbar, heat and ventilation controls - seatbelt mounted to the seat

■ Standard Equipment

□ Optional Equipment

For more detailed information about cab and powertrain equipment, please refer to separate specification sheets.

For all possible options and combinations of options please consult your Volvo sales contact who can create a specification to match your requirements using the Volvo Sales Support system (VSS).

The factory reserves the right to modify design and change equipment without previous notification.
The specification can vary from country to country.

MODEL RANGE

NEW FH 16 10x4 Rigid - Tag Tridem - N3 – contact sales engineering reference

- DST-LUX1** Driver seat - Deluxe 1: electrical adjustment with memory function, lumbar support, heating & ventilation - seatbelt mounted to the seat
- DST-LUX2** Driver seat - Deluxe 2: electrical adjustment with memory function, lumbar support & heating - seatbelt mounted to the seat
- SBD-RED** Seat belt colour - Red
- SBPRE-DS** Driver seat belt pretensioner
- PST-BAS1** Passenger seat - Fixed non suspended fold up with seatbelt mounted in cab
- PST-CF4** Passenger seat - Suspended, adjustable shock absorber, travel, backrest & lumbar controls - seatbelt mounted to the seat
- PST-CF5** Passenger seat - Suspended with adjustable shock absorber, travel, backrest, lumbar & heat controls - seatbelt mounted to the seat
- PST-RX1** Passenger seat - Fixed non suspended, features: 90-degree rotation and tilt function with seatbelt mounted in cab
- PST-STD2** Passenger seat - Fixed with backrest adjustment, non suspended with seatbelt mounted in cab
- PST-STD4** Passenger seat - Standard suspended with seatbelt mounted in cab
- SBPRE-PS** Passenger seat belt pretensioner
- ARMRE-BB** Armrests - Two on both driver & passenger seats
- ARU-LEA** Armrest upholstery - Leather
- GRABHI-B** Steel instep cab grab handle
- GRABHI-L** Leather covered instep cab grab handle
- FMAT-RUB** Footwell floor mats - Rubber
- FMAT-TX2** Footwell floor mats - Two sets, Rubber and textile with an embossed pile supplied in the cab
- LBK80F** Lower fixed bunk with wide middle section 815 in the centre x 2000 mm
- LBK80FRE** Lower electrically operated recline bunk with wide middle section 815 in the centre x 2000 mm
- LBK80FRM** Lower manually operated recline bunk with wide middle section 815 in the centre x 2000 mm
- MATL-FI** Firm lower bunk pocket sprung mattress
- MATL-FI4** Lower mattress - firm, memory foam, 2000x700x130 mm
- MATL-SF** Lower flexizone mattress - semi-firm, pocket springs up to 100kg - 16 stone
- OLMAT-BA** 35mm mattress overlay protector
- OLMAT-PR** 50mm premium mattress overlay protector
- TBK60AD** Height adjustable foldable top bunk 600 x 1900mm
- TBK60F** Fixed foldable top bunk 600 x 1900mm
- TBK70AD** Height adjustable foldable top bunk 700 x 1900mm
- TBK70F** Fixed foldable top bunk 700 x 1900mm
- PH-CAB2** 1.8kW Air to air night heater
- PH-ENGCA** Engine and cab night heater
- SLCP-BAS** Sleeper control panel - Basic with switches for interior light, night heater, roof hatch and door lock
- SLCP-LUX** Sleeper control panel - Luxury with switches for interior light, night heater, roof hatch, door lock, alarm clock, window and radio
- SAFE** Safe box for driver's personal items
- RUS-BAS** Rear cab upper storage - 300 mm high
- RUS-HIG** Rear cab upper storage - 440 mm high - volume 245 litres
- TABLE** Folding and height adjustable table - on lower bunk
- REFR-RUS** Fridge - 28 litre rear upper wall mounted with dividers
- REFRIG** Fridge - 33 litre under-bunk mounted with freezer dividers
- MICRO-PK** Wiring preparation kit for microwave oven
- BOTH-D** One bottle holder under dashboard centre section
- BOTH-DL** Two bottle holders, one under dashboard centre section and one mounted to the under bunk drawer
- BOTH-L** One bottle holder mounted to the under bunk drawer
- COFMA-PK** Coffee maker, preparation kit.
- INLI-BAS** Interior white LED lights - basic
- INLI-NL** Interior white and red night LED light with no dimmer
- INLI-NLD** Interior white and red night LED light with dimmer
- ARL-FLEX** Two flexible reading lamps (snake lamps)
- RH-EE** Fixed tinted glass sky window with emergency exit
- RH-ER** Steel roof hatch - Electrically operated, rear opening with emergency exit
- RH-ETR** Tinted glass roof hatch - Electrically operated, rear opening with emergency exit
- RH-MTR** Tinted glass roof hatch - Manually operated, rear opening with emergency exit
- GLAS-TIN** Tinted windows.
- SWIND-BS** Extra side window on both sides behind "B" pillar
- VANMIR** Vanity mirror in front shelf
- AS-FUS** Extra shelf in front upper storage compartments
- INFOT-PK** Preparation kit for the mounting of a flat screen TV in cab above the driver's door, includes bracket, electrical and speaker connections

CAB EXTERIOR

- EXTL-BAS** Basic exterior finish - Satin Volvo badges, grey grille, instep, bumper, bumper spoiler, grille, door handles mirror housing and sunvisor if specified.
- EXTL-EN3** Enhanced exterior finish - Waterfall Grille. Chrome Volvo badges and door handles. Instep, bumper and bumper spoiler in cab colour if specified. Aluminium step inserts. Mirror housing and sun visor if specified with silver accents.
- DGLAS-H** Tempered door glass
- DGLAS-L** Laminated door glass
- LOCK-REM** Door locks - Remote central locking
- BUMP-B** Plastic front bumper
- BUMP-B2** Steel front bumper
- BUMP-HD** Heavy duty front bumper
- BUMP-SP** Front bumper spoiler
- AUXFS** Lower swinging cab step
- GUARD-EH** Engine guard to protect sump and engine hoses
- BUGNET** Insect screen in front of radiator
- CTILT-P-E** Electrically operated hydraulic cab tilt
- CTILT-P-M** Manually operated hydraulic cab tilt
- FCABS-A** Front cab suspension - Air
- FCABS-M** Front cab suspension - Mechanical spring
- RCABS-A** Rear cab suspension - Air
- RCABS-M** Rear cab suspension - Mechanical spring
- HCC-EXT** Exterior hood catch control
- HCC-INEX** Exterior and interior hood catch control
- MIRCFPCS** Mirrors - Electrically heated and operated main and wide-angle with manually adjusted kerb view mirror on the passenger side and position camera in nearside mirror arm.
- MIRCOMF** Electrically heated and operated main and wide angle mirrors and manually adjusted kerb view mirror on passenger side
- MIRSTD** Electrically heated main and wide angle mirrors and manually adjusted kerb view mirror on passenger side
- AMIR-F20** Auxiliary front view mirror with a 200mm radius
- SUNV-H** External smoke grey sunvisor
- AD-ROOF** Roof air deflector
- AD-SIDES** Short cab side air deflector for rigid bodywork
- HL-BASIC** Halogen H7 head lamps
- HL-CLEAN** Head lamp cleaner - washer jets

Standard Equipment

Optional Equipment

For more detailed information about cab and powertrain equipment, please refer to separate specification sheets.

For all possible options and combinations of options please consult your Volvo sales contact who can create a specification to match your requirements using the Volvo Sales Support system (VSS).

The factory reserves the right to modify design and change equipment without previous notification. The specification can vary from country to country.

MODEL RANGE

NEW FH 16 10x4 Rigid - Tag Tridem - N3 – contact sales engineering reference

- **HLP-ST** Headlamp protection
- **HL-ADJ** Headlight adjustment - Switch in cab
- **DRIVL2** Two spot lamps
- **UDRIVL** Without auxiliary driving lights
- **FOGL-WC** Front fog lights
- **CL-STAT** Static corner lights
- **ASL-RF2** Two Hella H11 70W spotlamps in sign box - only available with the basic headlight and no lower driving lights.
- **BEACOA2F** Roof beacons - Two front roof mounted amber LED
- **BEACOA2R** Roof beacons - Two rear roof mounted amber LED
- **BEACON-P** Roof beacons - wiring preparation only
- **BEACONA4** Roof beacons - Four amber LED - two front/ two rear
- **CABPT-R1** Single outlet for roof mounted accessories
- **CABPT-R2** Twin outlets for roof mounted accessories.
- **SPOTP-F** Spotlamp preparation in front, max 280W
- **SPOTP-R** Spotlamp preparation on roof, max 280W
- **SPOTP-RF** Spotlamp preparation on cab roof and in cab front, max 2x280W
- **ROS-IL2** Preparation kit for illuminated roof sign with switch loose in cab, fit after registration
- **ROS-ILP** Roof sign illumination preparation kit
- **CSGN-ENG** Engine size and power headboard logo
- **CSGN-GTR** "Globetrotter" headboard logo
- **HORN-F1S** Horn - Air single tone - chassis mounted
- **HORN-R2S** Horn - Air - Two roof-mounted
- **ANT-CBR** Roof mounted antenna for CB radio, single aerial
- **ACCB-R-AP** Front, middle & rear roof mounted accessory brackets
- **ACCB-R-F** Front roof mounted accessory bracket
- **ACCB-R-FM** Front & middle roof mounted accessory brackets
- **ACCB-R-FR** Front & rear roof mounted accessory brackets
- **ACCB-R-M** Middle roof mounted accessory bracket
- **ACCB-R-R** Rear roof mounted accessory bracket
- **ACCB-R-RM** Rear & middle roof mounted accessory brackets
- **STUC-B** Left and right storage compartments under cab
- **STUC-L** Left storage compartment under cab
- **STUC-R** Right storage compartment under cab
- **REFS-TW** White cab conspicuity markings by packed in cab
- **REFS-TY** Yellow cab conspicuity markings by packed in cab
- **BEPR-T2** Body builder electrical software preparation for tipper with remote control
- **EXSTER** External steering control - Volvo dynamic steering and bodybuilder module prepared for external control system, installed and computer by bodybuilder
- **TD-BAS** Trailer detection WITHOUT LED sensing
- **TD-LED** Trailer detection with LED sensing
- **FRFS-BS** Frame rail free space on both sides to give space for crane legs or other equipment.
- **FBA-BTF** Lower front body attachments for torsionally flexible - platform body
- **FBA-BTSF** Lower front body attachments for torsionally semi-flexible body - box or curtainsider
- **HBA-FSFB** Holes for body attachments - flexible/semi-flexible body
- **HBA-SB** Holes for body attachments - stiff body
- **RBA-T2** Lower rear body attachments for helper frame
- **CRANEPK1** Crane plates mounted to frame, for cranes up to 10 tonne metre capacity
- **CRANEPK2** Crane plates mounted to frame, for cranes up to 20 tonne metre capacity
- **CRANEPK4** Crane plates mounted to frame, for cranes up to 40 tonne metre capacity
- **AUXL-SPK** Electrical preparation kit - wiring and switch for snow plough lights
- **TAILPRE2** Tail lift preparation kit, wireless remote operation
- **TAILPREP** Taillift preparation kit - cab switch and warning in driver display
- **AESW2** Two Body builder bistable electrical switches (marked AUX1 / AUX2)
- **AESW2PK** 2 Body builder bistable el.switches (marked AUX1/AUX2) and prep. for 4 more switches
- **AUXSW-4** Wiring for 4 extra switches (from Body builder electrical centre to switch positions)

DELIVERY SERVICES

- **TGW-4GWL** Telematics gateway - GSM/GPRS/4G modem, LTE & WLAN
- **FMS-PK** Fleet Management System gateway
- **DRUT2** Driver utility app - "My Truck" - two-year subscription
For mobile phone, tablet, with android and IOS systems.
Only available with Volvo Connect subscription

SUPERSTRUCTURE PREPARATIONS

- **SRWL-PK** Chassis-mounted working lamps - Side work and reverse lamp preparation and 3 position switch - Max load 280W
- **SWL-2FW** Chassis-mounted working lamps - Two white front-mounted LED lamps
- **SWL-2RW** Chassis-mounted working lamps - Two white rear-mounted LED lamps
- **SWL-4W** Chassis-mounted working lamps - Four white front and rear-mounted LED lamps
- **SWL-PK** Chassis-mounted working lamps - Side work lamp preparation and 2 position switch - Max load 280W
- **WLC-H2A** Two H3/70W working lamps with amber coloured lens high mounted back of cab
- **WLC-H2W** Two H3/70W white working lamps high mounted on the back of cab
- **WLC-PKCH** Working lamp back of cab - Preparation kit - cables and switch
- **WLC-PKH** Preparation kit, cables and switch for high mounted working lamps back of cab
- **WLC-PKL** Preparation kit, cables and switch for low mounted working lamps back of cab
- **WLC-PKLH** Preparation kit - cables and switch for low and high mounted working lamps back of cab.
- **ECBB-HIG** Body builder electrical centre with body builder module
- **BBCHAS1** One 7-pole connector for Body builder interface
- **BBCHAS3** Three 7-pole connectors for Body builder interface

VOLVO

Volvo Truck Corporation
volvotrucks.com