

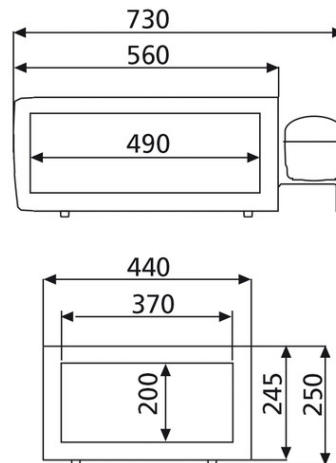

FACT SHEET

Refrigerator PCA80106



The compressor unit is placed behind the refrigerator.

30 litre refrigerator in drawer under bunk (FM)

A spacious and extensible drawer fridge with volume of 30 litres is available for all FM and FMX sleeper cabs.

The drawer fridge is centrally positioned under the bed which make it easy accessible for both driver and passenger. It has convenient handling with unlocking and opening in one movement.

Temperature regulation is done with a continuously variable thermostat. The fridge is CFC free (ChloroFluoroCarbon compounds) and is E-certified (EMC/vehicle directive).

The fridge front is in black and the bunk panels are in Raven Black.

To give space to the drawer the bed is mounted approximately 250 mm higher than in an ordinary FM cab. Due to the raised bunk position the specified mattress is replaced by a unique 125 mm thick pocket spring mattress (comfort level firm MATL-FI and level Semi Firm MATL-SF) with cut outs (116x627 mm +116x501 mm) for the seats.

The whole mattress has two different firmness (MATL-FI / MATL-SF.) No cut outs for overlay mattress protector, if any specified. Distance from top of engine tunnel to top of bed is approx. 480 mm. Distance between top of bed to storage compartment over bed is approx. 840 mm in cab FM-HSLP/ FMX-HSLP and approx. 970 mm in cab FM-XHSL.



FEATURES AND BENEFITS

- Convenient access with easy-pull drawer running on roller bearing slides.
- The fridge is CFC free.
- Whole vehicle type approved (WVTA).

SPECIFICATION

Volume	30 litres
Temperature area	+12 °C to -2 °C
Medium power consumption	40 W
Dimensions (WxHxD)	440 mm x 250 mm x 730 mm (inclusive compressor unit)
Weight	48 kg

Note! This option might add some necessary variants to the truck specification which can affect the price of the truck. For specific information, please check in the VSS-system under functionality "Show Variant Combination".

Note! This code in combination with armrests on seats may cause damage to the inner armrest when seat is in backward position and armrest is in upward position. The armrests might hit the bottom plate of the bed when accidentally excessive force is put on them.



Volvo Truck Corporation

volvotrucks.com

Volvo retains the right to modify design and specifications without prior notification.