



**EBS-STD is an electronically controlled anti-lock disc-brake system in basic configuration. The system considerably increases driving safety and driveability.**

EBS is an extremely fast-acting system thanks to its electronic signal transmission. By adjusting braking force at the wheels and axles to suit the vehicle's weight distribution, EBS achieves braking with optimal characteristics.

The system precisely adjusts its responses by analysing the vehicle's current operating situation. This is done with a number of sensors that register parameters such as wheel speed, braking force and brake function.

The braking system is designed to suit both single- and combination vehicles.

EBS has a pneumatic backup system consisting of two independent braking circuits similar to a conventional braking system. They step in to provide good braking performance if the EBS system stops functioning for any reason.

## CUSTOMER BENEFITS

- Fast-acting system that decreases the braking distance.
- Brake-force distribution enhances stability and counteracts jack-knifing tendencies.
- Less wear on wheel brakes with Brake Blending function.
- Greater safety with emergency brake assistance.

### Fast-acting system that cuts the stopping distance

EBS is integrated into the vehicle's own electronic architecture. The EBS control unit uses a number of electrical signals to determine brake pressure in each individual brake cylinder. This electronic control is instantaneous and gives a balanced braking performance.

When the driver presses the brake pedal, signals specifying the required brake pressure are sent to the control unit. From a number of sensors, the control unit also receives information about parameters such as wheel speed, braking power and brake function. Based on this information, brake pressure is then regulated individually for each axle and wheel.

### Brake-force distribution enhances stability and counteracts jack-knifing tendencies

In order to avoid instability and jack-knifing tendencies braking force is distributed according to the principle that each axle should brake its own axle weight, and every part of the vehicle rig should brake its own weight.

### Less wear on the wheel brakes with Brake Blending function

With the Brake Blending function activated, the auxiliary brakes are applied together with the wheel brakes when the brake pedal is pressed. This reduces wheel brake wear. Braking force is adjusted to suit the vehicle's weight and brake pedal pressure.

### Greater safety with emergency brake assistance

If the driver brakes suddenly, EBS notes this and increases braking pressure to provide the most effective braking and the shortest stopping distance possible.

### Broad function programme for enhanced traffic safety and productivity

The following systems are included in the EBS-STD program pack:

**ABS** – Anti-lock Braking System.

**Brake blending** – the auxiliary brakes are activated and support the wheel brakes.

**Poor brake performance warning** – alerts the driver if retardation is too low in relation to pedal pressure.

**Brake temperature warning** – monitors brakes temperature.

**Differential Lock Synchro (DLS)** – the driven wheels are synchronised prior to engagement of the differential lock.

**EBS status recorder** via the TEA Truck Electronic Architecture and VCADS Pro (Volvo Computer Aided Diagnostics System).

**External Brake Demand (EBD)** via other systems.

**Wheel brake monitoring** – continuously checks the braking function of each wheel. A fault code is stored in the diagnostic system.

**Drag torque control** prevents the driven wheels from locking up on slippery road surfaces when the accelerator is released.

**Emergency brake assistance** allows full braking force to be reached more quickly in emergency situations.

For tractors there is also:

**Automatic brake compensation (CFC – Coupling Force Control)** between the tractor and trailer.

**Trailer brake** – makes it possible to carry out a safety check when switching trailers. Only for the Volvo FE.

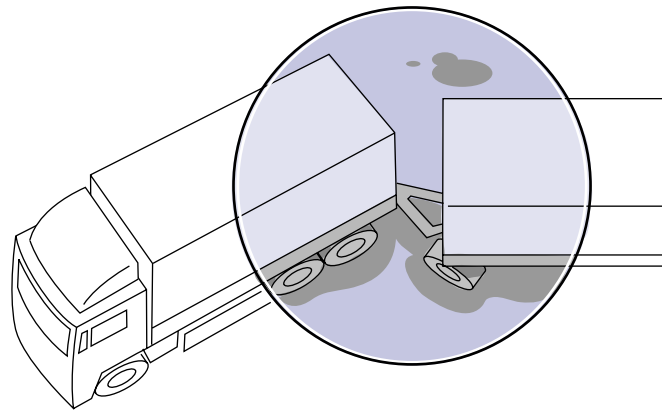

In order to avoid instability and jack-knifing tendencies braking force is distributed according to the principle that each axle should retard its own axle weight, and every part of the vehicle rig should retard its own weight.